

TWIN DISC
INCORPORATED



Service Manual

Marine Transmission

Model:
MG-507A

Document Number: 1015835

NOTICE

Twin Disc, Incorporated makes no warranty or guaranty of any kind, expressed, implied or otherwise, with regard to the information contained within this manual. Twin Disc, Incorporated has developed this manual through research and testing of the information contained therein. Twin Disc, Incorporated assumes no responsibility for any errors that may appear in this manual and shall not be liable under any circumstances for incidental, consequential or punitive damages in connection with, or arising out of, the use of this manual.

Table of Contents

Section I	INTRODUCTION	5
Section II	DESCRIPTION	6
Section III	PRINCIPLES OF OPERATION	12
Section IV	HYDRAULIC SYSTEM	16
Section V	PREVENTIVE MAINTENANCE	20
Section VI	TROUBLE SHOOTING	22
Section VII	OIL SEAL REPLACEMENT	25
Section VIII	REMOVAL	25
Section IX	DISASSEMBLY	26
Section X	CLEANING AND INSPECTION	34
Section XI	ASSEMBLY	35
Section XII	INSTALLATION	46
Section XIII	SPECIAL TOOLS	48
Section XIV	PARTS LISTS	55
Section XV	ACCESSORIES AND OPTIONAL EQUIPMENT	66

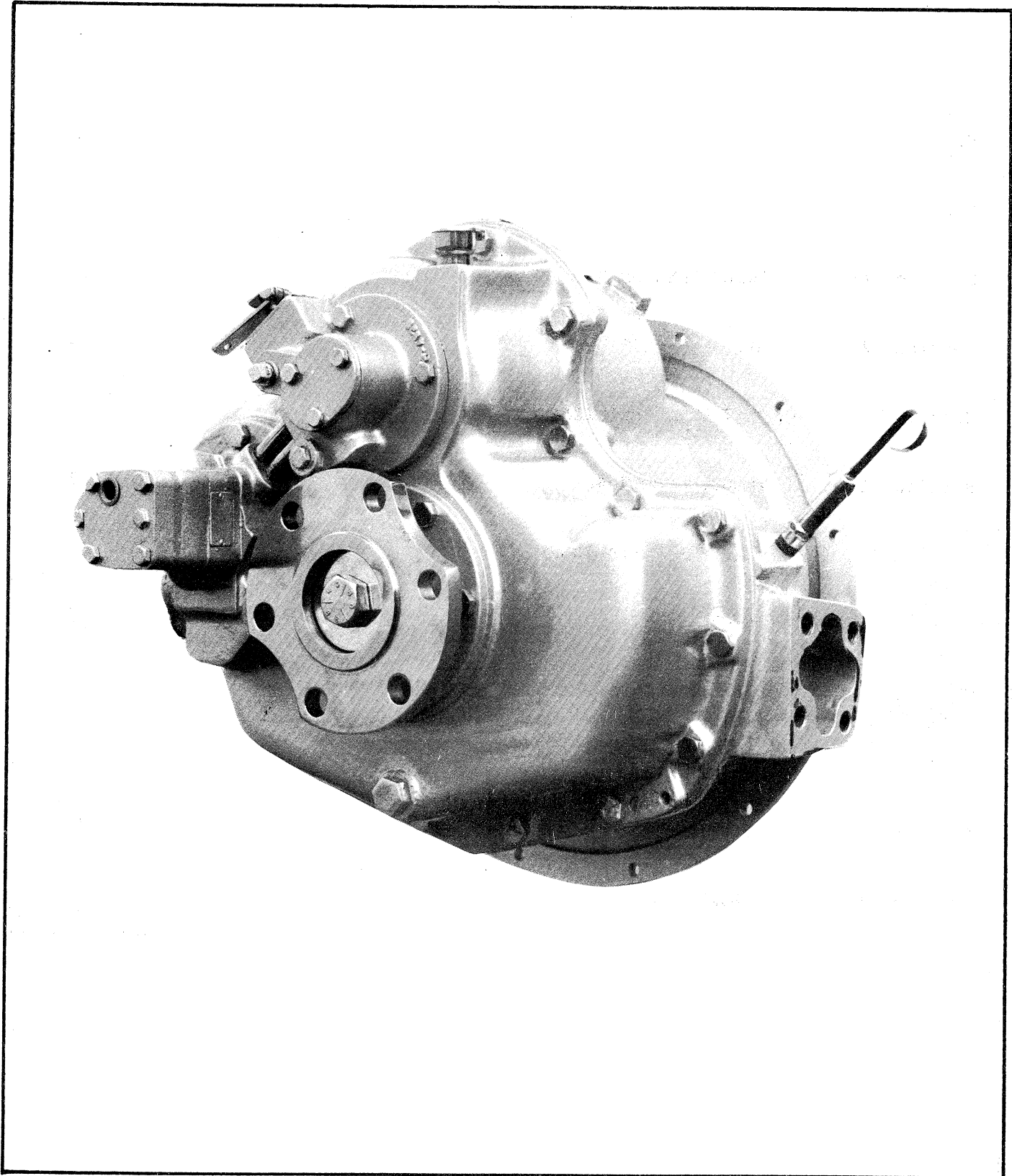

Figure 1. Model MG-507-A Marine Transmission — Rear view.

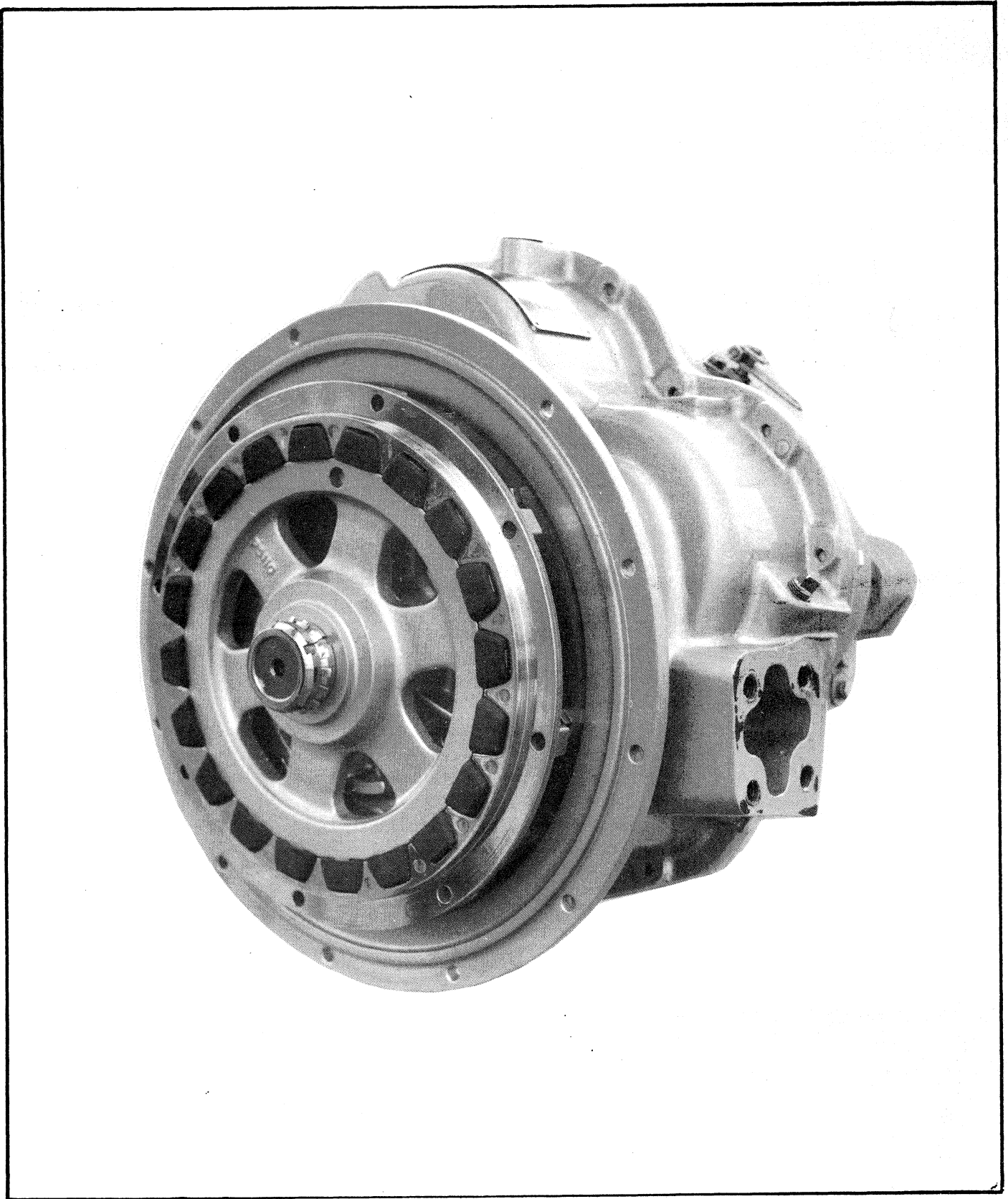

Figure 2. Model MG-507-A Marine Transmission — Front view.



Section I. INTRODUCTION

1. GENERAL.

This maintenance manual is designed to provide instructions for the operation, removal, disassembly, assembly and installation of the Twin Disc Model MG-507-A Marine Transmission. Engineering details and the performance characteristics of marine transmissions can be obtained from the Marine Application Department of Twin Disc. (For address, see fly leaf).

In addition, this manual includes engineering drawings for the fabrication of Special Tools that will assist disassembly and assembly procedures; a complete parts breakdown, with exploded view illustrations, and parts lists to facilitate ordering replacement parts; a trouble-shooting chart to help determine, and solve functional difficulties that may occur; and operating specifications, aids to installation and other pertinent data to comprehensively cover all aspects of the operation/maintenance of this equipment.

2. DISTRIBUTION.

It is recommended that this maintenance manual be made available to, and read by, all personnel responsible for the operation or maintenance of the marine transmission. A thorough understanding of the material in this manual will result in increased life and satisfactory service from the marine transmission.

3. ORDERING PARTS.

A. Source. Renewal Parts, Service Parts Kits can be obtained from Twin Disc or from any Twin Disc distributorship. Locate your nearest current parts source by writing to Twin Disc. (For address, see fly leaf).

B. Method. When ordering a spare or replacement part, always give the figure number of the illustration containing the part, the item number of the part, the description of the part, and the quantity required. Do not use the word "complete", but state each item required. Do not designate the quantity by "sets", but specify the number of parts needed. *The Model, Specification, and Serial Number of the unit must be included as part of the order.* These numbers will always be found stamped on the marine transmission instruction plate.

NOTE

If detail part numbers of the marine transmission are desired, write to an address given in Paragraph 3 A, and submit the specification number of the unit.

4. PARTS SHIPMENT.

A. Method. Whenever ordering spare or replacement parts, state specifically whether the parts are to be shipped by freight, express, etc. If shipping instructions are not specified on the order, we will use our own judgement, considering time as well as expense. Twin Disc will NOT be responsible for any charges incurred by this procedure.

B. Destination. Furnish the complete shipping destination and postal address. All parts shipments made from the factory will be F.O.B.

5. REPLACEMENTS AND ADJUSTMENTS.

A. General. Any complaint which the user or ultimate customer may have concerning the marine transmission must be submitted through the original equipment manufacturer or the dealer from whom the unit was purchased.

B. Warranty Conditions. Twin Disc, having stipulated the specification number on the marine transmission instruction plate, absolves itself of any responsibility resulting from any external, internal or installation changes made in the field without the express written approval of Twin Disc. All returned parts new or old resulting from any of the above stated changes will not be accepted for credit. Furthermore, any marine transmission which has been subjected to such changes will not be covered by the Twin Disc, Standard Warranty.



Section II. DESCRIPTION

6. MARINE TRANSMISSION

A. The Twin Disc Models MG-507-A Marine Transmission 70° down angle configuration described in this manual is righthand rotation, (when viewed from the front of the engine) for installation on a right-hand engine.

NEVER USE THESE MARINE TRANSMISSION WITH A LEFT-HAND ROTATION ENGINE.

The Marine Transmission consists of four major subassemblies : the forward clutch group of parts, the reverse clutch group of parts, the input group of parts, and the output group of parts. The selector valve assembly is externally-mounted on the rear of the unit over the forward clutch location. The selector valve assembly is the control device that hydraulically engages the desired clutch. A 4.33 gpm at 2000 rpm oil pump assembly is externally-mounted at the rear of the unit over the reverse clutch location. The oil pump assembly supplies oil under pressure to the selector valve assembly through the pump mount for clutch engagement, clutch cooling, and bearing and gear lubrication. The oil is strained and filtered (when filter used) before entering the marine transmission hydraulic system. The MG-507-A Marine Transmission are flange-type units that are bolted directly to the engine flywheel housing. The driving ring furnished with the transmission is installed on the engine flywheel. The standard driving ring is designed to mesh with the rubber blocks installed on the drive spider which is installed on the input shaft. This method of drive is used because of the comparative ease of removal and installation; however, care must be exercised during installation to ensure that proper alignment between the marine transmission and the engine is attained. An optional driving ring and drive spider is also available.

The designation "Forward and Reverse" clutch assembly does not necessarily mean, that the boat propulsion direction agrees. In marine transmission engineering terms, the "Forward" clutch assembly, when engaged, means the drive from input to output

is through the least number of gears. The "Reverse" clutch, when engaged directs the drive through the greatest number of gears from input to output. In the models MG-507-A the forward clutch drive train includes four gears; the reverse clutch drive train includes five gears.

B. **Reduction Ratios.** The following overall reduction ratios are available with the model MG - 507A Marine Transmission described in this maintenance manual : 1,101 : 1; 1,50 : 1; 1,1.98 : 1; 2.54 : 1; 2.99 : 1.

C. **Optional Equipment.** The accessories described below are available from Twin Disc for the MG - 507-A Marine Transmission except the hose and heat exchanger kit.

(1) **Companion Flange.**

(2) **Hose-and-Heat Exchanger Kit.** The heat exchanger should be mounted in a location convenient to both engine water and marine transmission oil. A heat exchanger *must be used* with the marine transmission. It is also advisable to install an oil pressure gauge with a range of 0 to 300 psi between the heat exchanger and the oil inlet entry port of the selector valve assembly.

(3) **Oil Filter Assembly.** Twin Disc recommends that an oil filter assembly be installed in the hydraulic system between the heat exchanger and the selector valve assembly. The oil filter assembly should have sufficient capacity for oil pressures to 400 psi with a flow rate of 6 gpm. A replaceable 25 micron (minimum) element should be contained in the oil filter assembly. Contact Twin Disc for further information.

(4) **Pressure Rate of Rise.** Valve with or without TROLLING VALVE. This option can only be purchased with the unit and will therefore not be available as Kit. When a pressure rate of rise valve is used, an oil filter must be fitted.

7. INPUT GROUP OF PARTS.

A. Driving Ring. The driving ring is a high-quality aluminum casting that is bolted to the engine flywheel. The ring has internal gear teeth that mesh with the rubber blocks installed on the drive spider.

B. Drive Spider. The drive spider, with rubber blocks installed, is the connecting member between the driving ring on the engine flywheel and the marine transmission. (External lugs are machined on the drive spider for rubber block installation). The drive spider is on the tapered input shaft.

C. Rubber Blocks. The rubber blocks, molded in an involute tooth shape, are installed on the external lugs of the drive spider. Misalignment caused by hull distortion is absorbed by the cushioning effect of the rubber blocks; however, extreme care must be observed during marine transmission installation to achieve the dial indicator tolerances specified in the section on installation. The rubber blocks also tend to absorb torsional vibrations which may be present.

D. Input Gear Shaft. The protruding end of the input gear shaft is tapered for the installation of the drive spider. Tapered roller bearings are mounted on the shaft on both sides of the input gear. One bearing cup is installed in the bearing support, and the other bearing cup is installed in a web of the main housing.

E. Input Gear. The input gear is made in one piece with the input shaft and located between tapered roller bearings. The input gear turns in engine direction, and is in constant mesh with the forward clutch housing gear.

8. FORWARD AND REVERSE CLUTCH GROUP OF PARTS.

A. General. The forward clutch group of parts and the reverse clutch group of parts are identical in construction and parts, except for the width of the clutch housing gears. Therefore, the following description will apply to both the forward and reverse clutch groups of parts.

B. Clutch Shaft. The clutch shaft is made of steel, and contains two horizontally-drilled passages that are intersected by cross-drilled holes. One passage supplies oil pressure for clutch engagement, and the other passage supplies oil pressure for clutch cooling and lubrication of moving parts. A solid ball plug is

installed at the rear end of the clutch engagement passage in the clutch shaft to contain the oil. An orifice is drilled at the front end of the cooling and lubrication passage in the clutch shaft to permit a metered flow of oil to return to lubricate the front tapered bearings. A slot milled in the rear end of the clutch shaft is used to drive the oil pump assembly. A tapered roller bearing installed on each end of the clutch shaft (and in the main housing) supports the clutch shaft, and therefore the clutch pack, in the marine transmission. Ring shaped grooves are machined in the clutch shaft for a snap ring and two piston rings. Two piston rings are installed in the grooves at the rear end of the clutch shaft to direct oil to the proper passage. An external snap ring used to retain the return spring, is installed in the groove of the clutch shaft at approximately the mid-point of the shaft.

C. Clutch Housing Gear. The clutch housing gear is installed on the clutch shaft adjacent to the front tapered roller bearing and contains the clutch pack. The forward clutch housing gear is in constant mesh with the input gear and the reverse clutch housing gear. The external teeth of the back plate and the seven sintered-metal clutch plates are aligned with the internal teeth of the clutch housing gear. Three cross-drilled holes in the clutch housing gear permit the cooling and lubricating oil to return to sump. A hole is provided in the clutch housing to locate the anti-rotation pin. A dump valve is located in the face of the clutch housing gear to avoid the pressure to build up by centrifugal effect when clutch is not engaged.

D. Clutch Pack. The clutch pack is contained within the clutch housing gear, and consists of the clutch piston, a pin, the clutch piston spring, seven sintered-metal clutch plates, six steel clutch plates, the back plate, the clutch hub pinion assembly and two needle thrust bearings. The clutch housing gear is bored internally to contain the clutch piston. A hole is provided in both the clutch housing gear and the clutch piston to fit a pin which will eliminate relative rotation between these two parts. The O'ring installed in the clutch piston seals the inside diameter of the clutch piston and the lathe cut ring installed on the outer periphery of the clutch piston seals the outside diameter of the clutch piston. The clutch piston spring is positioned around the clutch shaft between the clutch piston, a steel washer and the external snap ring installed in the clutch shaft. The clutch hub pinion assembly is installed on the clutch shaft between the thrust bearings and the cone of the rear tapered roller bearing. Two thrust needle bearings and



four thrust races separate the clutch hub pinion assembly from the snap ring and the bearing cone. The external teeth of the sintered-metal clutch plates and the back plate are aligned with the internal teeth of the clutch housing gear. The back plate is retained in the clutch housing gear by an internal snap ring. The internal teeth of the steel clutch plates are aligned with the smaller diameter external teeth of the clutch hub pinion assembly. The larger diameter external gear teeth of each clutch hub pinion assembly is in constant mesh with the output gear.

9. MAIN HOUSING GROUP OF PARTS.

A. Main Housing Assembly. Two half housings two dowel pins and seventeen cap screws form the main housing assembly. The two half housings are dowel pin located prior to machining of the shaft bores. Therefore, these parts are a matched assembly and cannot be replaced separately.

B. Front Half Housing. The front half housing is a high quality casting that has integral mounting pads for the support of the marine transmission on the engine bed rails. The oil level gauge tube is installed in the front half housing and contains the oil level gauge.

C. Rear Half Housing. The rear half housing is indexed to the front half housing with two dowel pins, and secured together with an aerobic sealant and seventeen hex-head capscrews. Tapped pusher screw holes are machined in the rear half housing adjacent to the dowel pin holes to facilitate removal. Bearing bores for installation of the clutch shaft bearings and the output shaft bearing also are provided in the rear half housing. In addition, external mounting pads on the rear half housing permit the installation of the selector valve assembly, the pump mount, and the bearing retainer. The breather-filter cap is also installed in the rear half housing. A hex-head pipe plug installed in the bottom of the rear half housing functions as a drain plug for the marine transmission sump.

D. Bearing Retainer. The bearing retainer is secured to the rear half housing with six hex-head cap screws. The bearing retainer is installed around the output shaft, and bearing retainer shims are used to adjust the end play of the output shaft tapered roller bearings. "Loctite" plastic gasket material is used to prevent oil leakage around the bearing retainer. The bearing retainer oil seal is installed in the bearing retainer to prevent oil leakage past the output flange.

E. Bearing Support. The bearing support is secured to the front of half housing with six hex-head cap screws. The bearing support is installed around the input shaft, and bearing support shims are used to adjust the end play of the input shaft tapered roller bearings. "Loctite" plastic gasket material is used to prevent oil leakage around the bearing support. The bearing support oil seal is installed in the bearing support to prevent oil leakage past the input shaft.

10. OUTPUT GROUP OF PARTS.

A. Output Shaft. The larger diameter central area of the output shaft is tapered for the installation of the output gear. The output shaft tapered roller bearings are installed on the shaft on both sides of the output gear. One bearing cup is installed in the bearing bore of an integral web of the front half housing, and the other bearing cup is installed in a bearing bore in the rear half housing assembly. A hollowed dished oil retainer shield is fitted in the bottom of the front bearing bore to supply lubricating oil to both input and output bearings.

B. Output Gear. The output gear is installed on the tapered area of the output shaft between the output shaft tapered roller bearings. The output gear is in constant mesh with the forward clutch hub pinion assembly and the reverse clutch hub pinion assembly.

C. Output Flange. The output flange is spline-connected on the output shaft, and secured to the shaft by the lathe-cut rubber seal ring, the retainer washer, and the hex-head cap screw. The seal ring prevents oil leakage past the splined areas of the output shaft and the output flange. The output flange also provides for the installation of a six-bolt companion flange.

11. PUMP MOUNT GROUP OF PARTS.

The pump mount is installed on the rear half housing with four hex-head cap screws at the reverse clutch group of parts location. The pump mount shims between the pump mount and the rear half housing permit the proper end play adjustment to be made for the reverse clutch shaft tapered roller bearings. The pump mount also provides a mounting pad for the oil pump assembly. Two holes in the pump mount permit the connection of the lube oil connector tube and the main oil connector tube to be made to the main regulator valve body. A machined bore in the pump mount is provided for the installation of the filter screen.

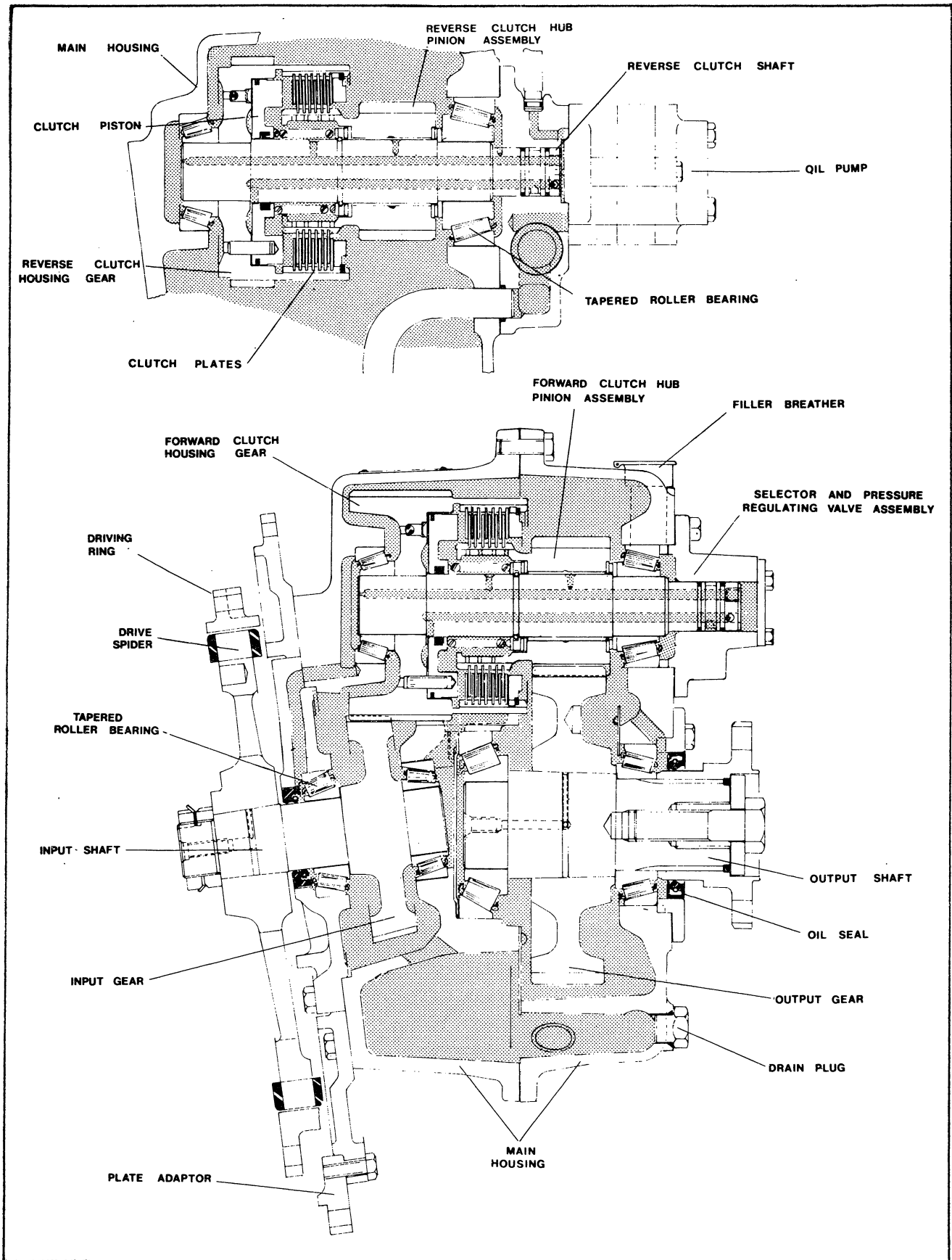

Figure 3. Model MG-507-A Marine Transmission - Cross Section Drawing.



12. OIL PUMP ASSEMBLY.

A. Oil pump Assembly. The oil pump assembly is a positive-displacement, gear-type pump that is tang driven by the reserve clutch shaft. The oil pump assembly is secured to the pump mount by a gasket and four hex-head cap screws. The oil pump assembly is driven at engine speed and has a rated capacity of 4.33 gpm at 2000 rpm.

B. Suction Tube. The suction tube connects the filter screen and the inlet port of the oil pump assembly.

13. SELECTOR VALVE ASSEMBLY.

A. General. The selector valve assembly is installed on the rear half housing of the marine transmission with three hex-head capscrews at the forward clutch group of parts location, against a circular spacer located in the bearing bore. The regulator valve body shims, between the selector valve assembly and the rear half housing, permit the proper end play adjustment to be made for the forward clutch shaft tapered roller bearings, including the a.m. spacer. The selector valve assembly consists of the selector valve group of parts and the main regulator valve group of parts assembled in a common valve bore in the main regulator valve body. The selector valve hydraulically functions by the mechanical movement of the shaft lever, and the main regulator valve controls main and lube oil pressure in the hydraulic system.

B. Selector Valve Group of Parts. The selector valve group of parts basically consists of the valve body, cover, cover gasket, shift lever, detent assembly plate and valve spool. The rotary-type selector valve, actuated by lever movement from the operator to one of three positions: "neutral", "forward" or "reverse" directs the oil flow to the selected clutch, automatically draining the opposite clutch at atmospheric pressure, through integral passages in the valve body bore. From the detented neutral position, the lever is moved 51 degrees against a positive stop to either forward or reverse clutch positions. The detent ball and plate assembly holds the valve in the selected position, aligning the desired circuit passages. An "O" ring seals the valve spool in the valve body from external leakage along the spool.

C. Main Regulator Valve Group of Parts. The main regulator valve group of parts consists of the piston, and a pair of springs. Shims, one or two usually, are placed behind the springs to increase the oil pressure rating to the desired range. The piston fits in the drilled end of the selector

valve spool. A large flange on the bottom of the piston operates against the springs when oil pressure is exerted on the top of the piston. As the piston moves downward towards its regulating point, it uncovers a port to the lubrication circuit. The overage oil from the regulating piston supplies the necessary lube pressure for the unit.

14. HOSE AND HEAT EXCHANGER.

No kit is available from Twin Disc but the following boat builders technical data should enable you to select and purchase a suitable heat exchanger.

HEAT EXCHANGER (H.E.) REQUIREMENTS AND GENERAL DATA	
MAX. MIN. PERMISSIBLE OIL TEMP. TO H.E.	150 - 120 °F.
MIN. RECOMMENDED TRANSFER CAPACITY	159
(Multiply by 1.25 for fresh water)	B.T.U. PER
(Multiply by 2.00 for raw water)	1000 R.P.M.
OIL TO HEAT EXCHANGER	2.20 .G.P.M.
(Use R.P.M. ratio for ratioing G.P.M.)	AT 1000 R.P.M.
MAX. PEAK OIL PRESSURE AT H.E.	385
(Use 1.5 times P.S.I. for proof test of H.E.)	P.S.I.
MAX. ALLOWABLE PRESSURE DROP ACROSS H.E. OIL PASSAGES WITH 300 S.U.S. AT MATCH POINT R.P.M.	30
	P.S.I.
WATER TO H.E. --- USE 1.5 TO 3.0 TIMES OIL G.P.M.	

DATA PURCHASER OF H.E. SHOULD PROVIDE :
STATE TYPE OF WATER TO BE SUPPLIED --- RAW OR FRESH. (Raw is open channel sea water.) (Fresh is closed engine jacket keel cooler water systems)
STATE MAX. YF. WATER INTO H.E. --- USUALLY USE 85 °F. FOR RAW WATER, 140 °F. FOR KEEL COOLER WATER AND UP TO 180 °F. FOR ENGINE JACKET WATER.
STATE MIN. G.P.M. WATER TO BE SUPPLIED. (Also state max. G.P.M. if over 1.5 times min. is expected.)
STATE MAX. P.S.I. WATER INTO H.E. (Ask supplier his expected pressure drop.)
REFERENCE EX4107 SERIES CHARTS.

15. GENERAL INFORMATION CHART.

The following table provides general information relative to marine transmission operation. These specifications must be observed to obtain proper operation of the marine transmission.

TABLE 2. GENERAL INFORMATION.

<p>OIL PRESSURE For 250 psi spring Normal 240 - 260 psi at 1800 rpm and 180° F. (Minimum 235 psi at cruising speed). For 300 psi spring Normal 300 - 320 psi at 1800 rpm and 180° F. (Minimum 280 psi at cruising speed). Cooling and Lube : 6 psi Min. at 1800 rpm and 180° F.</p>																			
<p>OIL CAPACITY 1.72 U.S. gallons, or fill to "Full" mark on gauge.</p>																			
<p>OIL SERVICE CLASS Use SAE-API service class CD engine oil which is certified by the oil company to pass TO-2. or C-3 Test Specification. Also approved is SAE-API service class CC engine oil, MIL-L-2104B.</p>																			
<p>OIL VISCOSITY</p> <table border="1" style="width: 100%; border-collapse: collapse;"> <thead> <tr> <th colspan="2" style="text-align: center;">Sump Temperature, also Oil Temperature into Heat Exchanger</th> <th rowspan="2" style="text-align: center;">Recommended Oil Viscosity</th> </tr> <tr> <th style="text-align: center;">During Start-up</th> <th style="text-align: center;">Steady Operating Conditions</th> </tr> </thead> <tbody> <tr> <td></td> <td style="text-align: center;">Below 150° F.</td> <td style="text-align: center;">This operating condition is not approved.</td> </tr> <tr> <td style="text-align: center;">32° F. Min.</td> <td style="text-align: center;">150° – 185° F.</td> <td style="text-align: center;">SAE viscosity number 30 engine oil.</td> </tr> <tr> <td style="text-align: center;">32° F. Min.</td> <td style="text-align: center;">175° – 210° F.</td> <td style="text-align: center;">SAE viscosity number 40 engine oil.</td> </tr> <tr> <td></td> <td style="text-align: center;">Above 210° F.</td> <td style="text-align: center;">This operating condition is not approved.</td> </tr> </tbody> </table>			Sump Temperature, also Oil Temperature into Heat Exchanger		Recommended Oil Viscosity	During Start-up	Steady Operating Conditions		Below 150° F.	This operating condition is not approved.	32° F. Min.	150° – 185° F.	SAE viscosity number 30 engine oil.	32° F. Min.	175° – 210° F.	SAE viscosity number 40 engine oil.		Above 210° F.	This operating condition is not approved.
Sump Temperature, also Oil Temperature into Heat Exchanger		Recommended Oil Viscosity																	
During Start-up	Steady Operating Conditions																		
	Below 150° F.	This operating condition is not approved.																	
32° F. Min.	150° – 185° F.	SAE viscosity number 30 engine oil.																	
32° F. Min.	175° – 210° F.	SAE viscosity number 40 engine oil.																	
	Above 210° F.	This operating condition is not approved.																	
<p>OIL AND FILTER CHANGE INTERVAL First element filter change should take place after 10 hours and thereafter every 1000 hours of operation for both filter element and oil, or 6 months, whichever occurs first.</p>																			
<p>FILTER SCREEN Remove and clean after first 10 hours and thereafter every 1000 hours of operation, or 6 months, whichever occurs first.</p>																			
<p>OIL PUMP CAPACITY 4.33 gpm at 2000 rpm.</p>																			
<p>MAXIMUM SPEED 3200 rpm.</p>																			
<p>SHIFTING LIMITS Continuous duty applications : "Neutral" to "Forward" or "Reverse" : 1500 rpm. Intermediate and pleasure craft applications : "Neutral" to "Forward" or "Reverse" : under 80% of engine governed rpm. Continuous duty applications : Shifting across "Neutral" 1000 rpm. Intermediate and pleasure craft applications : Shifting across "Neutral" : under 67% of engine governed rpm.</p>																			
<p>DRY WEIGHT Approximately 343 lbs. or 156 kgs.</p>																			

Section III. PRINCIPLES OF OPERATION

16. GENERAL.

A. Description. The models MG-507-A Marine Transmissions 7^o down angle configuration provide for near level installation are marine reverse and reduction transmissions available in five ratios : 1.101 : 1, 1.50 : 1, 1.98 : 1, 2.54 : 1, 2.99 : 1. Within their rated capacities, all ratios may be operated continuously in the forward and reverse propulsion directions. However, as stated previously, the Marine Transmission can only be installed on right-hand rotation engines ! The Marine Transmission is completely hydraulic in all phases - all bearings are oil lubricated, both clutches are engaged by high pressure oil, and both clutches are oil lubricated.

B. Direction of Drive. The input shaft always turns in engine direction and the forward clutch shaft always turns in anti-engine direction. Therefore, when the Marine Transmission is engaged in the forward position, the output shaft will turn in engine direction as the clutch hub pinion assembly installed on the output gear. When the Marine Transmission is engaged in the reverse position, the output shaft will turn in anti-engine direction.

17. POWER FLOW.

A. Neutral (fig. 4). When in neutral, all parts that rotate in the marine transmission while in this position, turn at 1.056 : 1, ratio of engine speed. The connecting member between the engine and the Marine Transmission is the driving ring. The drive spider is on the input shaft. The input gear is on the input shaft. Therefore the input gear turns at engine speed and in engine direction. The input gear is in constant mesh with the forward clutch housing gear, and turns the gear the clutch shaft and the sintered metal clutch plates at a.m. ratio of engine speed and in anti-engine direction. The forward clutch housing gear is in constant mesh with the reverse clutch housing gear, and the gear, the clutch shaft, and the sintered metal clutch plates rotate at 1.056 : 1, ratio of engine speed and in engine direction. The oil pump assembly which is connected to the end of the reverse clutch shaft, also

rotates at 1.056 : 1 of engine speed and in engine direction. Since neither forward or reverse clutch is engaged, there is no further power flow within the gear.

B. Forward (fig. 5). When forward speed is selected, all the marine transmission parts which were turning during neutral selection are still turning. However, when forward is selected, the forward clutch faced and metal plates are clamped together by the clutch piston and back plate. The internal teeth of the steel clutch plates are meshed with the smaller diameter external teeth of the clutch hub pinion assembly and turn the pinion gear at given ratio of engine speed and in anti-engine direction. The larger external gear teeth of the pinion gear are in constant mesh with the output gear which is press taper assembled on the output shaft. The output flange is spline-connected to the output shaft and, therefore, the flange rotates in engine direction when in forward. The output shaft and flange rotate at a speed that is reduced from the engine speed due to the overall ratio between the input gear and the output gear.

C. Reverse (fig. 6). When in reverse, all the marine transmission parts that rotated in neutral are still turning. However, when reverse is selected, the reverse clutch steel and faced plates are clamped together by the clutch piston and back plate. The internal teeth of the steel clutch plates are meshed with the smaller diameter external teeth of the clutch hub pinion assembly, and turn the pinion gear at engine speed and in engine direction. The larger diameter external gear teeth of the pinion gear are in constant mesh with the output gear which is press taper assembled on the output shaft. The output flange is spline-connected to the output shaft and, therefore, the flange rotates in anti-engine direction when in the reverse clutch position. The output shaft and the output flange rotate at a speed that is reduced from the engine speed due to the overall ratio between the input gear and the output gear.

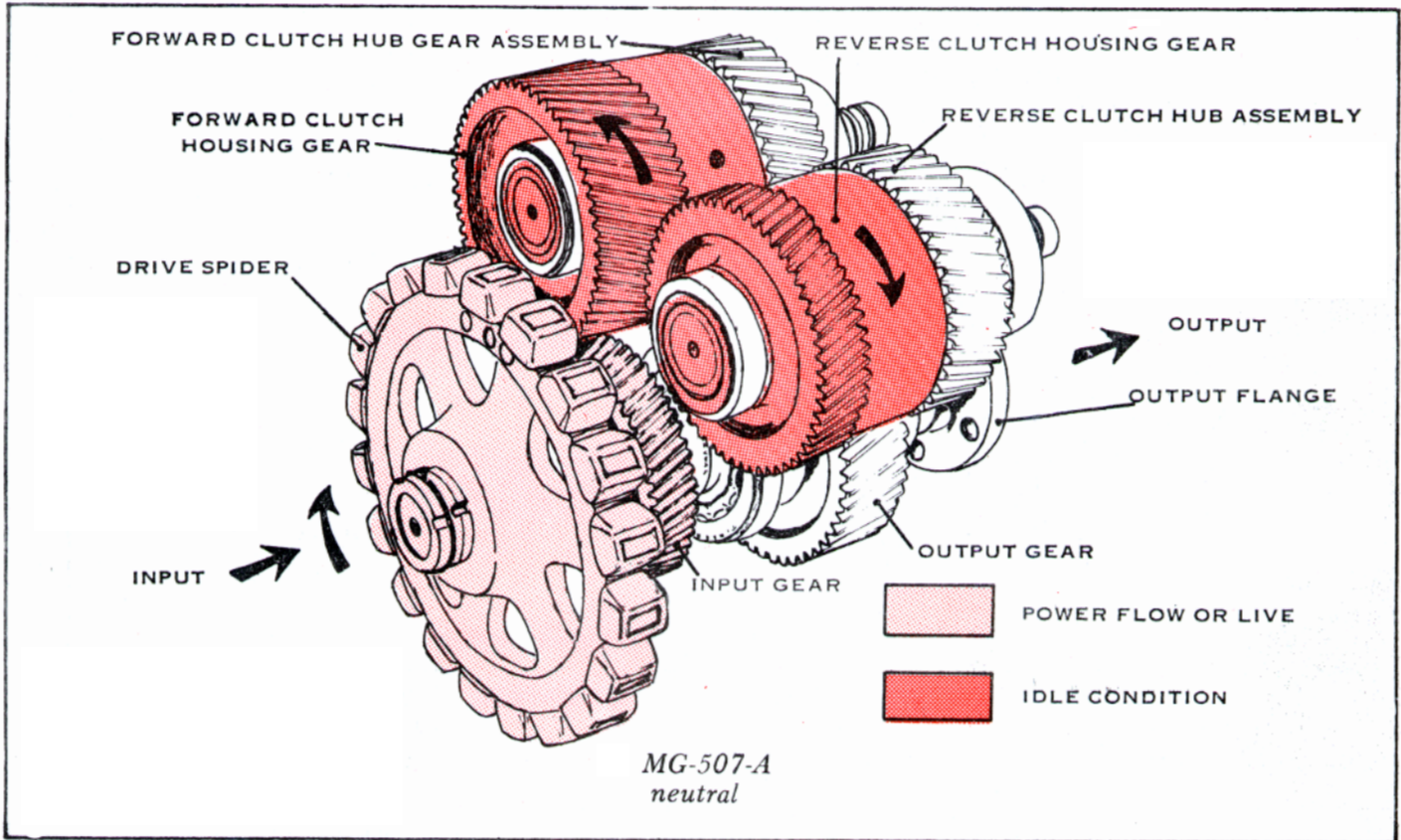

Figure 4. Model MG-507-A Marine Transmission Power Flow - Neutral - Schematic View.

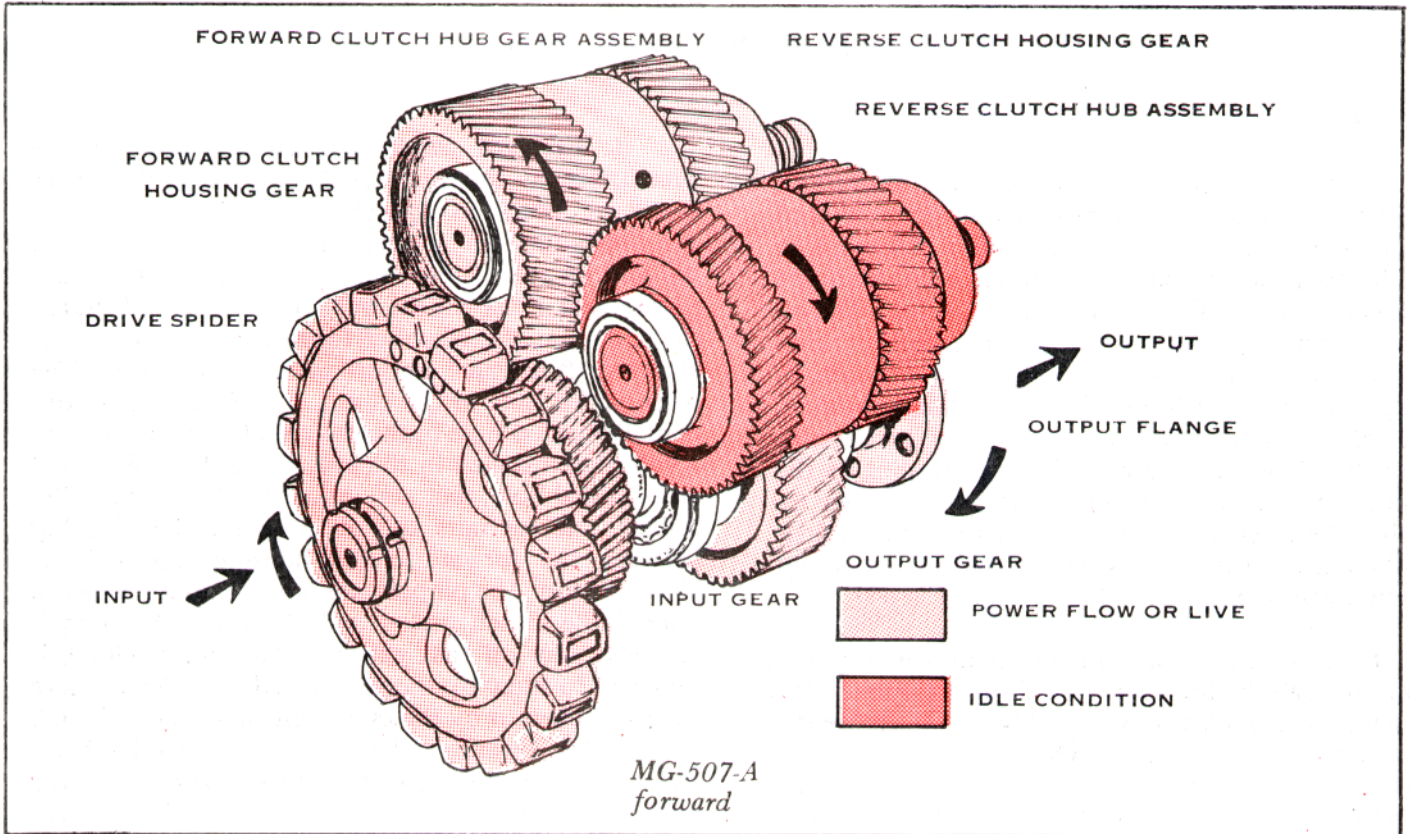

Figure 5. Model MG-507-A Marine Transmission Power Flow - Forward - Schematic View.

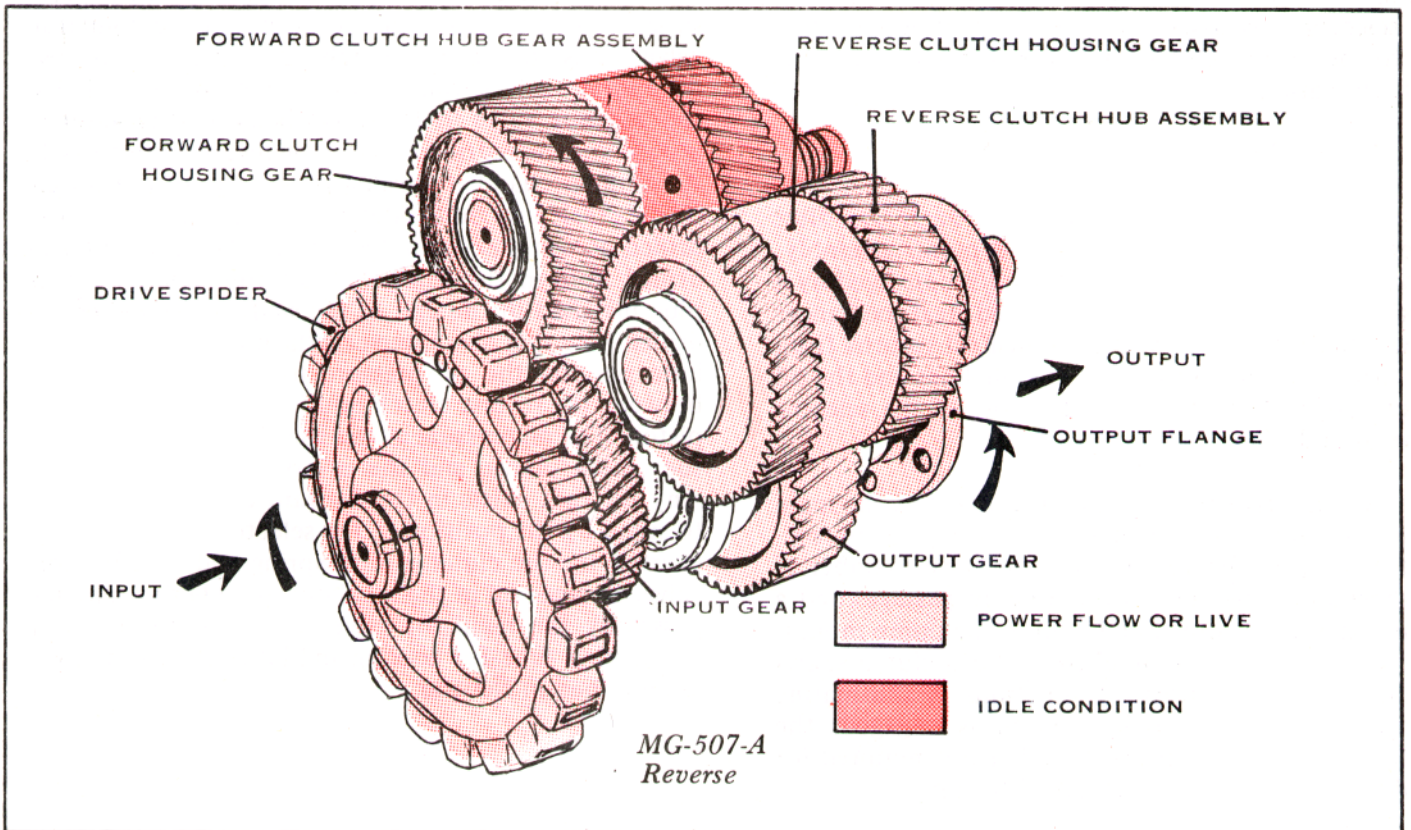

Figure 6. Marine Transmission Power Flow



Section IV. HYDRAULIC SYSTEM

18. GENERAL.

A. Description. The hydraulic system delivers oil pressure for clutch engagement, clutch cooling, and lubrication functions. The sump, which is located in the bottom of the housing, contains an adequate amount of oil for all functions of the system. The oil pump assembly pressurizes the oil for pressure requirements. The selector valve assembly functions as both a regulator and distributor for the hydraulic system. The selector valve assembly directs the oil to engage either the forward or reverse clutch depending on the position of the selector valve. The selector valve assembly also directs oil to the lube system. Piston rings on the ends of the clutch shafts separate the lube and clutch pressure oil.

B. External Oil Circuit. Oil is drawn from the sump through the filter screen and suction tube to the oil pump assembly. From the oil pump assembly the oil is conveyed by a flexible hose to the remotely-located heat exchanger where the oil is cooled. The cooled oil returns from the heat exchanger through a flexible hose and the oil filter assembly to the oil inlet port of the selector valve assembly. The oil tubes connecting the selector valve assembly to the pump mount convey oil to the reverse clutch shaft for clutch engagement and lubrication.

19. OIL FLOW.

Oil is drawn from the sump through the filter screen and suction tube to the oil pump assembly. From the oil pump assembly the oil is conveyed by a flexible hose to the remotely-located heat exchanger where the oil is cooled. The cooled oil returns from the heat exchanger through a flexible hose and the oil filter assembly to the oil inlet port of the selector valve assembly.

A. Neutral (fig. 7). Oil is pressurized by the main regulator valve in the regulator valve body to approximately 85 psi. Overage oil from the valve chamber of the regulator valve enters the lube oil passages and a connecting tube conveys lube oil to the pump mount. The lubricating oil is supplied to both clutch shafts for cooling and lubricating functions in the marine transmission. Since neither clutch is engaged, the remainder of the oil in the chamber not required for cooling and lubrication is returned to sump.

B. Forward clutch applied (fig. 8). Oil is pressurized by the main regulator valve in the regulator valve body to approximately 250 psi or 310 psi depending on springs used. Oil is routed by the selector valve spool in the valve body to an annular groove and cross drilled hole in the forward clutch shaft. An annular chamber formed in the rear of the clutch shaft is sealed on both sides by piston rings. The cross-drilled hole in the clutch shaft intersects a horizontally-drilled hole in the shaft that is terminated by a ball plug installed in the end of the shaft. A second cross-drilled hole, that also intersects the horizontally-drilled hole, permits the oil to enter the chamber between the forward clutch housing gear and the clutch piston. The oil pressure moves the clutch piston against the clutch plates, and the forward clutch is engaged. Any oil that exists in the reverse clutch is returned to sump by the position of the selector valve the force exerted by the clutch piston spring and a ball dump valve. Overage oil in the regulator valve body chamber passes by the regulator valve and enters the lube oil tube for cooling and lubricating functions as described in Neutral.

C. Reverse clutch applied (fig. 9). Oil is pressurized by the main regulator valve in the regulator valve body to approximately 250 psi or 310 psi depending on springs used. Oil is routed by the selector valve in the valve body to the annular groove and cross drilled hole in the reverse clutch shaft. An annular chamber formed in the rear of the clutch shaft is sealed on both sides by piston rings. The cross-drilled hole in the clutch shaft intersects a horizontally-drilled hole in the shaft that is terminated by a ball plug installed in the end of the shaft. A second cross-drilled hole that also intersects the horizontally-drilled hole permits the oil pressure to enter the chamber between the reverse clutch housing gear and the clutch piston. The oil pressure moves the clutch piston against the clutch plates, and the reverse clutch is engaged. Any oil that exists in the forward clutch is returned to sump by the position of the selector valve the force exerted by the clutch piston spring and a ball dump valve. Overage oil in the regulator valve body chamber passes by the regulator valve and enters the lube oil connecting tube for cooling and lubricating functions as described in Neutral.

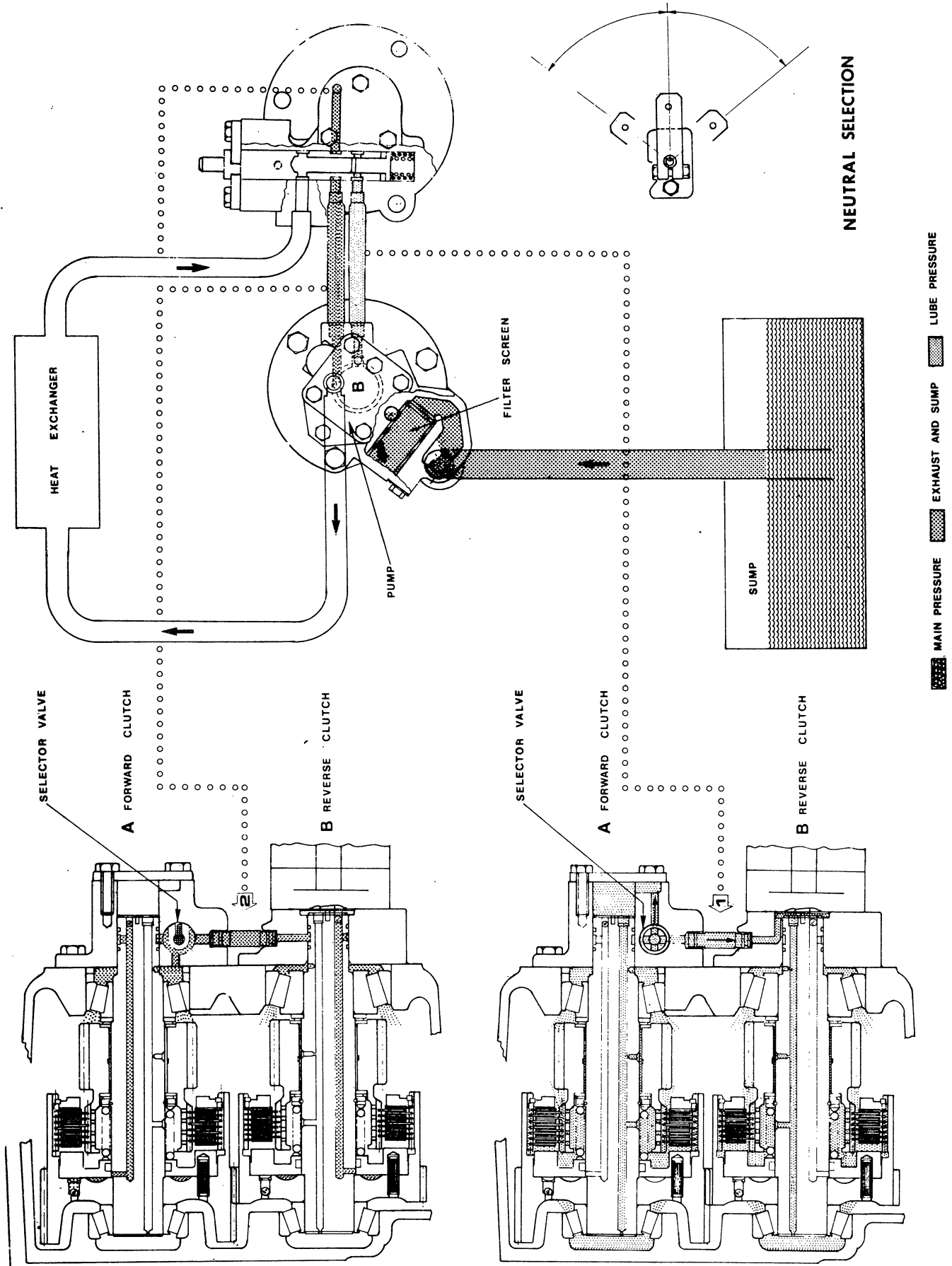

Fig. 7 . Marine Transmission oil flow - Neutral - Schematic drawing.

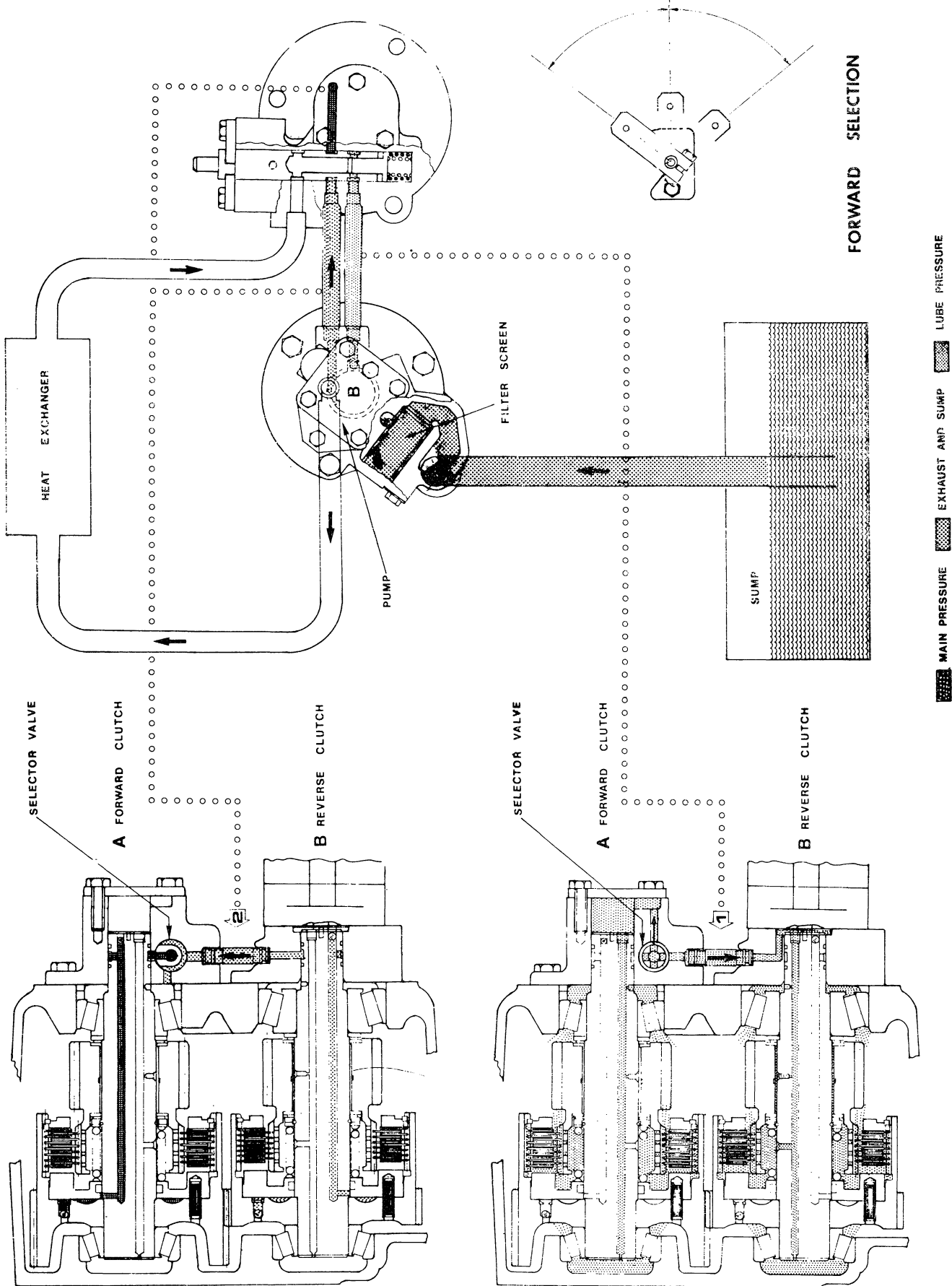

Fig 8 . Marine Transmission oil flow - Forward clutch applied - Schematic drawing.

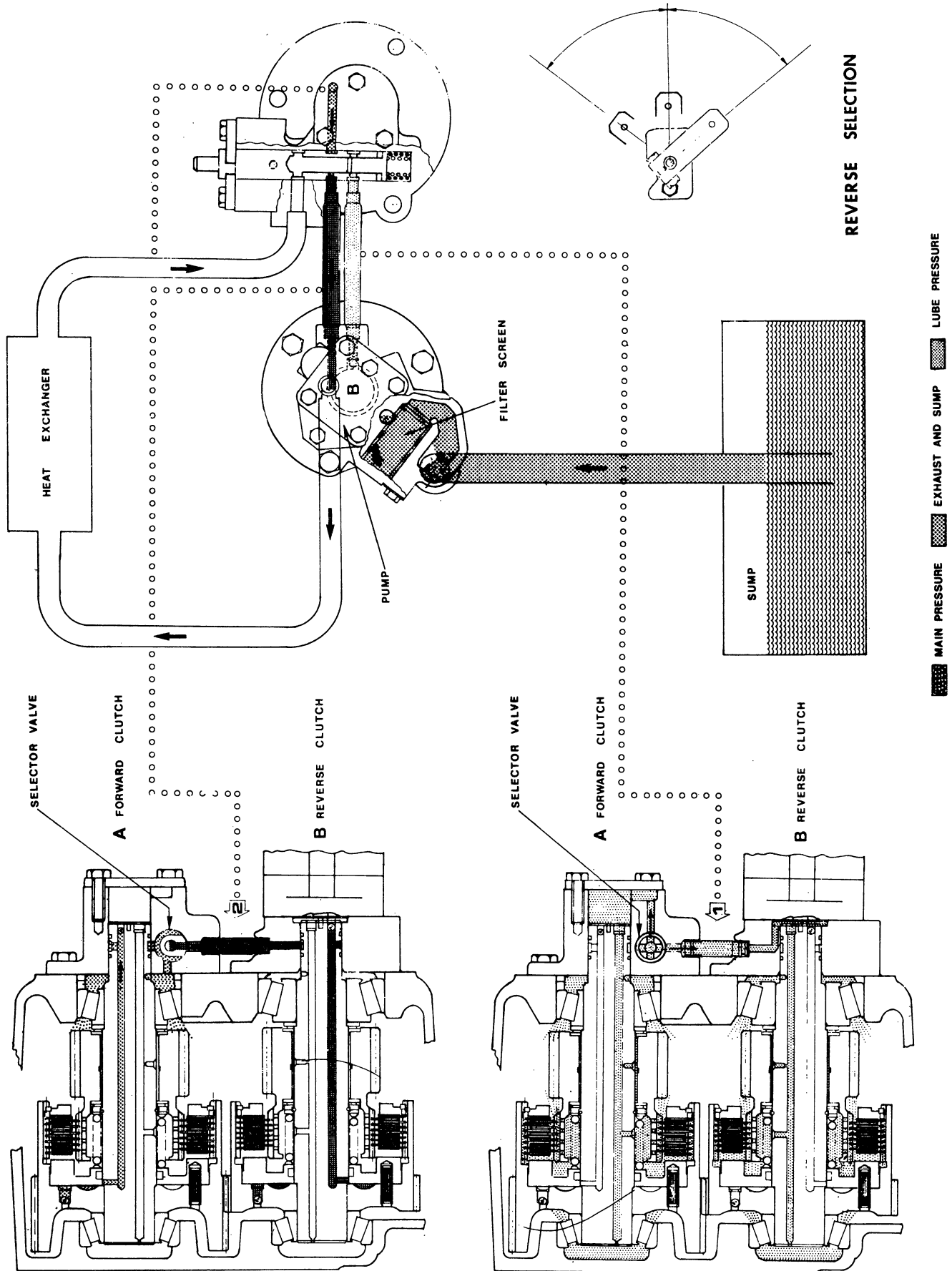

Fig. 9 . Marine Transmission oil flow - Reverse clutch applied - Schematic drawing.



20. GENERAL.

A. Lubrication. All moving parts of the Marine Transmission are lubricated by the oil within the sump as it travels throughout the hydraulic system. The preventive maintenance required to keep the gear functioning properly is slight; however, it is very important that the following directions be complied with.

B. Overhaul Interval. A complete overhaul of the Marine Transmission should be made at the same time that the engine is overhauled. All parts showing signs of great wear, fatigue, etc., should be replaced at that time.

21. HYDRAULIC SYSTEM.

A. Oil Capacity and Weight. The oil capacity of the Marine Transmission without a heat exchanger is 1.72 gallons, or to the "Full" mark on the oil level gauge. This does not include lines to and from the heat exchanger as well as the heat exchanger itself. The oil used in the marine transmission should be of the quality and type recommended on the tag and instruction plate attached to the unit. (see also table 2. General information).

B. Oil Level. The oil level should be checked daily using the oil level gauge in the marine transmission. Check the oil level with the engine at idle speed and the marine transmission in "Neutral". The oil level must be maintained at the "Full" mark on the oil level gauge.

C. Oil Change Interval. The oil must be changed every 1000 hours of operation. Boats that are placed in dry dock or storage for periods of three months or more, should have the oil changed in the marine transmission prior to a return to active use.

D. Draining. When a complete oil change of the hydraulic system is required, it is necessary to drain the oil from the heat exchanger and connecting hoses as well as the marine transmission sump. In addition, if the Marine Transmission is equipped with an oil filter assembly, the filter and connecting hoses must be drained and the filter element replaced. Alternate methods of draining the marine transmission sump of oil are possible as described below :

(1) **Gravity Drain.** Position a 2 gallon container beneath the hex-head pipe plug in the bottom of the rear half housing, and remove the plug. Allow

sufficient time for the marine transmission oil to drain from the sump, and then install the plug securely in place.

(2) **Suction Drain.** A suction pump can be used to drain the marine transmission sump. The oil level gauge tube is serrated to accommodate a suction hose. Remove the oil level gauge, and install a suction hose on the oil level gauge tube. Operate the suction pump until the marine transmission oil has been removed from the sump. After suction draining, remove the pump and hose, and install the oil level gauge in the tube.

E. Filling. Make certain the drain plug is tight. Use the recommended quality, type, and weight oil, and fill the marine transmission sump with 1.72 U.S. gallons of oil. Pour the oil slowly into the breather filler cap. After filling, start the engine and permit the oil to attain proper operating temperature. Shift the marine transmission several times in "Forward" and "Reverse" positions. Check the oil level. With the engine at idle speed and the marine transmission in "Neutral", the oil level must be to the "Full" mark on the oil level gauge.

22. COMPONENT PARTS.

A. Filter Screen. The filter screen is installed in the pump support, and extends into the marine transmission.

(1) **Cleaning Interval.** The filter screen should be removed and cleaned every 1000 hours of operation at the same time that the oil is changed.

(2) **Removal.** Remove the cover plate screw, the cover plate, and filter screen from the pump mount.

(3) **Cleaning.** Clean the filter screen in clean diesel fuel insuring that all foreign matter is removed from the holes in the filter screen.

(4) **Installation.** Install the filter screen in the pump mount, and attach the cover to the pump mount of the marine transmission with the hex-head capscrew and washer.

B. Heat Exchanger and Hoses. Disconnect the hoses from the heat exchanger every 1000 hours of operation at the same time that the oil is changed. Drain the hoses and the heat exchanger of all oil. After draining, connect the hoses to the heat exchanger.

<i>Symptom</i>	<i>Cause</i>	<i>Remedy</i>
<p>2. <i>No Oil Pressure.</i></p>	<p>2-1. Low oil level or empty sump.</p> <p>2-2. Fully clogged filter screen.</p> <p>2-3. Damaged suction tube.</p> <p>2-4. Damaged or worn oil pump assembly.</p> <p>2-5. Broken clutch shaft.</p>	<p>2-1. Check gaskets, hoses, and seals for oil leakage. Replace parts causing leakage and fill marine transmission sump.</p> <p>2-2. Remove and clean filter screen.</p> <p>2-3. Disassemble and inspect suction tube. Replace parts as required.*</p> <p>2-4. Remove and replace oil pump assembly.</p> <p>2-5. Refer to Remedy 1-5.</p>
<p>3. <i>High Oil Pressure.</i></p>	<p>3-1. Stuck main regulator piston.</p>	<p>3-1. Refer to Remedy 1-2.</p>
<p>4. <i>Overheating.</i></p>	<p>4-1. Insufficient heat exchanger capacity.</p> <p>4-2. Insufficient cooling water flow.</p> <p>4-3. Slipping clutch.</p> <p>4-4. Oil level too high.</p> <p>4-5. Improper oil in sump.</p> <p>4-6. Clutch piston spring broken.</p> <p>4-7. Clutch plates warped.</p> <p>4-8. Improper bearing adjustment with shims (especially after overhaul).</p>	<p>4-1. Replace present heat exchanger with heat exchanger of sufficient capacity.</p> <p>4-2. Replace lines and/or hoses with larger inside diameter lines and/or hoses.</p> <p>4-3. Low oil pressure (Symptom 1). Remove marine transmission, disassemble, and inspect for worn clutch plates.</p> <p>4-4. Correct oil level.</p> <p>4-5. Drain marine transmission, and fill with proper oil.</p> <p>4-6. Refer to Remedy 1-5.</p> <p>4-7. Refer to Remedy 1-5.</p> <p>4-8. Check end play of shafts, and make proper shim adjustments.</p>
<p>5. <i>Excessive Noise.</i></p>	<p>5-1. Air leak in suction side of system.</p>	<p>5-1. Tighten all fittings and/or replace a damaged tube.*</p>

* Special rolling tools are required.



Section VI. TROUBLE SHOOTING

24. GENERAL.

This section of the maintenance manual has been prepared to assist maintenance personnel in locating faults in the marine transmission. When investigating these faults, always remember to consider the entire power package.

25. PRESSURE AND TEMPERATURE CHECKS.

A. Main Pressure. The main pressure, which is used to apply the clutches, can be checked by installing a pressure gauge with a range of 0 to 300 psi or 0 to 400 psi depending on springs used in the hydraulic system at the pressure pick-up point (1/8-27 NPTF thread) of the selector valve. Normally, the main pressure should be between 245 and 255 or 300 to 320 psi at 1800 rpm engine speed and 180 degrees F temperature, and not less than 235 psi or 280 psi minimum (depending on springs used) at cruising speed.

B. Cooling and Lubrication Pressure. The lubrication and cooling oil pressure is the overage oil from

the clutch pressure regulator valve in the selector valve body. No pressure check is specified. The pressure varies from 1,5 psi minimum to 16 psi maximum which is ample for the marine transmission lubrication.

C. Temperature. The temperature of the oil can be checked by installing a temperature gauge with a range of 0 degrees to 300 degrees F. in the hydraulic system, in the line between the oil pump assembly and the heat exchanger. Thus, temperature readings taken will closely reflect the temperature of the oil within the marine transmission sump. Readings taken should register between 150 degrees F. and 180 degrees F. 210 degrees F. is maximum and 150 degrees F. minimum recommended operating temperatures.

26. TROUBLE SHOOTING CHART.

The trouble shooting chart (Table 3) is organized in three columns. Proper use of the chart will aid in the rapid determination and repair of any functional difficulties that may occur.

Table 3. Trouble Shooting

Symptom	Cause	Remedy
1. Low Oil Pressure.	1-1. Partially clogged filter screen.	1-1. Remove and clean filter screen.
	1-2. Stuck main regulator piston.	1-2. Remove main regulator valve parts from valve body, and clean parts.
	1-3. Broken or worn piston rings on clutch shafts.	1-3. Remove pump mount and selector valve assembly from rear cover. Remove piston rings from clutch shafts. Install new piston rings on clutch shafts.
	1-4. Damaged or worn oil pump assembly.	1-4. Remove and replace the oil pump assembly.
	1-5. Damaged or worn clutch piston rings.	1-5. Remove marine gear. Disassemble clutches, and replace damaged or worn parts.
	1-6. Scored valve bore in selector valve assembly.	1-6. Remove selector valve assembly. Disassemble selector valve assembly and inspect valve bore.
	1-7. Plugged orifice of check valve in selector valve assembly.	1-7. Remove selector valve cover. Clean the orifice, or replace the check valve.
	1-8. Broken spring in selector valve assembly.	1-8. Remove plug at the bottom of selector valve body. Remove rate of rise piston and springs. Inspect springs and replace broken springs.

C. Oil Filter Assembly. If an oil filter assembly is used in the hydraulic system, the filter and connecting hoses must be drained every 1000 hours of operation and the filter element must be replaced. Accomplish these procedures at the same time that the oil is changed.

23. PERIODIC VISUAL INSPECTION.

A. General. Frequent inspection of the mounting parts of the marine transmission is recommended. Replace any damaged parts.

B. Heat Exchanger and Oil Filter Connecting Lines. Inspect the heat exchanger and oil filter connecting lines for leaks, sponginess, or other damage. Replace a damaged line.

C. Pressure and Temperature Gauge Assemblies. Periodically inspect the pressure and temperature gauge assemblies for damage. Replace a damaged gauge. If a gauge is suspected of being inaccurate, replace the gauge with one of proven accuracy.



<i>Symptom</i>	<i>Cause</i>	<i>Remedy</i>
<p>6. <i>No Neutral.</i></p>	<p>5-2. Worn gear teeth or splines on marine transmission parts.</p>	<p>5-2. Overhaul marine transmission. Replace worn parts.</p>
	<p>5-3. Bearing failure.</p>	<p>5-3. Overhaul marine transmission. Replace damaged parts.</p>
	<p>5-4. Worn or damaged rubber blocks.</p>	<p>5-4. Remove marine transmission. Replace worn or damaged rubber blocks.</p>
	<p>5-5. Excessive bearing end play.</p>	<p>5-5. Check and reset end play.</p>
	<p>6-1. Clutch plates warped.</p>	<p>6-1. Refer to Remedy 1-5.</p>
	<p>6-2. Clutch piston spring broken and jammed.</p>	<p>6-2. Refer to Remedy 1-5.</p>
<p>7. <i>Harsh Engagement.</i></p>	<p>6-3. Selector valve linkage incorrect.</p>	<p>6-3. Check linkage and adjust.</p>
	<p>6-4. Scored bore in valve body of selector valve assembly.</p>	<p>6-4. Refer to Remedy 1-6.</p>
<p>8. <i>Leakage Between Front Housing and Rear Housing.</i></p>	<p>7-1. Air in oil.</p>	<p>7-1. Correct air leaks in suction side of system. Change oil to proper type.</p>
	<p>7-2. Binding clutch piston.</p>	<p>7-2. Refer to Remedy 1-5.</p>
<p>9. <i>No Pressure and No Output Power.</i></p>	<p>8-1. Failure of the anaerobic plastic gasket compound.</p>	<p>8-1. Remove marine transmission. Disassemble, clean and apply new compound.</p>
	<p>9-1. Input shaft broken.</p>	<p>9-1. Overhaul marine transmission. Replace broken or damaged parts.</p>
	<p>9-2. Drive spider broken.</p>	<p>9-2. Refer to Remedy 9-1.</p>
<p>9-3. Drive spider or input gear loose on input shaft.</p>	<p>9-3. Drive spider or input gear loose on input shaft.</p>	<p>9-3. Refer to Remedy 9-1.</p>

Section VII. OIL SEAL REPLACEMENT**27. PRIOR TO REPLACEMENT.**

A. General. If it becomes necessary to replace the bearing retainer oil seal (fig. 63, 21) because of leakage, this can be accomplished without removing the marine transmission from the engine by following the procedure below.

B. Draining. In most installations, it will be necessary to drain the marine transmission sump of oil in order to accomplish oil seal replacement. Drain the oil by following the procedure described in paragraph 21D.

C. Output Flange Clearance. Scribe an aligning mark across the outside diameter of the output flange (fig. 63, 22) and the companion flange for installation purposes. Remove the bolts and nuts that secure the companion flange to the output flange. Slide the propeller shaft rearward until there is sufficient clearance for the removal of the output flange.

28. OIL SEAL REPLACEMENT.

A. Removal. Remove the capscrew (fig. 63, 25) retainer washer (24) shim (26), and the seal ring (23) from the output flange and the output shaft (26). Discard the seal ring. Remove the spline-connected output flange from the output shaft. It may be necessary to use a gear puller to accomplish this removal. Remove the bearing retainer oil seal (21) from the bearing retainer (20). Discard the oil seal.

B. Installation. Install a new bearing retainer oil seal (fig. 63, 21) in the bearing retainer (20). The oil seal must be installed flush with the rear face of the bearing retainer, and the lip of the seal must point towards the output gear (17). Carefully install the output flange (22) on the splines of the output shaft (16). *Do not damage the lip of the oil seal during this procedure.* Secure the output flange on the output shaft with a *new* lathe-cut rubber seal ring (23) the shim (26), the retainer washer (24), and the 7/8-9 hex-head capscrew (25). Tighten the capscrew to 405, 450 lbs.-ft. torque. Check the output shaft end play; end play must be between 0.003 and 0.005.

29. AFTER REPLACEMENT.

A. General. After replacement of the bearing retainer oil seal (fig. 63, 21) has been carried out, and the output shaft end play has been verified as being correct, the following procedures of drive line connection and oil filling of the marine transmission sump can be completed.

B. Drive Line Connection. Slide the propeller shaft and the companion flange forward against the output flange (fig. 63, 22). Align the scribed marks on the companion flange and the output flange. Secure the flanges together with the bolts and nuts previously removed.

C. Filling. Fill the marine transmission sump with oil by following the procedure described in paragraph 21E.

Section VIII. REMOVAL**30. PRIOR TO REMOVAL.**

A. Hydraulic System. Drain the hydraulic system of oil (paragraph 21 D).

B. Connecting Linkage. Disconnect all connecting linkage and lines to the marine transmission.

C. Support. Support the marine transmission with a hoist, or other suitable equipment, prior to the removal of any mounting parts.

LIFTING BOLT HOLES PROVIDED ON TWIN DISC PRODUCTS.

Most Twin Disc products have provisions for attaching lifting bolts. The holes provided are always of adequate size and number to safely lift the Twin Disc product.

These lifting points should not be used to lift the complete power unit. Lifting excessive loads at these points could cause failure at the lift point (or points) and result in damage or personal injury.

31. REMOVAL.

A. Output Flange Connection. Scribe an aligning mark across the outside diameter of the output flange and the companion flange for installation purposes. Remove the bolts and nuts that attach the output flange to the companion flange. After the removal of attaching parts, move the propeller shaft rearward until there is sufficient clearance for marine transmission removal.

B. Engine Bedrail Connections. Disconnect the mounting brackets installed on the engine bedrails from the mounting pads of the marine transmission or from the engine bedrails.

C. **Engine Connection.** Remove the hex-head capscrews that secure the housing of the marine transmission to the engine flywheel housing. Slide the marine transmission rearward until the rubber blocks on the drive spider are clear of the driving ring installed on the engine flywheel. Remove the marine transmission. Remove the driving ring from the engine flywheel only if its replacement is necessary.

Section IX. DISASSEMBLY

32. MISCELLANEOUS EXTERNAL PARTS.

A. Remove the oil level gauge (fig. 62, 11) from the oil level gauge tube (10). Remove the oil level gauge tube (10) from the main housing (9). Remove the drain plug (50) from the main housing (9).

B. Remove the breather cap (fig. 62, 16) from the rear half housing.

C. If replacement of the name plate (fig. 62, 6) is necessary, remove the four drive screws (5) that secure the name plate to the main housing. Remove the name plate and transfer the data stamped on the old plate to a new replacement name plate.

D. If replacement of the rotation indicator plate (fig. 62, 14) is necessary, remove the two drive screws (13) that secure the rotation indicator plate to the adaptor plate. Remove the rotation indicator plate.

E. Remove the pipe plug (fig. 62, 1) from the housing.

F. Remove the capscrew, washer and strainer cover (fig. 62, 46). To facilitate the removal of the strainer cover insert the removed capscrew (fig. 62, 49) into the tapped hole provided in the cover and pull out the assembly, "O" ring included (fig. 62, 47). Remove the strainer (fig. 62, 45) from the pump mount bore.

G. Remove the four hex-head capscrews (fig. 62, 41) that secure the oil pump assembly (40) to the pump mount. Remove the oil pump assembly and the oil pump gasket (42) from the pump mount. Discard the gasket. Disassemble the parts *only if replacement of parts is necessary.*

H. Remove the hex-head capscrew (fig. 63, 25) the shim (26) and the retainer washer (26) that secure the output flange (22) on the output shaft (16). Use a standard gear puller and remove the output flange (22) from the output shaft (16). Remove the lathe cut ring (23) from the output flange (22). Discard the seal ring.

I. Loosen the hex-head capscrew and nut (fig. 62, 18, 20) remove selector lever (19). Remove the three hex-head capscrews (29) and (34) that secure the selector valve assembly (30) to the rear half housing (9). Remove the three hex-head capscrews (43) that secure the pump mount (44) to the rear half housing (9). Simultaneously, remove the pump mount and selector valve assembly from the rear half housing. Remove the two connector rubes (38) and four "O" ring seals (37) from between the pump mount.

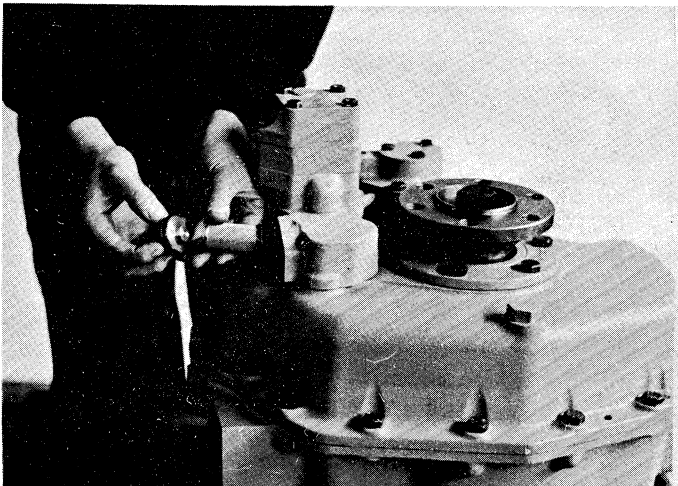

Fig. 10 . Pump Suction Filter Screen and Cover Plate removal.

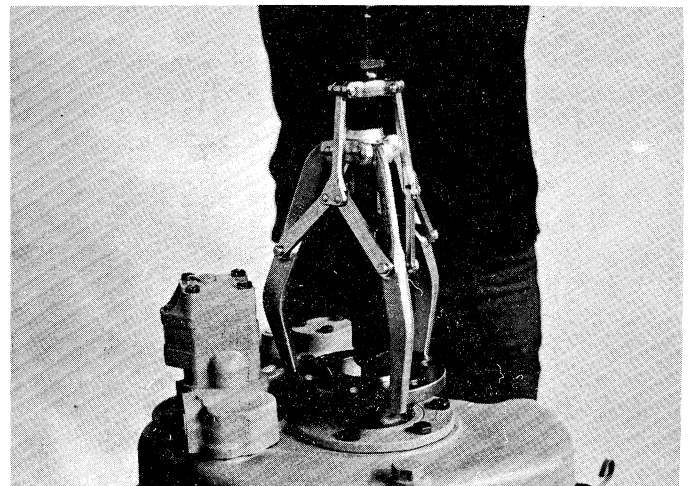

Fig. 11 - . Removing Output Flange.

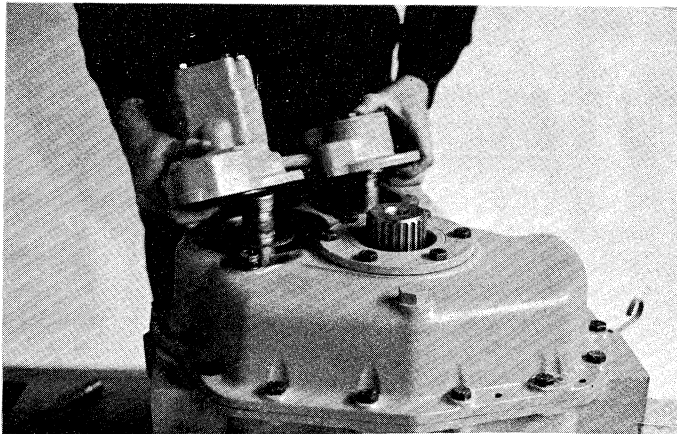

Fig. 12 . . Removing Pump Mount and Valve body together.

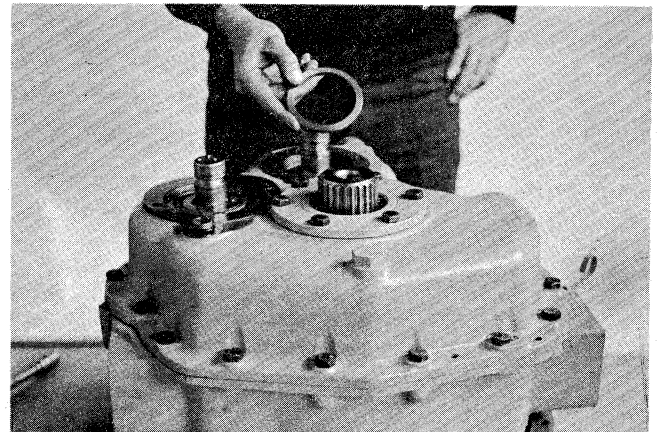

Fig. 13 . Removing Spacer from forward clutch bearing.

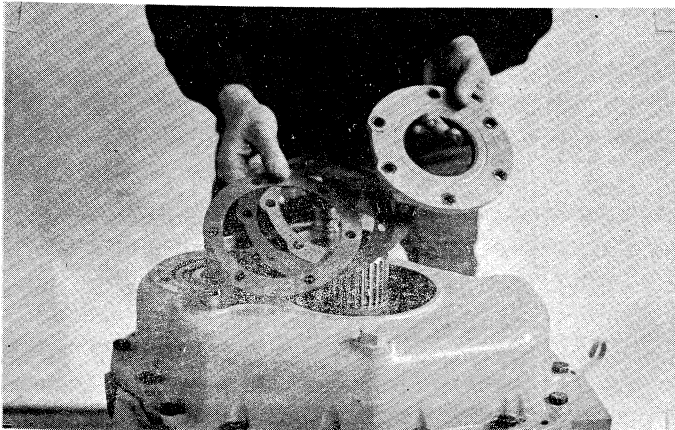

Fig. 14 . Output Shaft bearing retainer and Shims removed.

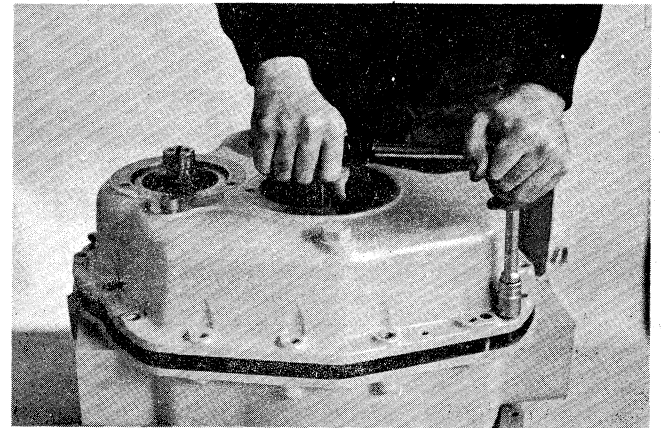

Fig. 15 . Using Pusher Screws to remove Rear half housing

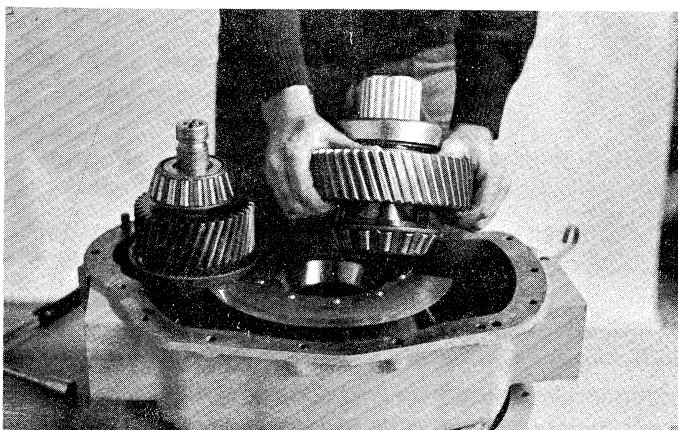

Fig. 16 . Removing Output Shaft and Gear assembly.

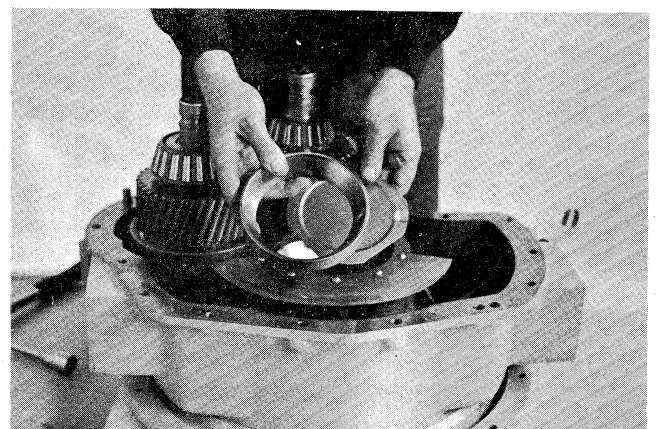

Fig. 17 . Removing output Shaft bearing cup and oil Shield.

Remove the pump mount shims (39) and "O" ring (52) and valve body shims (36) from the rear half housing.

J. Disassemble the selector valve assembly as follows. Remove the three hex-head capscrews (fig. 62, 33) and remove the valve body centre bore cover (32) and gasket (31) from the valve body (30). Remove the two hex-head capscrews (17) and remove the detent plate (21) from the valve body. Remove the valve spool (24), regulating valve piston (25), springs (26) and (35) and shim (27) from the valve bore in the valve body. Remove the "O" ring (23) from the valve spool (24). Remove pipe plug (28) from the valve body.

Procedure for selector valve with automatic rate of pressure rise :

Disassemble the selector valve assembly as follows. Remove the three hex-head capscrews (fig 62, 42, 47, 48) and remove the valve body cover (43) and gasket (36) from the valve body (34). Remove the check valve (35) from the cover. Remove the two hex-head capscrews (22) and remove the detent plate (30) from the valve body. Remove the valve spool (31) and remove the "O" ring (32) from the valve spool (31). Remove the snap ring and plug pressure rise. Discard the "O" ring from plus pressure rise. Remove the pressure rise piston and springs from the valve bore in the valve body.

L. Remove the seventeen hex-head capscrew (fig. 62, 53) that secure the two half housings together. Use two M 10 x 1,5 pusher screws, and remove the rear half housing from the front housing. Do not remove the two dowel pins (2) from the front housing. Remove the bearing cups of the output shaft tapered roller bearing (fig. 63, 18) the forward clutch shaft tapered roller bearing (fig. 64, 25) and its spacers and the reverse clutch shaft tapered roller bearing (fig. 65, 25) from the rear housing *only if replacement of parts is necessary*.

33. OUTPUT GROUP OF PARTS.

A. Remove the output shaft group of parts from the front housing. Remove the bearing cup of the output shaft tapered roller bearing (fig. 63, 15, 18) from the housing *only if replacement of parts is necessary*.

B. Use a bearing puller with a flat steel spacer, and remove the bearing cones (fig. 15, 18) of the output shaft group of parts.

C. Use special tool TD 300350 to remove output gear from the output shaft.

34. FORWARD AND REVERSE CLUTCH GROUP OF PARTS.

A. Remove the reverse clutch group of parts from the housing. Remove the bearing cup of the reverse clutch shaft tapered roller bearing (fig 65, 1, 25) from the housing *only if replacement of parts is necessary*.

B. Remove the forward clutch group of parts from the housing. Remove the bearing cup of the forward clutch shaft tapered roller bearing (fig. 64, 1, 25) from the housing *only if replacement of parts is necessary*.

C. The following procedure describes the disassembly of the forward clutch group of parts. The procedure for the disassembly of the reverse clutch group of parts is identical.

(1) Place the forward clutch group of parts on a suitable surface so that the rear end of the clutch shaft is up. The surface should contain a hole or slot to permit the entire circumference of the forward clutch housing gear (fig. 64, 2) to rest upon the surface.

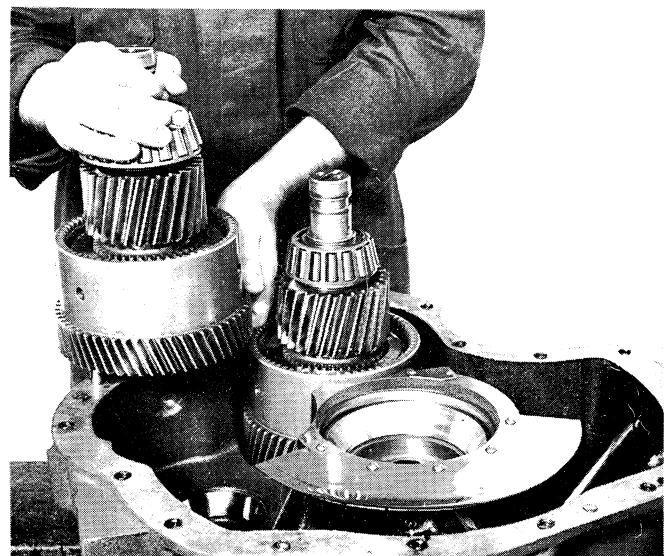

Fig. 18 . Removing the Reverse Clutch assembly.

(2) Remove the two piston rings (fig. 64 ,27) from the clutch shaft (19). Discard the piston rings.

(3) Place a cupped steel spacer over the end of the clutch shaft to prevent damage. Carefully, position a bearing puller on the pinion of the clutch shaft. Remove the bearing cone from the clutch shaft (fig. 64 ,25), together with the thrust races needle thrust bearing (fig. 64,24,23,22) and the pinion assembly (fig. 64,20,21)

(4) Remove the thrust race (18), the thrust needle bearing (17), and the thrust race (16) from the clutch shaft.

(5) Remove the internal snap ring (fig. 64 ,12) that secures the back plate (11) in the forward clutch housing gear (2). Remove the back plate the seven sintered metal clutch plates (10), and the steel clutch plates (9) from the forward clutch housing gear.

(6) Carefully compress the clutch spring with special tool TD 300342 or T 16752 and remove the external snap ring (fig. 64 ,15) that retains the clutch piston spring (fig. 64 ,13) through a steel washer (fig. 64 ,14) in position over the clutch shaft. Use caution as the snap ring is under tension.

(7) Remove the spring and the washer from the shaft. Remove the clutch piston (fig. 64 ,7) from the clutch shaft using special tools TD 300323 and remove the "O" ring (8) and the lathe cut ring (6) from the clutch piston. Discard both rings.

(8) Use a bearing puller with a flat steel spacer, and remove the bearing cone of the clutch shaft tapered roller bearing (fig. 64 ,1) from the clutch shaft *only if replacement of parts is necessary*. Removal of this bearing destroys it for further service.

(9) *Do not remove* the clutch housing gear (fig. 64, 2) from the clutch shaft. Shaft and gear are replaceable as an assembly only.

(10) Unless necessary for parts replacement, do not remove the dowel pin (fig. 64 ,5) and the ball dump valve assembly (fig. 64,4 ,3) from the clutch housing gear. Note that the self locking retaining ring (fig. 64 ,4) is NOT reusable.

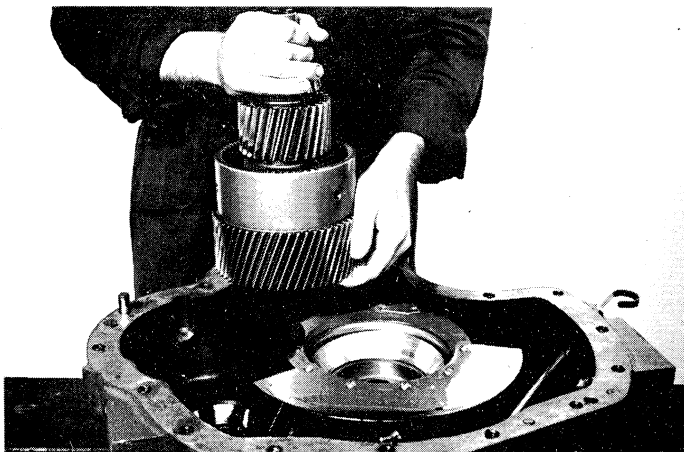

Fig. 19 . Removing the Forward Clutch assembly.



Fig. 20 . Pulling the Rear Bearing Cone from the Forward Clutch Shaft.

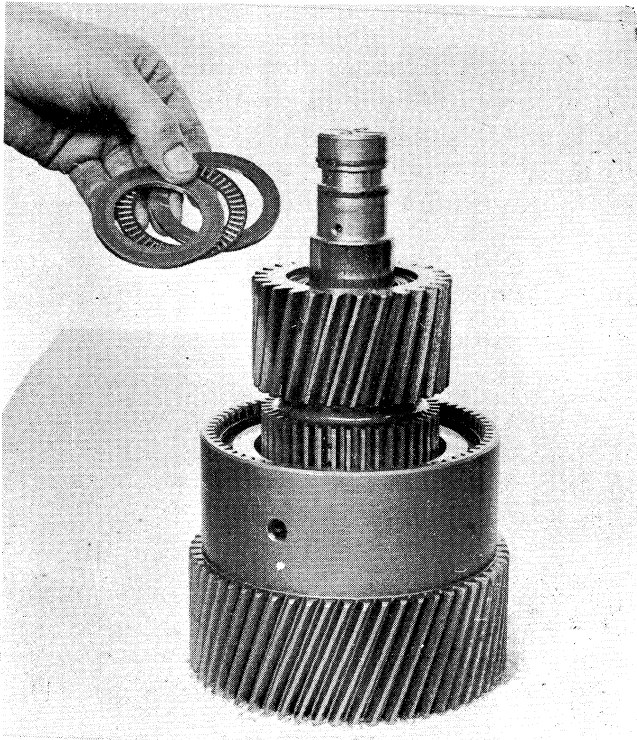

Fig. 21 . Removing the Rear Thrust Bearing, Spacer and Washer from the Forward Clutch Shaft.

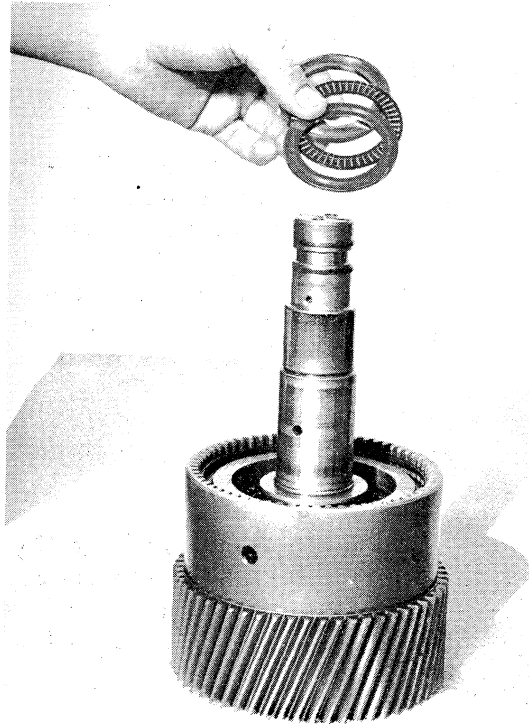

Fig. 22 . Removing the Front Thrust Bearing, Spacer and Washer from the Forward Clutch Shaft.

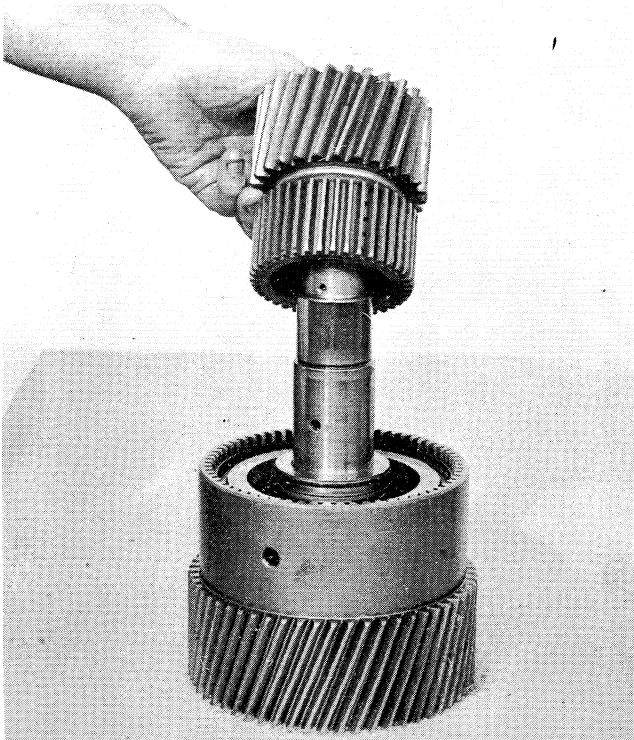

Fig. 23 . Removing the Clutch Hub and Pinion assembly.

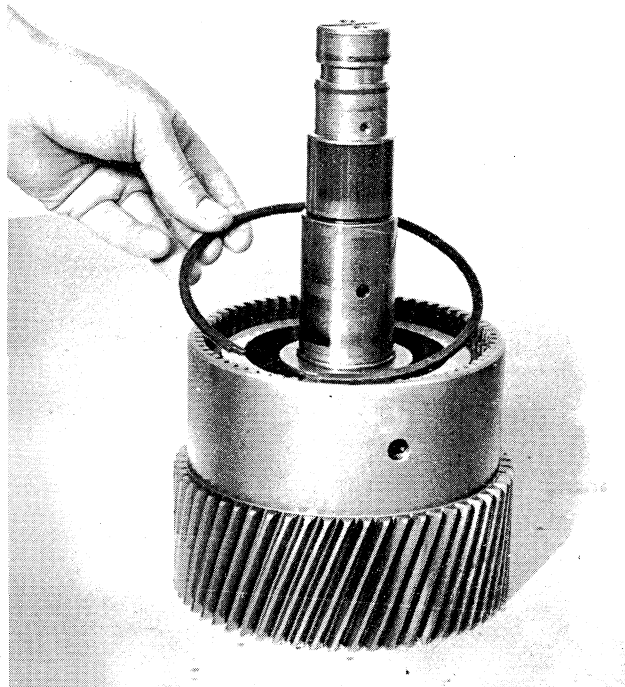

Fig. 24 . Removing the Internal Retaining Snap ring from the Housing Gear.

35. INPUT GROUP OF PARTS.

A. Release the tooth of the lock washer (fig. 63, 12) and remove the first lock nut (fig. 63, 13) using special tool TD 300351. Unscrew the second lock nut so that a clearance of 250 is obtained between the lock nut and the spider drive face. This is to prevent possible damage to parts or personal injury when the drive spider is released.

B. Carefully remove the drive spider from the input shaft using SKF Hydraulic press N° 226270. It is recommended to wrap teflon tape on both threads of the special tool to prevent grease or oil escaping during operation.

C. Remove the ten hex-head capscrews (fig. 62, 2) that secure the adaptor on the front half housing. Remove the adaptor from the front half housing. Remove the six hex-head capscrews (fig. 63, 9) that secure the bearing support (3) to the housing. Use two

M10 - x 1,5. pusher screws and remove the bearing support with attached parts, and the bearing support shims (4) from the housing. Remove the oil seal (8) from the bearing support. Discard the oil seal. Remove the bearing cup of the input shaft tapered roller bearing (5) from the bearing support *only if replacement of parts is necessary.*

D. Remove the input shaft group of parts from the main housing. Remove the bearing cup of the input shaft tapered roller bearing (fig. 63, 7) from the housing *only if replacement of parts is necessary.*

E. Remove the tapered roller bearings (fig. 63, 5, 7) using a bearing puller and a flat steel spacer to protect the shaft end. Use extreme caution when removing the bearing cone as the surface available on the cone for safe removal is very small and damage could destroy its serviceability. Extreme care must be taken to avoid damage on both tapered surfaces of the input shaft.

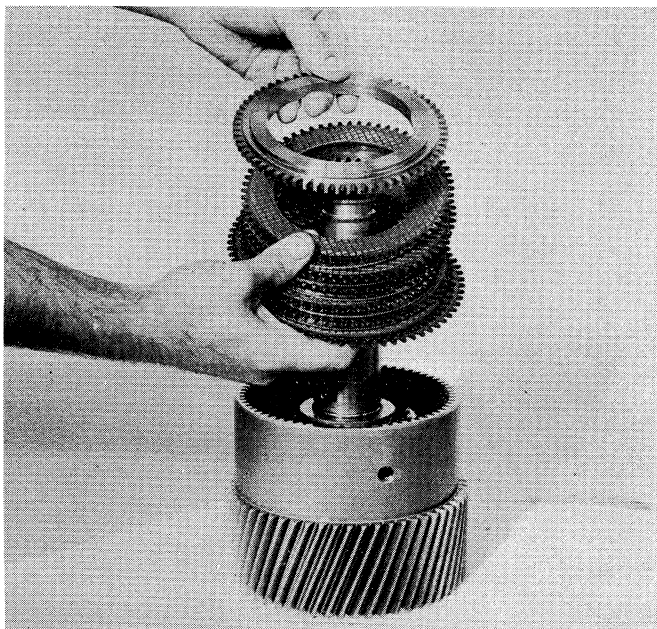

Fig. 25. Removing Clutch Plates and Back Plate from Forward Housing Gear.

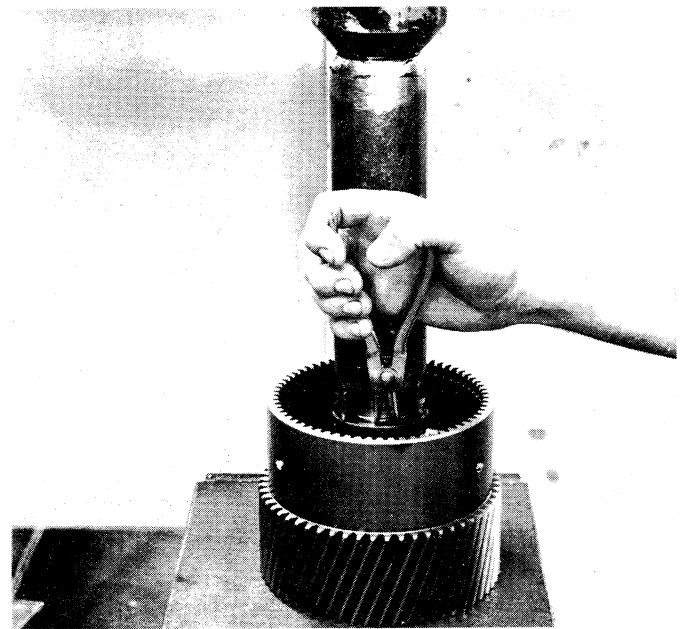

Fig. 26. Compressing Clutch Piston Return Spring and removing external Retaining Snap ring.

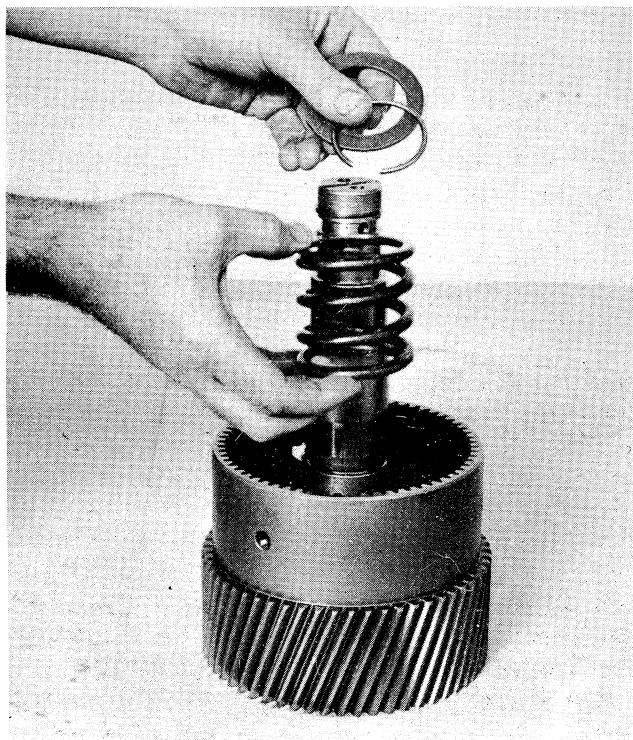

Fig. 27 . Removing clutch release spring and retaining parts.

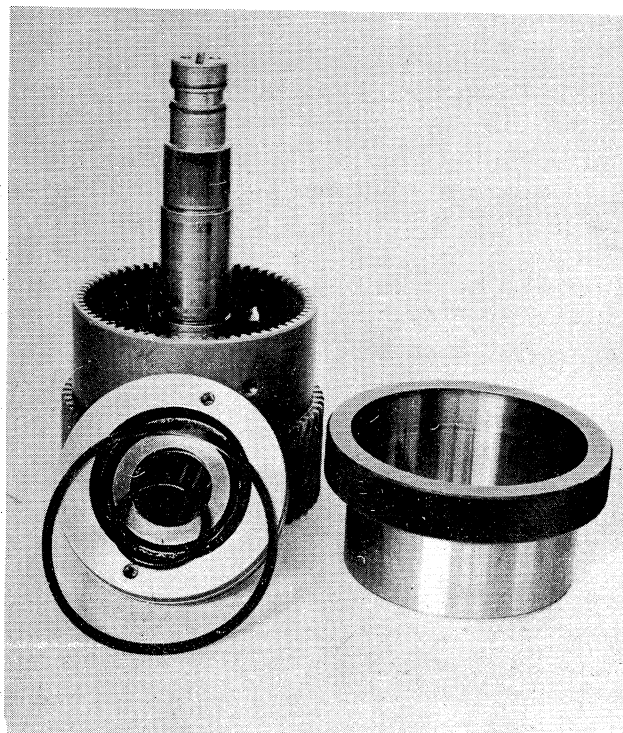

Fig. 28 . Special Tool to assemble and remove clutch piston assembly.

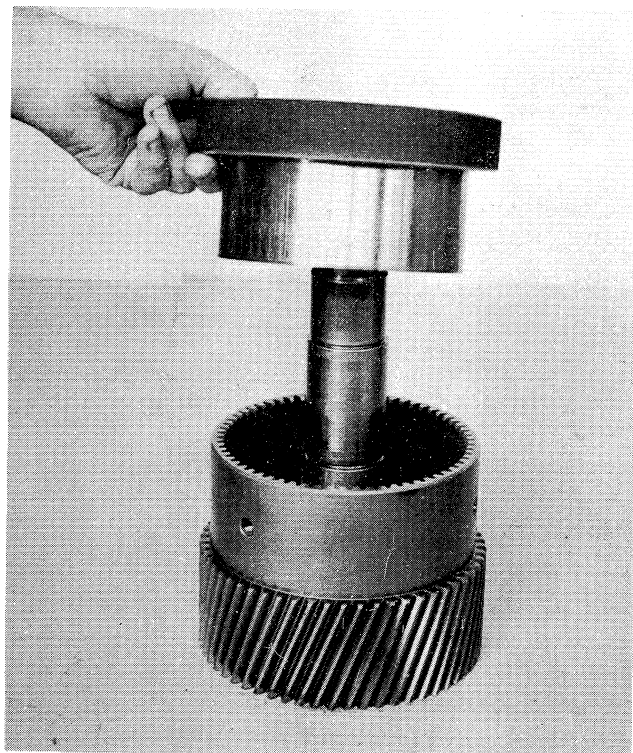

Fig. 29 . Installing of Special Tool.

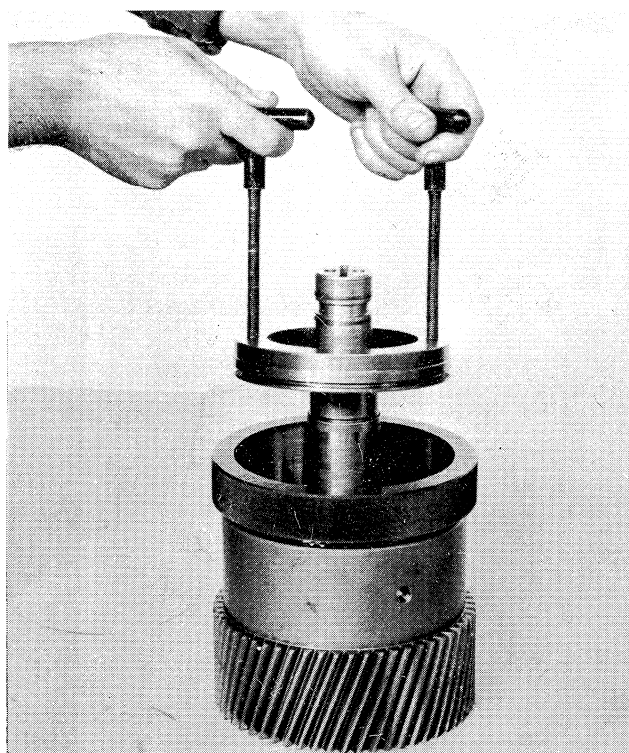

Fig. 30 . Removing clutch piston assembly using special tools.

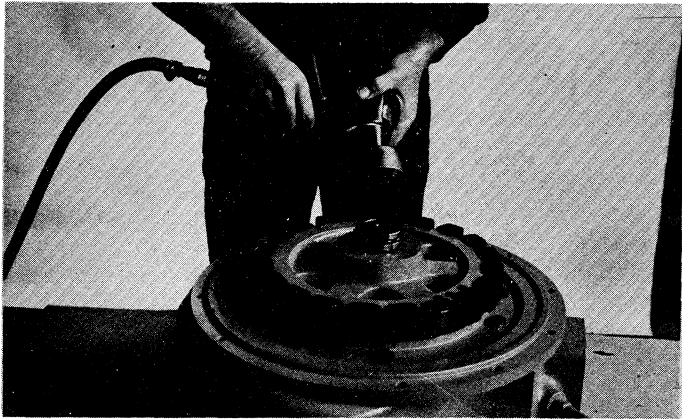

Fig. 31. Disassembly of Spider drive using Special Tool.

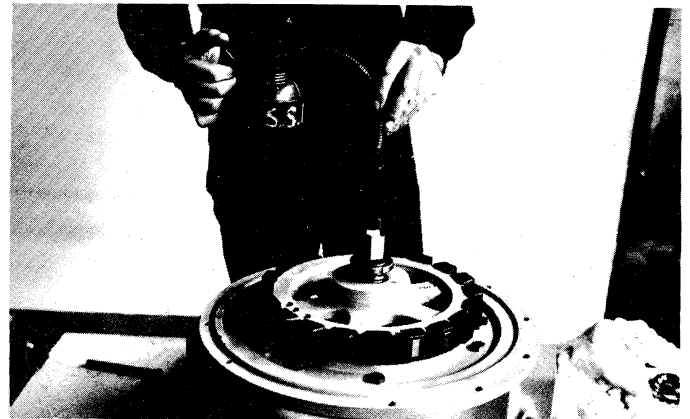

Fig. 32 - . Removing Input Drive Spider.

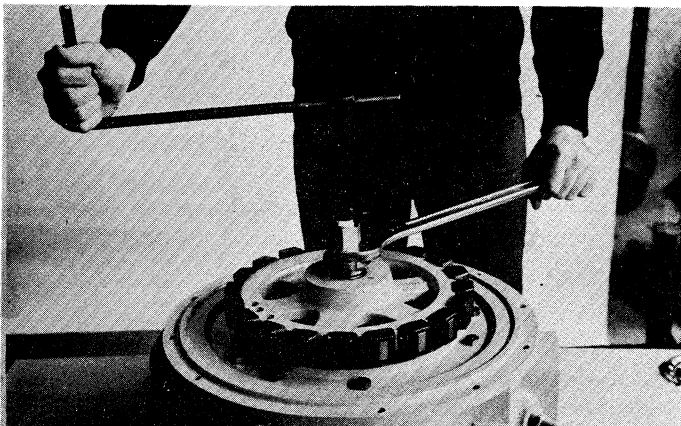

Fig. 32 - . Removing Input Drive Spider.

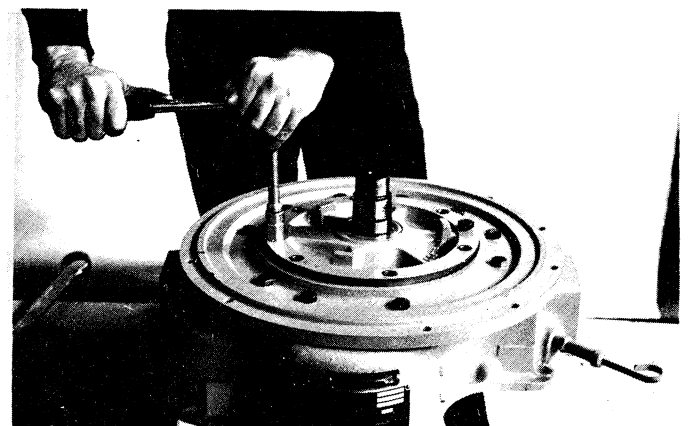

Fig.33 . Using Pusher Screws to remove Input Bearing support.

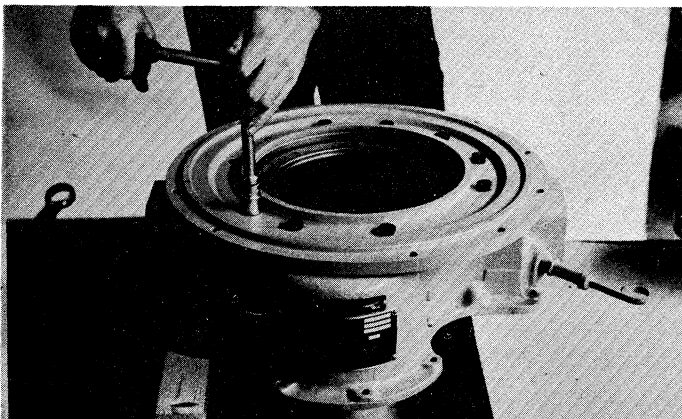

Fig. 34. Removal of front adaptor plate.

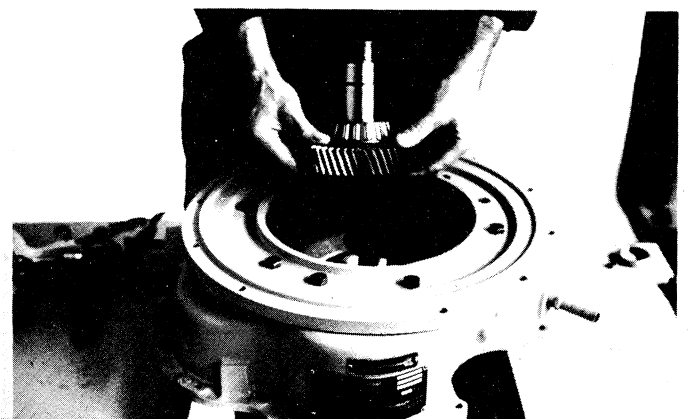

Fig. 35 . Removing the Input Shaft from main housing.



Section X. CLEANING AND INSPECTION

36. GENERAL.

- A. **Oil Seals.** Replace all oil seals.
- B. **Gaskets.** Replace all gaskets.
- C. **Piston Rings.** Replace all piston rings.
- D. **“O” Rings.** Replace all “O” rings.
- E. **Seal Ring.** Replace the seal ring.
- F. **Seal Washer.** Replace the seal washer.
- G. **Capscrew Locks.** Replace all capscrew locks.

37. CLEANING.

A. **Roller Bearings.** Use standard maintenance procedures to clean all roller bearings.

B. **Oil Pump Assembly.** Use fresh cleaning agent to flush the oil pump assembly.

C. **All Other Parts.** Thoroughly clean all other parts with a suitable cleaning agent. Examine each part after cleaning to make certain all foreign matter (including the “Loctite” plastic gasket material) has been removed. Be sure to remove the old “Loctite” plastic gasket from the surfaces right down to the original metal. After cleaning, dry with compressed air. Lubricate all machined surfaces with clean oil.

NOTE

Do not use any abrasive material on selector valve parts as damage will result.

38. INSPECTION.

A. **Roller Bearings.** Use standard maintenance procedures to inspect all roller bearings.

B. **Castings.** Inspect all castings for cracks. Replace a cracked casting. Inspect all bearing bores and mounting faces for wear, grooves, scratches, etc. Remove burrs and scratches with a crocus cloth.

Inspect tapped holes for damaged threads. Chase damaged threads with a thread tap of the correct size. Replace all castings that cannot be repaired. The front and rear half housings are a matched set and cannot be replaced separately.

C. **Splined Parts.** Inspect all splined parts for worn, twisted, chipped, or burred splines. If possible, remove these defects with a soft stone. Replace a splined part that cannot be rectified.

D. **Threaded Parts.** Inspect all threaded parts for damaged threads. Repair damaged threads with a thread file or a fine three-cornered file. Replace a threaded part that cannot be rectified.

E. **Pressure and Temperature Gauge Assemblies.** Inspect the pressure and temperature gauge assemblies for damage or inaccuracy. Replace a damaged or inaccurate gauge.

F. **Driving Ring.** Inspect the driving ring for damage or wear. Replace a damaged or worn ring.

G. **Drive Spider.** Inspect the drive spider for broken, cracked, or otherwise damaged lugs, spokes, or hub. Replace a damaged drive spider.

H. **Oil Tubes.** Inspect the oil tubes for damage. Replace a damaged oil tube. (Need special rolling tools.)

I. **Flexible Hose.** Inspect all flexible hoses for cracks, sponginess, or other damage. Replace a damaged hose.

J. **Gear Teeth.** Inspect all gear teeth for cleanliness and damage. Foreign particles tend to collect in the root of gear teeth. Clean thoroughly and repair minor damage with a fine file or crocus cloth. Replace a gear that cannot be rectified.

K. **Orifices and Passages.** It is very important that all orifices and passages be clean and clear. Use a small wire or a pipe stem cleaner to make certain the orifices and passages are clean and clear.

L. **Mounting Brackets.** Inspect the mounting brackets that support the marine transmission on the engine bed rails for cracks or other damage. Replace a damaged mounting bracket.

Section XI. ASSEMBLY

NOTES

1. *All torque ratings given are under dry conditions. New capscrews taken from bins or boxes, are not considered oiled. This does not include tapered conditions.*

2. *Assembly instructions for tapered joints. Surface preparation :*

a) *Observe that the parts fit well as determined by brightness of fit on the full length of taper, when previously assembled or by use of a very thin red lead compound, powder or equivalent to ensure full length of taper contact. Remove any rust scales, badly worm spots, nicks, ridges or projections by suitable means. DO NOT use chrome, copper, zinc, cadmium, lead, tin, silver, nickel and other coatings.*

b) *Clean the surfaces properly. After washing, remove all remaining traces of grease and oil from the tapered surfaces, using approved solvents, then air dry or dry with paper towels. When assembling the mating part prevent any oil, dust or other contaminant from falling upon the tapered surfaces.*

I,I,I-trichloroethylene (methyl chloroform) meeting OSHA requirements is a recommended solvent. The oil content in the solvent is to be limited to 10% maximum, by volume.

CAUTION

There is a possibility of clutch pack failure on initial start-up after rebuild, due to lack of lubrication until lube pressure builds up. All sintered metal clutch plates must be submerged in oil (use same oil as will be used in unit) for a minimum of one (1) hour prior to assembly. A longer soaking period would be even more beneficial. Covering the plates with oil from an oil can during assembly is NOT sufficient.

39. INPUT SHAFT GROUP OF PARTS

A. Place the bearing cones of the input shaft taper roller bearing (5 and 7) in ambient temperature oil or an oven. Heat to 275 degrees F. maximum to aid in the assembly of the cones. After the proper temperature has been attained, use an arbor press, and press the input shaft into the hot bearing cones of the input shaft tapered roller bearings (5 and 7). Make certain that bearing cones are installed against the shoulders on the input shaft.

B. Install the bearing cup of the input shaft tapered roller bearing (fig. 63, 7) in the bearing bore of the front housing (fig. 62, 8).

C. Install the bearing cup of the input shaft tapered roller bearing (fig. 63, 5) in the bearing bore of the bearing support (3).

D. After adjustment of the input shaft tapered roller bearings, per instruction n° 40 hereafter, remove the input package for assembly of the input spider (fig. 63) and SAE adaptor.

E. Fit on the front half housing the SAE adaptor (fig. 62, 4) which is secured by ten hex-head capscrews (fig. 62, 3).

F. Use special tool TD 300337, and install the bearing support oil seal (fig. 63, 8) in the bearing support. The lip of the oil seal must point toward the installed bearing cup in the bearing support.

G. Prepare the mating surfaces of the spider and input gear shaft per instructions above. Place the spider on the input shaft using special tool TD 300350 and advance the spider flush to within .000-.002 inch of shaft shoulder of small diameter end of taper.

If the special tool TD 300350 is not available, an alternative method of fitting the spider is as follow : Place the spider on the input shaft using 50-100 lbs max. force to seat it on the taper. Place the input package on an arbor press and advance the spider flush to within .000-.002 inch of shaft shoulder at small diameter end of taper.

A static press force of approximately 37.000 - 54.000 lbs. Will be required. A nominal advance of .0864 inch is expected and .0544 inch is the minimum acceptable advance. Fit the first lock nut (fig. 61, 11) and tighten it to 140 - 180 lbs ft. torque to secure the spider on the shaft. Fit the lock washer (fig. 63, 12) and the second lock nut (fig. 63, 12) and torque it to the same value to align the grooves of the lock nuts with one tooth of the lock washer. Then bend the tooth to secure the lock nut.

H. Install the complete input assembly on the front housing per instruction n° 41 hereafter.

40. ADJUSTING INPUT SHAFT END PLAY.

A. Alternative methods of adjusting input shaft end play are as described in the following paragraphs 40B and 40C. Select the method most practical for your equipment.

B. Place the input shaft group of parts in position in the front housing, and adjust for input shaft end play by the following procedure :

(1) Place the bearing support, with attached parts, in position over the input shaft and against the front housing. Retain the bearing support to the main housing with three M 10 x 1,5. hex-head capscrews (fig. 63, 9) installed just tight enough to remove all end play. Use feeler gauges, and measure the distance between the bearing support and the main housing at the points where the bearing support and the main housing at the points where the bearing support shims (4) will be installed. Add 0.003 inch to this measurement to determine the amount of shims required. Remove the bearing support from the main housing.

(2) Place the selected amount of bearing support shims determined above and the bearing support, with attached parts, in position against the housing. Secure the bearing support to the housing with six M 10 x 1,5 hex-head capscrews, (fig. 63, 9). Tighten the capscrews to 38 lbs.-ft. torque.

(3) Mount a dial indicator on the housing so that the plunger or stem of the indicator contacts the flat face of the drive spider; mark a spot adjacent to the indicator stem. Apply a pushing force to the drive spider of 60-180 lbs while rotating it through six 90 degree swings, setting the zero mark on the indicator while maintaining the pushing force. Apply a pulling force of 60-180 lbs on the spider and repeat the rotation or oscillation, stopping with the mark adjacent to the indicator stem. The indicator should read actual bearing end play while holding the pulling force on the shaft. End play must be between 0.003-0.005 inches. If it is not correct remove the capscrews (fig. 63, 9) that secure the bearing support (3) to the housing and correct the amount of bearing support shims (4) until proper end play adjustment is obtained.

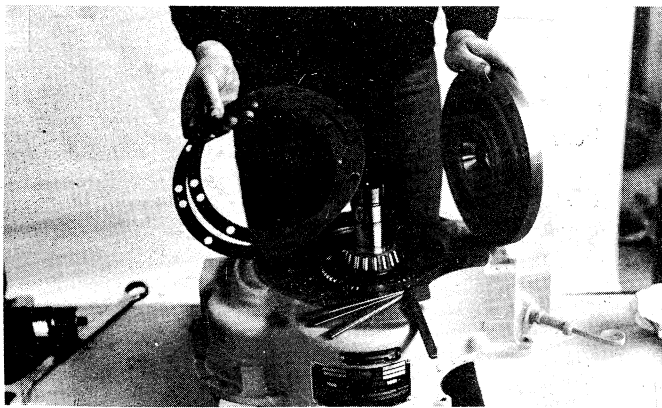

Fig. 36 Installing Shims and Input Bearing support.

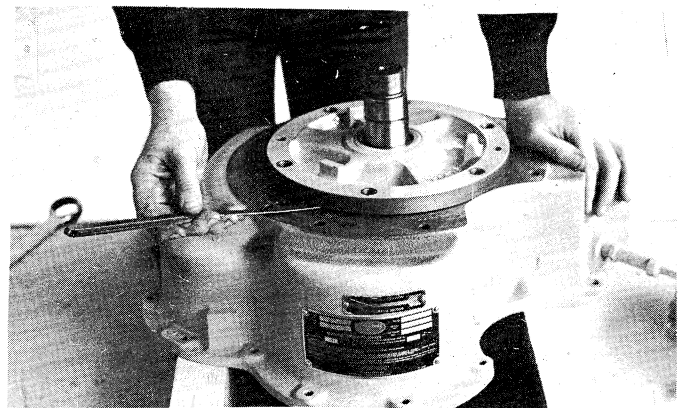

Fig. 37. Measuring Shim space between Support and housing.

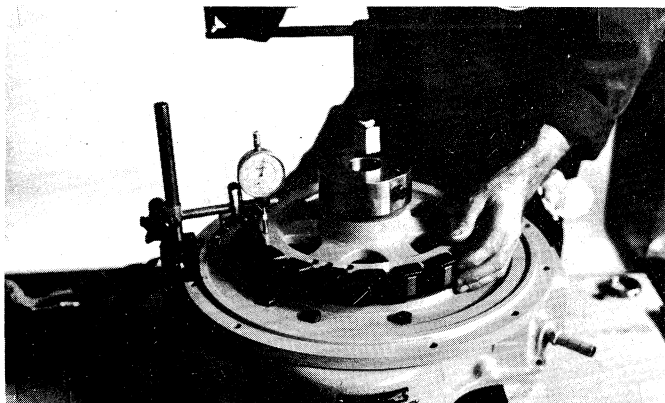

Fig. 38 Refitting of spider Drive.

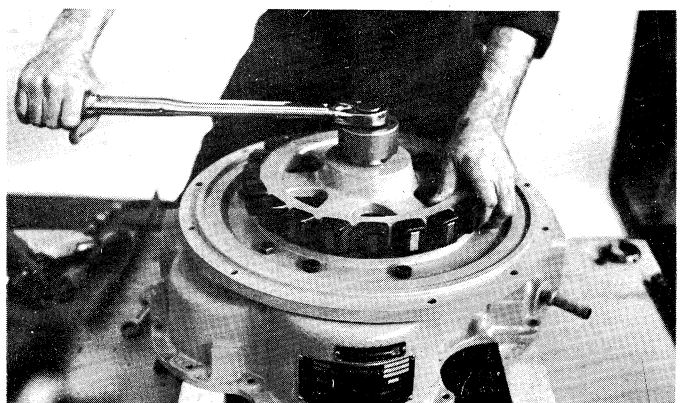

Fig. 39 Torque procedure using special tool T D 300351.

C. Place the input shaft group of parts in position in the housing, and adjust for input shaft end play by the following procedure :

(1) Use a caliper micrometer, and measure the thickness of the bearing support flange at a location adjacent to one of the pusher screw holes. Note this measurement.

(2) Place the bearing support, with attached parts, in position over the input shaft and against the housing. Retain the bearing support to the main housing with three **M 10 x 1,5.** hex-head capscrews (fig. 63, 9) installed finger tight to remove all end play. Use a depth micrometer, and measure the distance to the housing through a pusher screw hole. Determine the thickness of the bearing support shim pack by subtracting the thickness of the bearing support flange from the depth micrometer reading, and then adding 0.003-inch. Remove the bearing support from the housing.

(3) Place the selected amount of bearing support shims determined above and the bearing support, with attached parts, in position against the housing. Secure the bearing support to the main housing with six **M 10 x 1,5.** hex-head capscrews (fig. 63, 9). Tighten the capscrews to 38 lbs.-ft. torque.

(4) Use the same procedure for dial indicator checking of the bearing end play described in Paragraph 40B (3).

41. INSTALLATION OF INPUT SHAFT BEARING SUPPORT.

A. Place a continuous 1/8-inch to 1/4-inch wide ribbon of LOCTITE plastic gasket material at the point where the bearing support pilot diameter and the internal machined surface of the bearing support flange meet.

B. Place the input package in position against the housing. Secure the bearing support to the housing with six **M 10 x 1,5.** hex-head capscrews (fig. 63, 9). Tighten the capscrews to 38 lbs.-ft. torque.

C. The curing time for the LOCTITE plastic gasket material is approximately two hours.

42. FORWARD AND REVERSE CLUTCH GROUPS OF PARTS.

A. Place the front housing, with attached parts, in position with the output end up.

B. Install the bearing cup of the forward clutch shaft tapered roller bearing (fig. 64, 1) in the bearing bore of the main housing.

C. Install the bearing cup of the reverse clutch shaft tapered roller bearing (fig. 65, 1) in the bearing bore of the housing.

D. The assembly procedures for the forward and reverse clutch groups of parts are quite identical. The following procedure describes the assembly of the forward clutch group of parts, which contains an additional spacer (fig. 64, 26) between the bearing cup and the selector valve body flange.

(1) The housing gear and clutch shafts are service replaced as assemblies only. Use new housing gear and clutch shaft as required.

(2) Install a new pin if necessary using special tool TD 300344 which will position the pin at .620 - .660 inch from bottom face of clutch spider. Place the bearing cones to be used for assembly in a controlled temperature oven of 275° F.

(3) When the proper temperature has been attained for the bearing cones, place the *hot* bearing cone of the clutch shaft tapered roller bearing (fig. 64 , 1) in position on an arbor press, and press the clutch shaft into the *hot* bearing cone until the bearing cone is against the external hub of the housing gear.

(4) Place the clutch shaft, with attached parts, on a suitable surface with the front end down.

Install a new "O" ring seal (fig. 64, 8) in the inner groove of the clutch piston (1) and a new lathe-cut ring (fig. 64, 6) in the outer groove of the clutch piston. Carefully, install the clutch piston in the forward clutch housing gear using special tool TD 300323. Make sure that the hole in the clutch piston is in line with the antirotation dowel pin.

(5) Place the clutch piston spring (fig. 64, 13) in position over the clutch shaft and against the clutch piston. Place the external snap ring (15) and the retainer spring (fig. 64, 16) with its machined recess facing the snap ring in position on the clutch shaft, about 1/2 inch away from the clutch piston spring. Use special tool TD 300341 and compress the spring; the retainer and the snap ring together snaps into the groove machined in the clutch shaft. The installation of the snap ring will retain spring.

(6) Install the clutch plates (fig. 64 , 9 , 10) into the housing gear (2). Plates (faced) should have been soaking in an oil bath as specified in the caution note at the beginning of Section X I . Begin with a faced (sintered metal) plate (10) and alternately install a steel and faced plate to complete the plate stack of six steel and seven faced plates. Install the back plate (11) into the splined seat of the gear housing and secure the back plate in the housing gear with the internal snap ring (12).

(7) The clutch hub pinion assembly bushing is not supplied separately for service replacement. When a new bushing or pinion is required, an assembly consisting of the installed bushing and pinion is supplied.

(8) Install the thrust washer (fig. 64 , 16) thrust bearing (17), and thrust washer (18) over the clutch shaft and against the snap ring (15). Install the clutch hub pinion assembly (2021) into the clutch plate stack. You may have to pick up the clutch shaft with attached parts and, while holding the shaft with its input end up, shake and twist the parts as you install the pinion assembly, engaging the spline of the pinion with

the internal teeth of the steel clutch plates. With the pinion assembly installed, set the clutch shaft with attached parts on the bench input end down.

(9) Install the thrust race (fig. 64 , 22), the thrust needle bearing (23), and the thrust race (24) on the clutch shaft and against the clutch hub pinion.

(10) Use an arbor press, and press the *hot* bearing cone of the clutch shaft tapered roller bearing (fig. 64 , 25) on the clutch shaft and against the installed thrust race (24).

43. OUTPUT SHAFT GROUP OF PARTS.

A. Place the bearing cones of the output shaft tapered roller bearings (fig. 63 , 15 & 18) in ambient temperature oil or oven. Heat the oil or oven to 275 degrees Fahrenheit to aid in assembly of the cones.

B. After the proper temperature of the bearing cones has been attained, place the hot bearing cone of the output shaft tapered roller bearing (fig. 63 , 15) on an arbor press. Press the output shaft (16) into the hot bearing cone, and against the shoulder on the shaft.

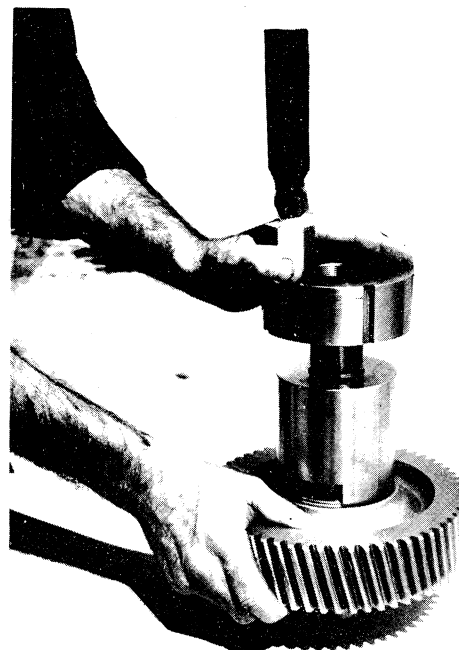

Fig. 40 Reassembly of the gear on the output Shaft using special tool T D 300 350.

C. Prepare the tapered surfaces of the output shaft (fig. 63, 16) and gear (fig. 63, 17) per instruction (Section XI, note 2). Install the output gear on the taper of the shaft after fitting the special tool TD 300350 in place of the retainer screw (fig. 63, 25). Fit the sleeve against the output gear and then the piston with the hydraulic press S.K.F. 226.270 Press the gear flush within .000 - .002 inch of shaft shoulder at small diameter end of taper.

NOTE

The sleeve have been designed with a slot to permit visual inspection of the flush condition of the gear.

If the special tool TD 300350 is not available, an alternative method of fitting the gear is as follow : Place the gear on shaft using 100 to 200 lbs. max.

force to seat it on its taper advance the gear to within .000 - .002 inch of the shoulder at small diameter end of taper. Astatic press force of approximately 57000 - 90000 lbs will be required.

A nominal advance of .078 inch is expected and .061 inch is the minimum acceptable advance.

D. Place the *hot* bearing cone of the output shaft tapered roller bearing (fig. 63 ,18) on two steel bars placed over a cut out surface on an arbor press. Press the output shaft, with attached parts, into the bearing cone until the output gear hub surface makes contact with the bearing cone.

E. Install the oil shield (fig. 63 ,14) and the bearing cup of the output shaft tapered roller bearing (fig. 63,15) in the front half housing.

F. Place the forward clutch group of parts, the reverse clutch group of parts, and the output group of parts in their respective positions in the main housing.

G. Degrease both faces of front and rear half housings and apply anaerobic plastic gasket compound. Place the rear half housing (fig. 62, 9) in position on the dowel pins (fig. 62, 3) and against the front half housing. Secure the housings with seventeen hex-head capscrew (71) (M10 x 1,5 x 30) tighten the capscrews to 34 lbs.ft torque.

44. ADJUSTING CLUTCH SHAFT BEARING END PLAY.

A. Install the bearing cup of the clutch shaft tapered roller bearing (fig.64 , 25) and the spacer (26) in the rear housing over the forward clutch shaft location. Install the spacer (fig. 26) over the forward clutch shaft location. Install the bearing cup of the clutch shaft tapered roller bearing (fig. 65 , 25) in the rear housing over the reverse clutch shaft location.

B. Alternative methods of adjusting clutch shaft end play are possible as described in the following paragraphs 44D and 44E. Select the method most practical for your equipment. A dial indicator must be used as the final check for bearing end play.

C. The alternative methods for adjusting the end play in the reverse clutch group of parts are described in the following sub-paragraphs (1) and (2).

(1) Place the pump mount (fig. 62, 44) in position against the rear housing with three hex-head capscrews (43) M 10 x 1,5. Tighten the capscrews until all end play is removed from the clutch shaft. Use feeler gauges, and measure the distance between the cover and pump mount. Note this measurement and add 0.003 inch. This total should establish a proper clutch shaft bearing end play between 0.003 and 0.005 inch. Remove the pump mount from the rear cover. Place the selected amount of pump mount shims (39) and the pump mount in position against the rear cover. Secure the pump mount to the rear cover with the capscrews previously removed. Tighten the capscrews to 4,7 mkg (38 lbs. ft. torque). Fit an eyebolt with at least a 5 inch stem to the 5/16 inch threaded hole in the end of the output shaft. Mount a dial indicator so the stem or plunger contacts the end of the clutch shaft exposed in the pump mount opening. Mark a spot adjacent to the indicator stem and apply a pushing force to the end of the clutch shaft with approximately 80 - 240 lbs. With this force applied, turn the shaft through two complete revolutions or six oscillations of 90 degree swings to seat and align the tapered roller bearings at input end of the shaft. Stop the shaft with the mark adjacent to the indicator stem and with force still applied, zero the indicator. Apply a pulling force of 80 - 240 lbs. with a hoist on the eyebolt, and rotate the shaft through

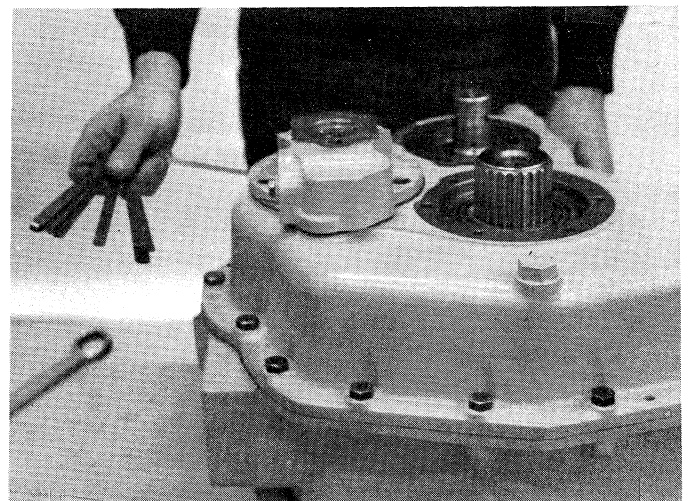

Fig. 41 . Measuring Shim space between Pump mount and the Rear Cover.

two complete revolutions, or six oscillations of 90 degree swings to seat and align the rear tapered roller bearings. Stop the shaft with the mark adjacent to the indicator stem and with force still applied read the actual bearing end play on the indicator. End play must be between 0.003 and 0.005 inch. If this end play is not established it will be necessary to remove the capscrews that secure the pump mount to the rear half housing and correct the amount of pump mount shims for proper end play adjustment. In any case, it will be necessary to remove the pump mount for final installation as described in Paragraph 46.

(2) Use a depth micrometer, and measure the distance between the machined shim surface on the pump mount (fig. 62, 44) and the surface on the pump mount pilot that will contact the bearing cup in the rear housing. Note this measurement. Make certain the bearing cup has been installed in the rear housing so that it contacts the taper roller bearing and all end play is removed. Use a depth micrometer, and measure the distance between the machined shim surface on the rear housing and the bearing cup. Subtract this measurement from the measurement previously noted. Add 0.003 inch to this number.

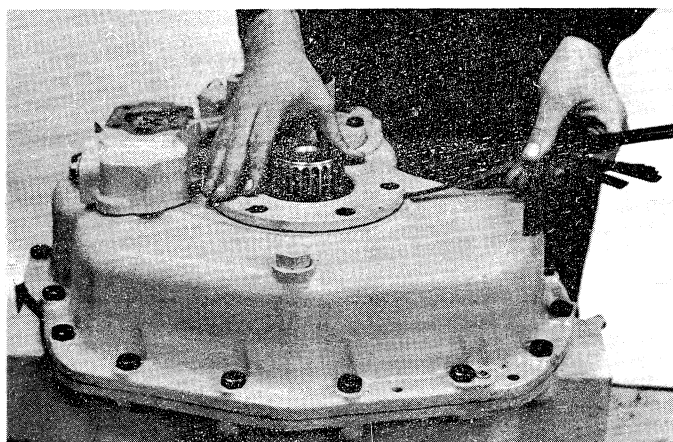

Fig. 42 . Measuring Shim space between Output Bearing Retainer and Rear Housing.

This new total should establish a proper clutch shaft end play between 0.003 and 0.005 inch. Place the selected amount of pump mount shims (62, 39) just determined and the pump mount in position against the rear housing. Secure the pump mount to the rear housing with three M 10 x 1,5. hex-head capscrews

(62, 43). Tighten the capscrews to 34 lbs. ft. torque. Mount a dial indicator on the rear housing so that the plunger of the indicator contacts the end of the clutch shaft exposed in the pump mount opening. Use the same procedures outlined in paragraph (1) above to check end play with the dial indicator. After adjustment of end play, remove the pump mount to make final installations as covered in paragraph 46

E. Use the same procedures for adjusting and checking clutch shaft bearing end play of the forward clutch shaft as those described above in paragraph D. The only difference is that the selector (regulator) valve assembly body (fig. 62, 30) replaces the pump mount referred to in the procedures used for the forward clutch shaft location.

45. ADJUSTING OUTPUT SHAFT END PLAY.

A. Alternative methods for adjusting the end play in the output shaft group of parts are possible as described in the following paragraphs B and C. Select the method most practical for your equipment.

B. Place the bearing retainer (fig. 63, 20) in position against the rear housing and retain the bearing retainer to the rear housing with six finger tight M 10 x 1,5. hex-head capscrews (27). Place the output flange (22) in position on the output shaft. Secure the output flange on the output shaft with the retainer washer (24) and the 7/8-9 x 3 hex-head capscrew (25). Tighten the capscrew to 450-405 lbs. ft. torque. Tighten the capscrews holding the bearing retainer to the rear housing until all end play is removed from the output shaft. Use feeler gauges, and measure the distance between the bearing retainer and the rear housing. Note this measurement. Add 0.003 inch to the measurement in order to determine the amount of bearing retainer shims (19) required. Remove the capscrew, retainer washer, and output flange from the output shaft. Remove the capscrews and the bearing retainer from the rear housing. Place the selected amount of bearing retainer shims (19), just determined, and the bearing retainer in position against the rear housing. Secure the bearing retainer to the rear housing with three capscrews previously removed. Tighten the capscrews to 34 lbs. ft. torque. Install the output flange, retainer washer, and capscrew on the output flange. Tighten the capscrew



Fig. 43. Applying pulling force while checking end play of Input Shaft with dial indicator.

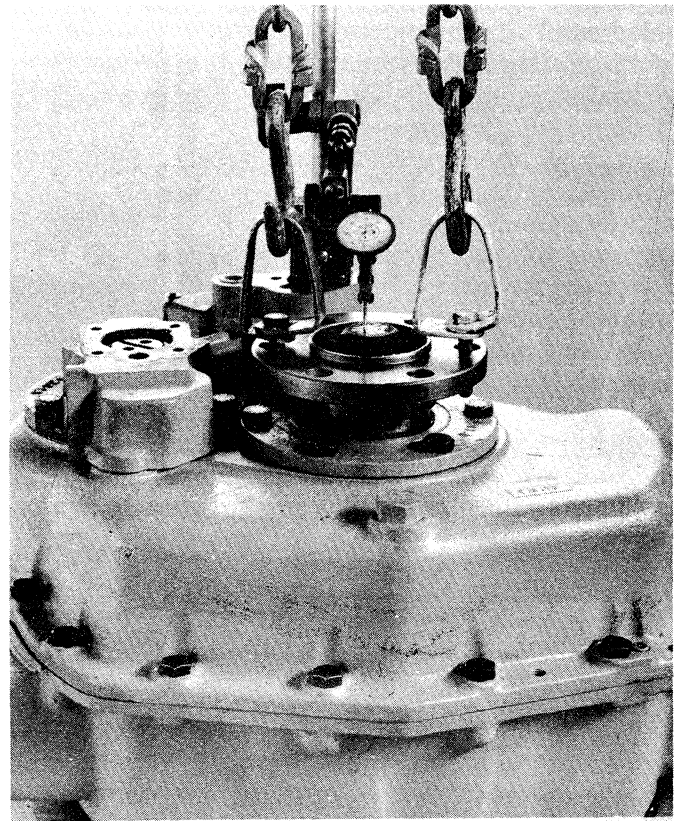

Fig. 44. Applying pulling force while checking the Output Shaft end play.

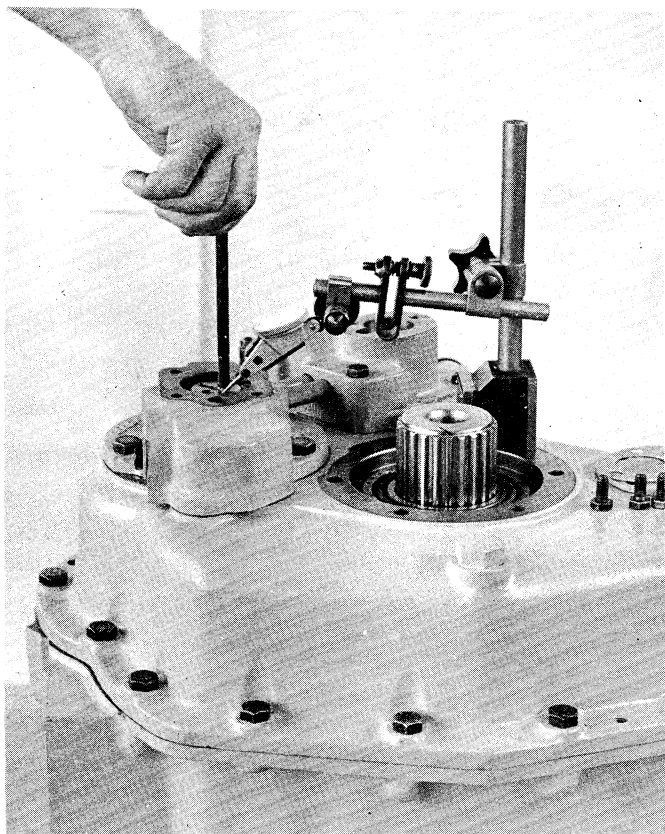

Fig. 45. Applying pushing force while checking Reverse Clutch Shaft end play.

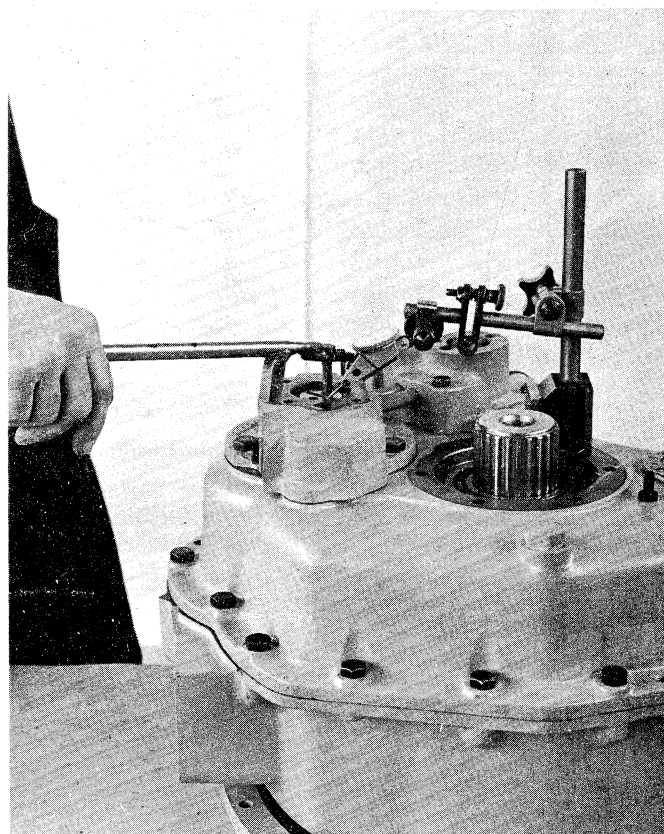

Fig. 46. Applying pulling force while checking Reverse Clutch Shaft end play.

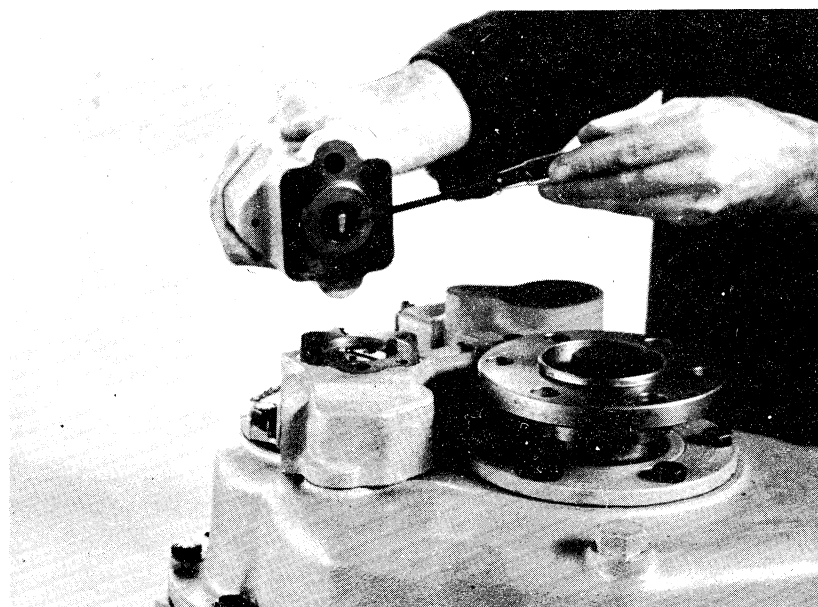

Fig. 47. Installing Oil pump with care to align drive tang.

to 450-405 lbs. ft. torque. Mount a dial indicator, so the stem contacts the smooth area on the flange. Mark a spot adjacent to the indicator stem. Rotate the flange and shaft with a force (pushing) of approximately 150-450 lbs. Rotate through two complete revolutions or six oscillations of 90 degree swings, to seat and align the output shaft front tapered roller bearing. Stop with mark adjacent to indicator stem, and while still applying pushing force, zero the dial indicator. Attach a hoist and scale to the output flange (22). Apply a pulling force of 150-450 lbs. to the output shaft and flange while rotating the shaft through two complete revolutions, or six oscillations of 90 degree swings to seat and align the rear output shaft tapered roller bearing. Stop at the mark adjacent to the indicator stem and while still applying the pulling force read the actual bearing end play. Note end play reading on indicator. End play *must be* between 0.003 and 0.005 inch. If this end play range is not attained, it will be necessary to remove the output flange and bearing retainer and correct the amount of bearing retainer shims for proper end play adjustment. In any case, it will be necessary to remove the flange and retainer to make final installation as described in paragraph B.

C. Use a depth micrometer, and measure the distance between the machined shim surface on the bearing retainer (fig. 63, 20) and the surface on the bearing retainer that will contact the bearing cup in the rear housing. Note this measurement. Make certain the bearing cup has been installed in the rear housing so that it contacts the taper roller bearing and all end play is removed. Use a depth micrometer, and measure the distance between the machined shim surface on the rear housing and the bearing cup. Subtract this measurement from the measurement previously noted. Add 0.003 inch to this number. This new total should establish a proper output shaft end play between 0.003 and 0.005 inch. Place the selected amount of bearing retainer shims (19), just determined, and the bearing retainer in position against the rear housing. Retain the bearing retainer to the rear housing with six M 10 x 1.5. hex-head capscrews (27). Tighten the capscrews to 34 lbs. ft. torque. Place the output flange (22) in position on the output shaft. Secure the output flange on the output shaft with the retainer washer (24) and the 7/8-9 x 3 hex-head capscrew (25). Tighten the capscrew to 450-405 lbs. ft. torque. Tighten the capscrews (27) that retain the bearing retainer

to the rear housing to 34 lbs. ft. torque. Mount a dial indicator on the rear housing so that the stem of the indicator contacts the smooth area on the flange. Use the same checking and adjusting dial indicator procedures described in paragraph B above. End play *must be* between 0.003 and 0.005 inch. If this end play is not attained, it will be necessary to remove the output flange and bearing retainer to correct the amount of bearing retainer shims for proper end play adjustment. In any case, it will be necessary to remove the flange and retainer to make a final installation as described in paragraph B.

46. FINAL INSTALLATION.

A. The following procedure describes final installation for the pump mount and selector valve assembly.

(1) After final amount of pump mount shims have been determined for proper end play, remove the pump mount from the rear housing.

(2) Place the pump mount shims (fig. 62,39) and "O" ring (52) in position against the rear housing.

(3) Place a continuous 1/8-inch to 1/4-inch wide ribbon of LOCTITE plastic gasket material at the point where the pump mount pilot diameter and the internal machined surface of the pump mount flange meet.

(4) Install the "O" ring seal (fig. 62, 23) into its groove in the selector valve spool (24). Prelubricate the spool, seal, and valve bore in the valve body (30).

(5) **Procedure for selector valve assembly :** Install the shims, inner and outer springs (fig. 62, 27, 26, 35) into the valve bore of the valve body.

Install the pressure regulating valve (fig. 62, 25) into the hole in the end of the selector valve spool and insert this assembly into the valve bore of the valve body.

Install the detent plate (21) in position on the valve body. Attach the plate with two hex-head capscrews (17) securing the valve spool in the body. Tighten the screws (17/5/16 - 18 x 3/4) to 21 lbs. ft. torque.

(5) **A. Procedure for selector valve and main regulator valve with pressure rate of rise control :**



Install the pressure regulating valve (fig. 62, 55) into the hole in the end of the selector valve spool and insert this assembly into the valve bore of the valve body.

Install the shims, inner and outer springs (fig. 62, 54, 55) into the pressure rise piston (56) and insert this assembly into the valve bore of the valve body. Install the "O" ring seal (fig. 62, 50) on the pressure rise plug (51) and insert this assembly at the end of the bore by fitting the snap ring (52). Install the detent plate (30) in position on the valve body. Attach the plate with two hex-head capscrews (22) securing the valve spool in the body.

Tighten the screws (22/5/16-18 x 3/4) to 21 lbs. ft. torque. Install the "O" ring (fig. 62, 40) on the seat shuttle valve (39). Install the ball (41) in the hole at the end of the seat shuttle valve (39).

Prelubricate the bore and the "O" ring. Insert this assembly in the bore of the valve cover (43). Install the "O" ring (38) on the plug (37) and screw the plug in the thread hole of the valve cover. Place the valve cover gasket (fig. 62, 36) on the selector valve body. Secure the valve cover (43) on the valve body (34) with three hex-head capscrews (42, 47, 48). Tighten the screw (5/16 - 18 x 3/4) to 21 lbs. ft torque.

(6) Install the four "O" ring seals (fig. 62, and 17) into the connecting tubes (18) and install the tubes into their holes in the pump mount (61) and selector valve body (34) after prelubricating the seals and bores.

(7) Place the regulator valve body shims (fig. 62, 36) in position against the rear housing. Place a continuous 1/8-inch to 1/4-inch wide ribbon of LOCTITE plastic gasket material at the area where the valve body pilot diameter and internal machined surface of the valve body flange meet.

(8) Position the shift lever (fig. 62, 19) on the

valve spool and secure it with the clamp screw (18) (1/4-20 x 1) and nut (20). Tighten the clamp screw to 11 lbs. ft. torque. Install pipe plug (28) in the valve body.

(9) Simultaneously, place the pump mount and valve assembly into the rear housing with connecting tubes installed. Use care in sliding the mount and valve assembly over the clutch shaft seal rings.

(10) Secure the selector/regulator valve assembly to the rear housing with one hex-head capscrew (fig. 62, 34) (M 10 x 1,5) and two hex-head capscrews (33) (M 10 x 1,5). Tighten the capscrews to 34 lbs. ft. torque.

(11) Secure the pump mount to the rear housing with three hex-head capscrews (fig. 62, 43) (M 10 x 1,5). Tighten the capscrews to 34 lbs. ft. torque.

(12) Install the filter screen

B. The following procedure describes final installation for the output group of parts :

(1) After final amount of bearing retainer shims have been determined for proper end play, remove the output flange from the output shaft and the bearing retainer from the rear housing.

(2) Use special tool TD 300339 and an arbor press, and press a new bearing retainer oil seal (fig. 63, 21) in the bearing retainer.

(3) Place a continuous 1/8-inch to 1/4-inch wide ribbon of LOCTITE plastic gasket material at the point where the bearing retainer pilot diameter and the internal machined surface of the bearing retainer flange meet.

(4) Place the bearing retainer shims and the bearing retainer in position against the rear housing. Secure the bearing retainer to the rear housing with six M 10 x 1,5 x 25 hex-head capscrews (fig. 63, 27). Tighten the capscrews to 34 lbs. ft. torque.

(5) Place the output flange in position on the output shaft. Using a depth micrometer, measure the distance between the end face of the shaft and the contact surface of the retainer washer (fig. 63, 23) on the output flange; subtract 0.003 inch to 0.006 inch from this number. This new total should establish the amount of shims (fig. 63, 26) for the correct tension of the retainer washer. Secure the output flange on the output shaft with a new lathe-cut rubber seal ring (fig. 63, 23), the retainer washer (25), and the 7/8-9 x 3 hex-head capscrew (25). Tighten the capscrew to 450-405 lbs. ft. torque.

47. MISCELLANEOUS EXTERNAL PARTS.

A. Place the oil pump assembly and a new oil pump gasket (fig. 62, 40 and 42) in position against the pump mount (44). Align the driven shaft of the oil pump assembly in the slot of the reverse clutch shaft.

CAUTION

Make sure the pump drive tang engages the slot of the clutch shaft. This will

prevent possible damage from occurring to the pump and Marine Gear.

Secure the oil pump assembly to the pump mount cover with four (M 8 x 1,25 x 110) hex-head capscrews (41). Tighten the capscrews to 18 lbs. ft. torque.

B. Install the drain plug (fig. 62, 50) and a new "O" ring (fig. 62, 51) in the bottom of the rear housing. Tighten the plug securely. Install alternate oil gauge plug (1) into the housing (8) if removed.

C. If removal has been necessary, place a new engine rotation indicator plate (fig. 62, 14) in position against the adaptor plate. Secure the plate to the housing with two new drive screws (13).

D. If removal has been necessary, place a new name plate (fig. 62, 6) in position against the front housing. Secure the plate to the housing with four drive screws (5). Make certain the data stamped on the old name plate is transferred to the new name plate.

E. If removal has been necessary, install a new breather cap assembly (fig. 62, 16) in the rear housing.

F. Install the oil level gauge tube (fig. 62, 10) in the housing. Install the oil level gauge (11) in the oil level gauge tube.



Fig. 48 Measuring Shim space between output shaft and retainer face of the flange.

Section XII. INSTALLATION

48. PRIOR TO INSTALLATION.

A. General. The marine transmission flange and pilot, and the engine flywheel and flywheel housing must be checked for trueness. Make certain the engine flywheel and flywheel housing are clean prior to making the tests. Make sure the crankshaft is moved to zero end play while making all face checks.

B. Checking Marine Transmission Flange. Bolt a dial indicator graduated in thousandths inches to the drive spider of the marine transmission so that the indicator is perpendicular to the face of the marine transmission housing, and the indicator stem is riding on the face of the flange. Rotate the drive spider and note the face runout of the marine transmission flange. The face runout must not exceed 0.010 inch maximum total indicator reading for the SAE No. 3 flange, or a 0.010 inch maximum total indicator reading for the SAE No. 2 flange, or a 0.012 inch maximum total indicator reading for the SAE No. 1 adapter ring.

C. Checking Marine Transmission Pilot Ring. With the indicator mounted as in Paragraph B above, adjust the indicator stem so that it will ride on the pilot surface of the flange. Rotate the drive spider and note the pilot surface runout of the flange. The pilot surface runout must not exceed 0.008 inch for the SAE No. 3 flange, or 0.008 inch for the SAE No. 2 flange, or 0.008 inch for the SAE No. 1 adapter ring. This applies to a continuous 270 degree arc if the balance of the pilot surface is negative in reading; otherwise, it means all 360 degrees.

D. Checking Face of Engine Flywheel Housing. Bolt a dial indicator graduated in thousandths inches to the engine flywheel so that the indicator is perpendicular to the face of the engine flywheel housing, and the indicator stem is riding on the face of the flange (fig. 49). Rotate the engine flywheel and note the face

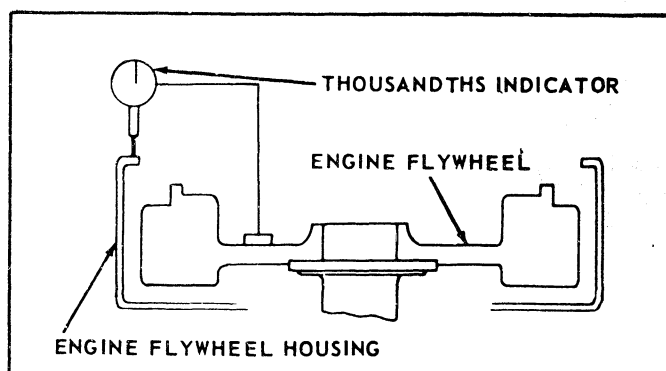

Figure 49. Checking the face of the engine Flywheel Housing.

deviation of the engine flywheel housing flange. The face deviation must not exceed 0.008-inch maximum total indicator reading.

E. Checking Bore of Engine Flywheel Housing. With the indicator mounted as in Paragraph D above, adjust the indicator stem so that it will ride on the bore of the engine flywheel housing (fig. 50). Rotate the engine flywheel and note the eccentricity of the engine flywheel housing bore. The bore eccentricity must not exceed 0.008-inch maximum total indicator reading.

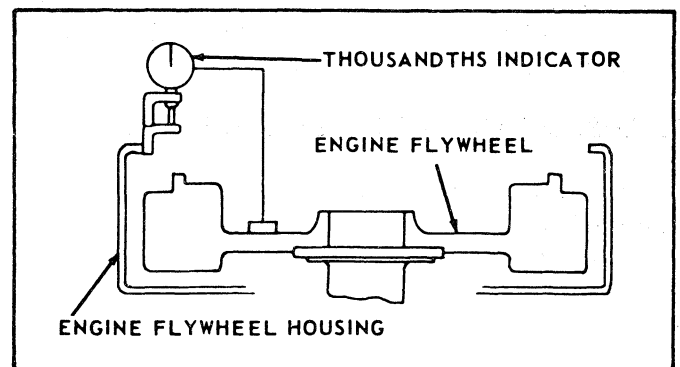

Figure 50. Checking the bore of the engine Flywheel Housing.

F. Checking Driving Ring Surface of Engine Flywheel. Bolt a dial indicator graduated in thousandths inches to the engine flywheel housing so that the indicator is perpendicular to the engine flywheel, and the indicator stem is riding on the inner face of the flywheel (fig. 51). The variation of the face runout of the surface to which the driving ring is bolted should not exceed 0.0005-inch maximum total indicator reading per inch of diameter.

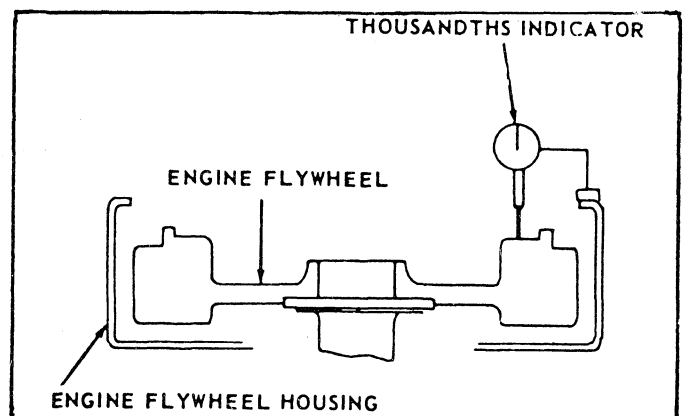

Figure 51. Checking the Driving ring surface of the engine Flywheel Housing.

G. Checking Driving Ring Pilot Bore of Engine Flywheel. With the indicator mounted as in Paragraph F above, adjust the indicator stem so that it will ride on the driving ring pilot bore of the engine flywheel (fig. 52). The driving ring pilot bore eccentricity of the engine flywheel should not exceed 0.005-inch maximum total indicator reading.

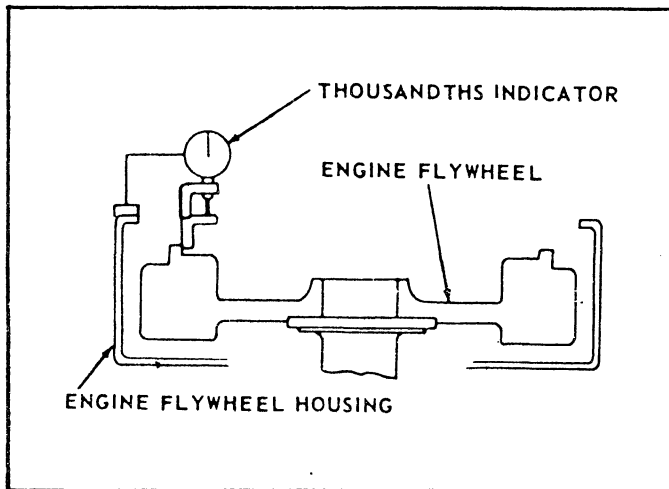

Figure 52. Checking the Driving ring pilot bore of the engine Flywheel Housing.

49. INSTALLATION.

(See page 52 for alignment of propeller shaft mating flange.)

A. General. The alignment of the marine transmission with the engine is an extremely important factor in obtaining lengthy, trouble-free performance from the marine transmission. An extra few minutes of time for an accurate and proper installation will be returned many times in avoiding unnecessary future downtime.

B. Alignment. Install the mounting brackets on the side mounting pads of the marine transmission.

Install the driving ring on the engine flywheel with the fasteners previously removed. Bolt an indicator to the engine block and set the indicator stem on the engine flywheel housing. Set the indicator gauge at zero (0). Lift the marine transmission with a hoist, or other suitable means, and place the unit in position against the engine flywheel housing. Guide the rubber blocks on the drive spider into the driving ring. Secure the flange of the marine transmission housing to the engine flywheel housing with twelve (3/8-16 x 1) hex-head capscrews. Tighten the capscrews to 38 lbs.-ft. torque. Use a feeler gauge between each mounting bracket and engine bedrail. Add shims between the brackets and bedrails to equal the feeler gauge readings. Carefully release the lifting force on the marine transmission. The indicator gauge must remain steady at the zero mark. Torque bed bolts to proper rating. If the reading moves from zero, lift the marine transmission and insert additional shims. Continue this procedure until the marine transmission is completely at rest on the bedrails and the gauge maintains a steady zero reading. After obtaining the correct zero reading, secure the mounting brackets to the engine bedrails. Before securing the mounting brackets to the engine bedrails, the propeller shaft should be checked for alignment. See text on alignment, beginning on page 52.

C. Output Flange Connection. Slide the propeller shaft and the companion flange forward against the output flange. Align the scribed marks on the companion flange and the output flange. Secure the flanges together with the bolts and nuts previously removed.

D. Connecting Linkage. Connect all linkage and lines previously disconnected from the marine transmission.

E. Hydraulic System. Fill the hydraulic system with the proper type, weight, and amount of oil as specified in Paragraph 2.

Section XIII. SPECIAL TOOLS

Section XIV. PARTS LIST

50. SPECIAL TOOLS.

Figures 52 through 59 in this section identify the special tools by tool number. All pertinent information necessary for tool fabrication is shown on each tool drawing. Twin Disc, will not manufacture, for general use, the tools illustrated in this manual.

51. PARTS LIST.

Use Figures (62) through (65) and the adjacent parts list for ordering spare or replacement parts in accordance with the instructions contained in Section I Paragraph 3 . Following the parts lists are planographs of the MG-507 Marine Transmission.

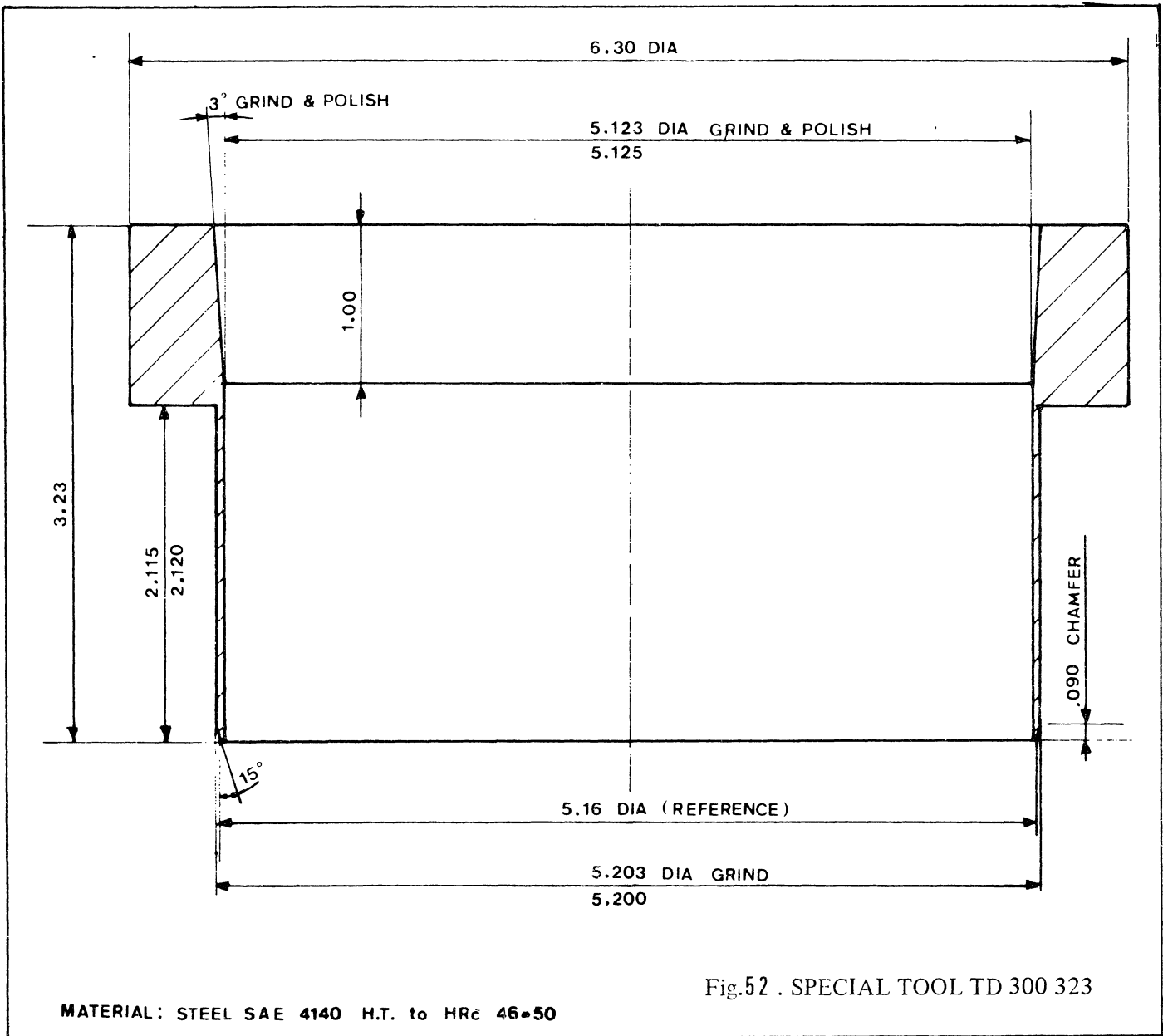
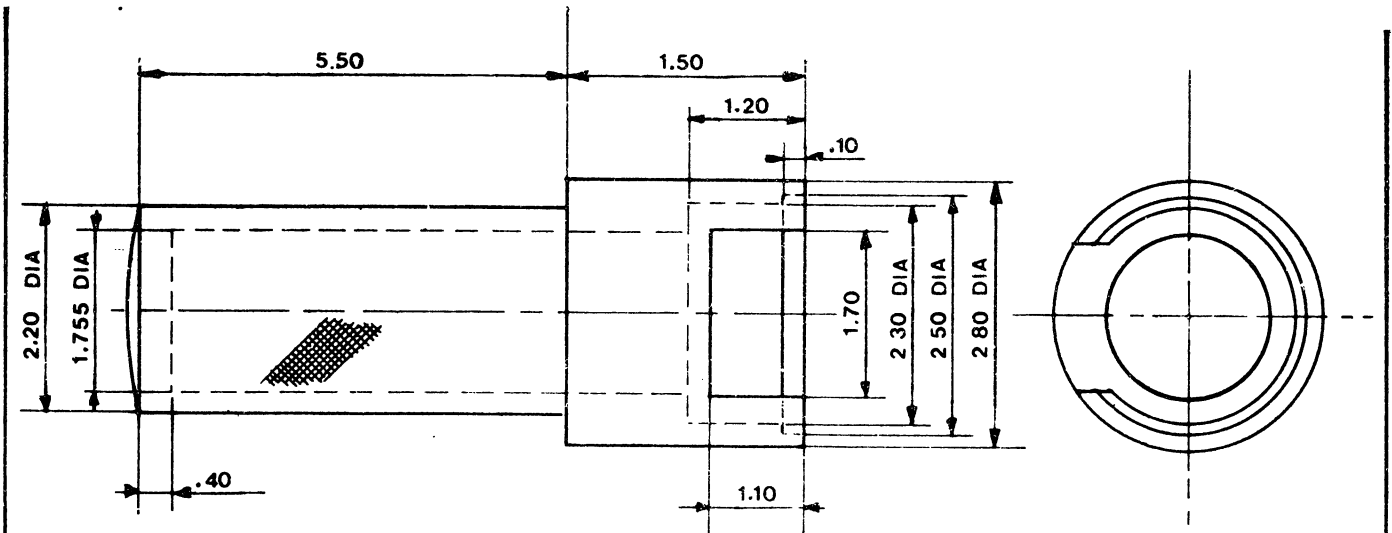
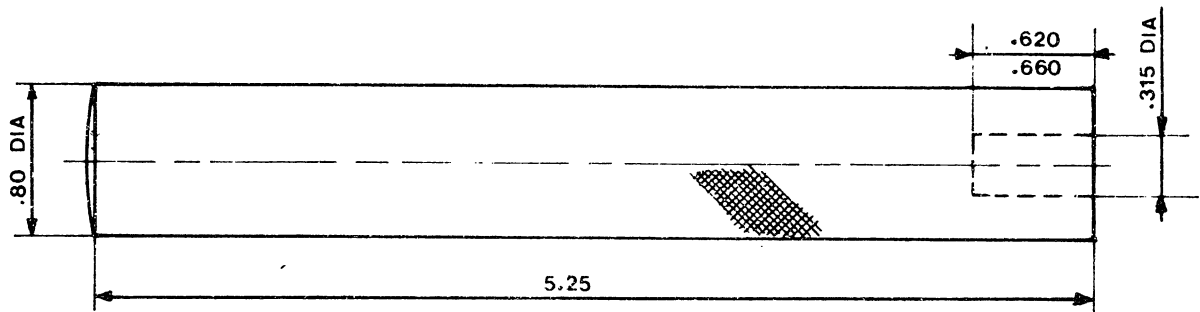

Fig.52 . SPECIAL TOOL TD 300 323



MATERIAL : STEEL SAE 4140 H.T. to HRc 42 - 46

Fig. 53 . SPECIAL TOOL TD 300 342



MATERIAL : STEEL SAE 4140

Fig. 54 . SPECIAL TOOL TD 300 344

SPECIAL HYDRAULIC TOOL TO SEPARATE TAPER ASSEMBLIES

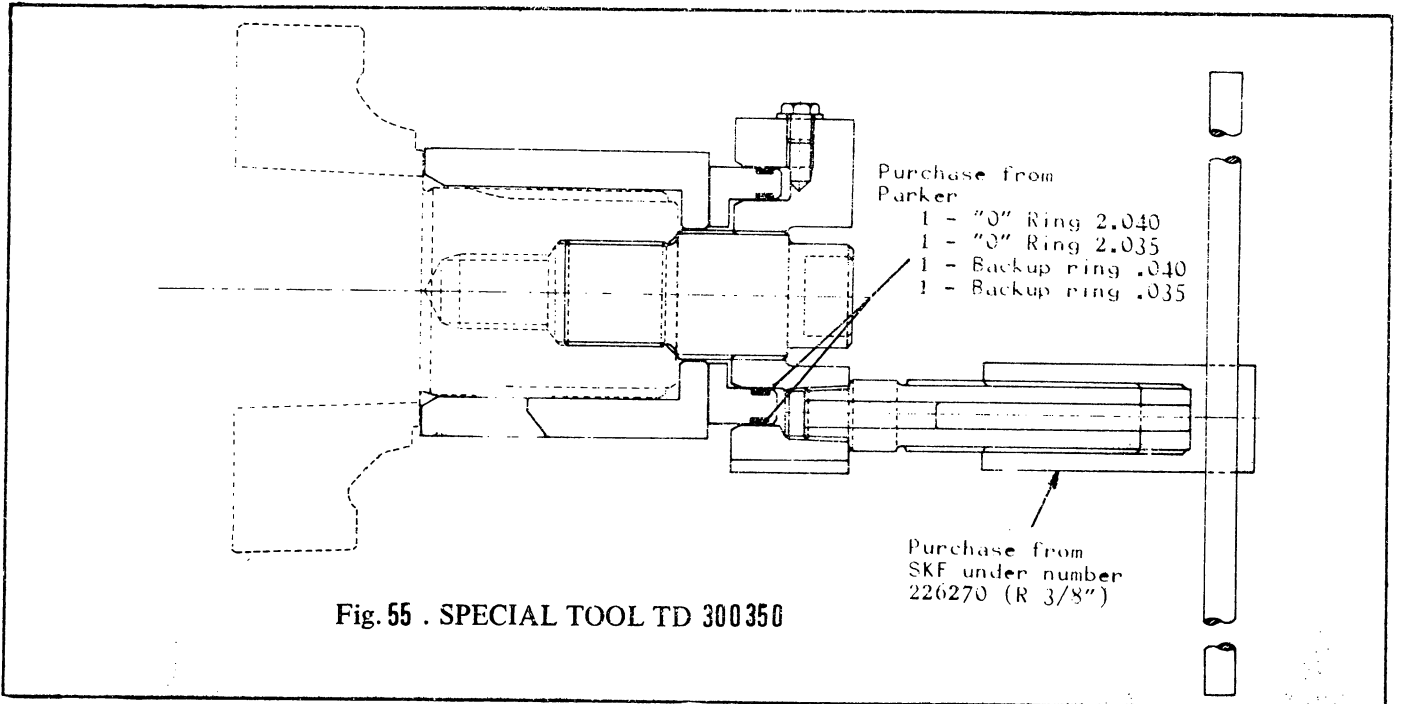
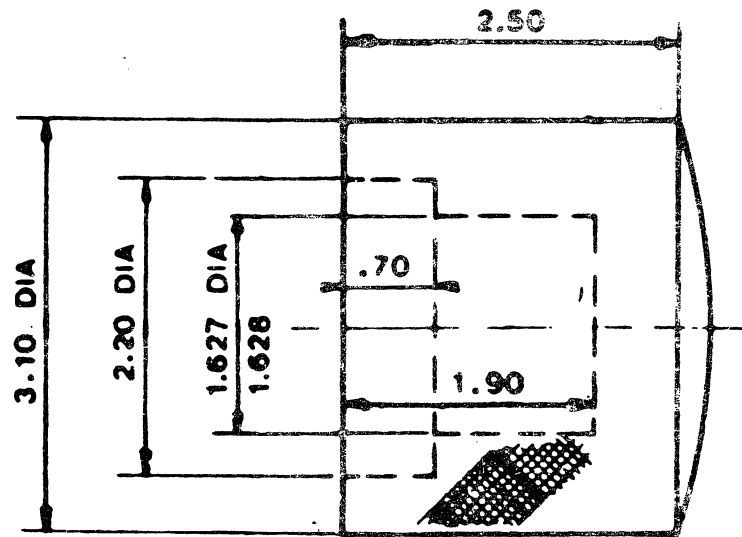

Fig. 55 . SPECIAL TOOL TD 300 350

DETAIL DRAWINGS OF TD 300350



MATERIAL : STEEL SAE 4140

FIG. 56 SPECIAL TOOL TD 300336

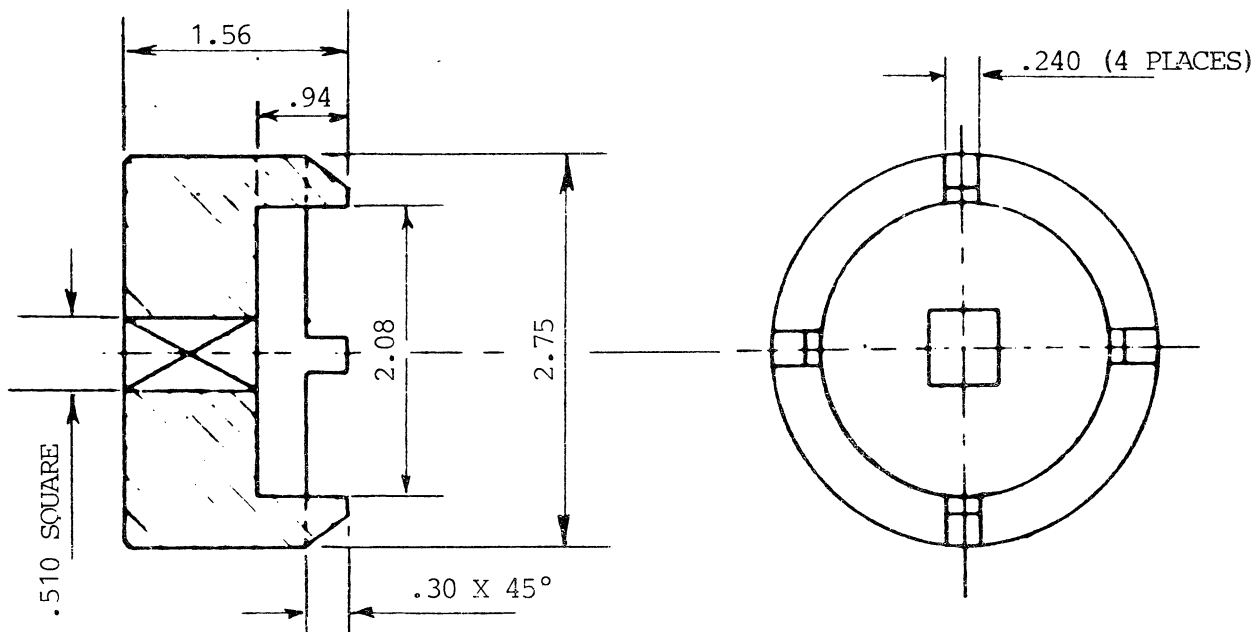

MATERIAL : STEEL SAE 4140 H.T. to HRC 42 - 46

FIG. 56 BIS SPECIAL TOOL TD 300351

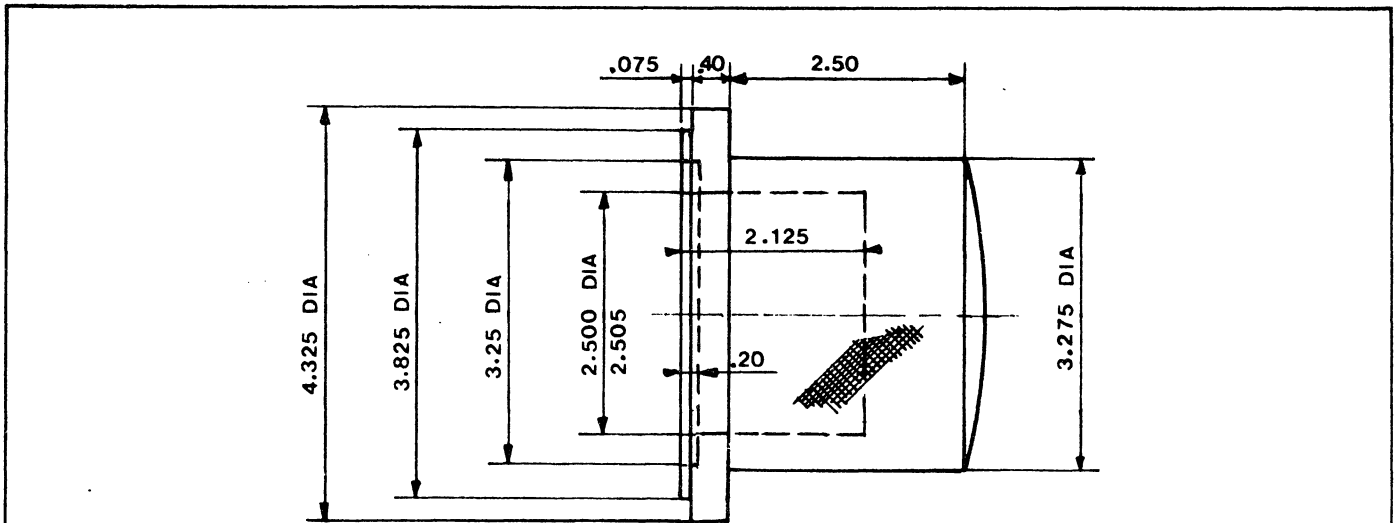

MATERIAL : STEEL SAE 4140

Fig. 57. SPECIAL TOOL TD 300 339

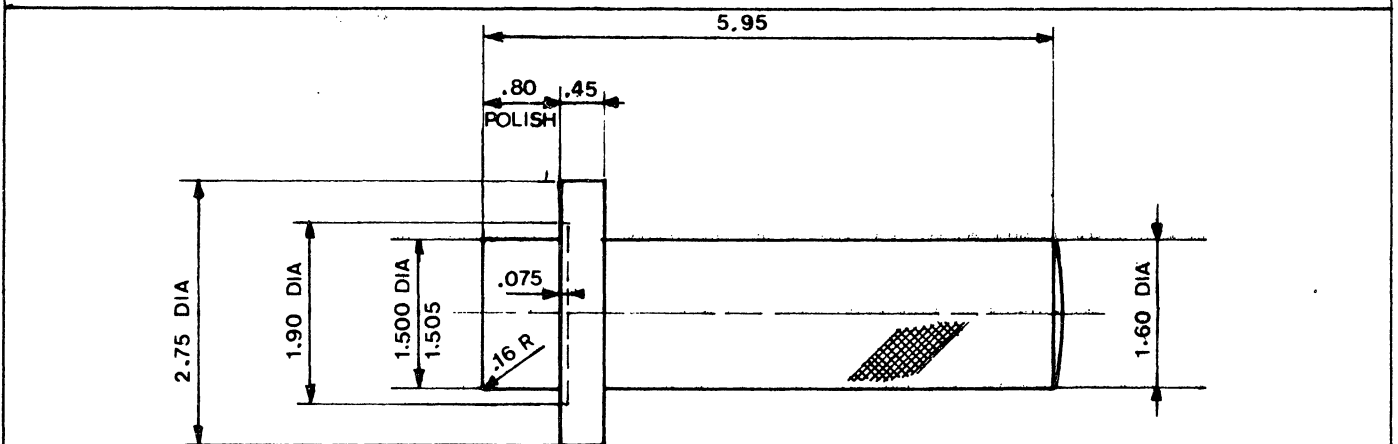

MATERIAL : STEEL SAE 4140

Fig. 58. SPECIAL TOOL TD 300 337

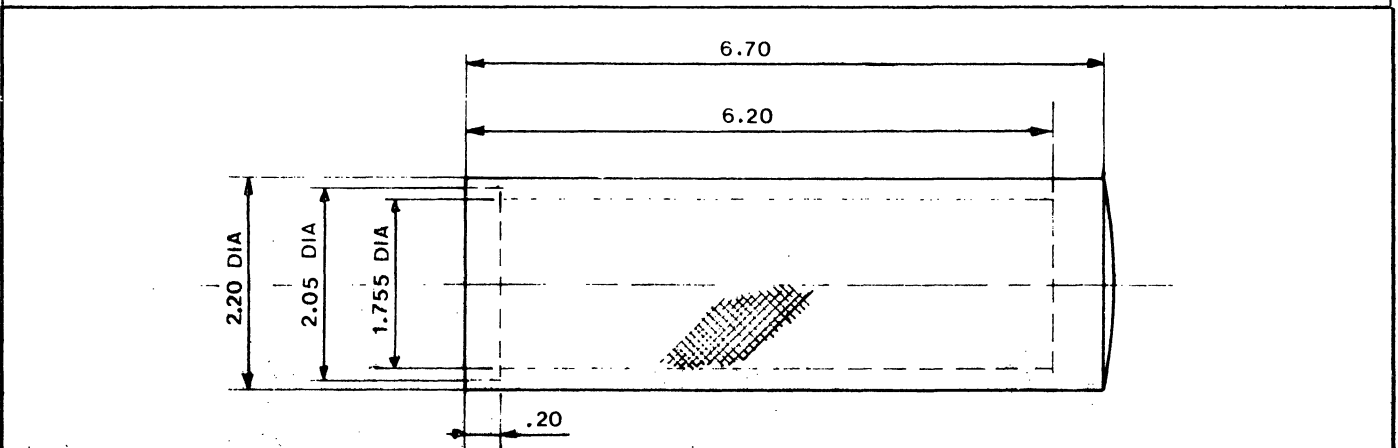

MATERIAL : STEEL SAE 4140 H.T. to HRc 42-46

Fig. 59. Special Tool TD 300 341

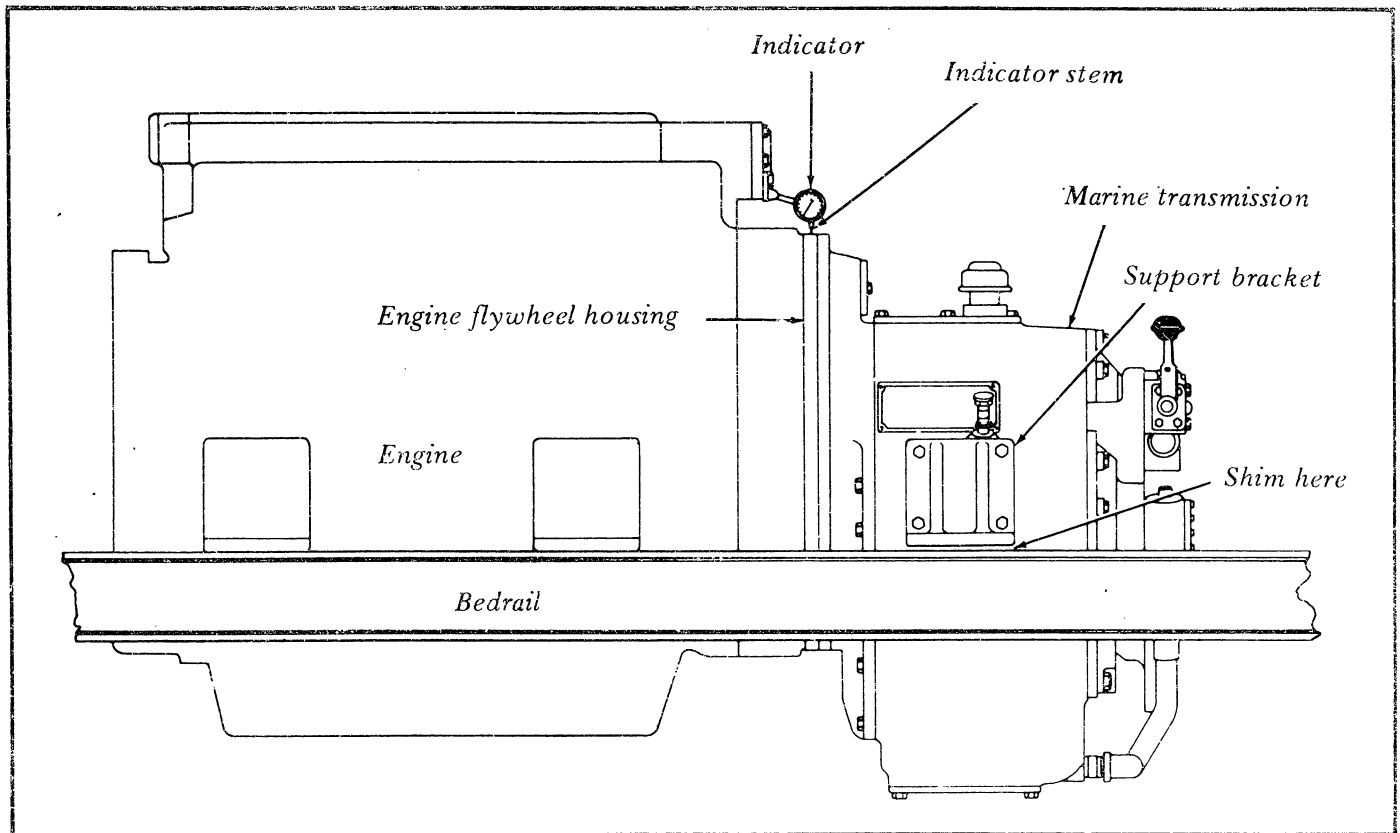

Fig. 60 . Alignment of Engine and Marine Transmission - Schematic (typical).

ALIGNMENT

Proper alignment of an engine and marine transmission is critical. . . both during the initial installation and at frequent intervals during the life of the boat. It is quite common for a boat to change its form under various loads and with age. A bend is actually formed in the keel which changes the original engine and shaft alignment. The following steps may be taken to ensure proper marine transmission alignment.

PROPELLER SHAFT INSTALLATION

(1) A wire is run through the shaft log and secured to a brace near the engine bed, giving the wire a position equivalent to the shaft centerline.

(2) The stern bearing and stuffing box are installed and bolted into position with the wire passing through each in the exact center of the bore. With the bearing and stuffing box in place, the wire is then removed.

(3) The propeller shaft is then installed in its proper position.

(4) If an intermediate shaft is used, it is blocked into position and its coupling is aligned with

the propeller shaft coupling (see the following section -- "Engine and Marine Transmission Alignment"). If there is an intermediate bearing in the line, this is installed and positioned with shims during the alignment process.

If a light shaft is used without an intermediate bearing, the shaft must be centered and supported to take out the droop while alignment of the flange couplings are being made.

ENGINE AND MARINE TRANSMISSION ALIGNMENT TO PROPELLER SHAFT

It is important to align the engine and gear only when the boat is afloat and *not* in dry-dock. During this alignment period, it is also advisable to fill the fuel tanks and add any other ballast that will be used when the boat is in service. With the engine and gear in position on the engine bed, arrangements must be made to have a controlled lifting or lowering of each of the four corners of the engine. If threaded holes are provided in each of the engine mounts, jacking screws can then be used. The engine can be raised by screwing down or lowered by backing off the desired amount on the screws. Steel plates must be inserted under the jacking screws so that the bolts will not damage the engine bed. Lifting can also be accompi-

shed by the use of chain hoists or properly placed jacks. Adjustable shims are also available and can simplify the alignment procedure particularly for future alignment.

It will also be necessary to move the engine and gear from one side or the other on the bed to secure horizontal alignment. This can be done with a jack placed horizontally between the engine and the foundation. At the same time, a straight edge is laid across the edges of the flanges at the top and sides to check the parallel alignment of the coupling edges (See Fig. 61).

As the engine and marine transmission then comes into its aligned position, it will be possible to match the male and female halves of the propeller coupling, and prepare for bolting together. Care should be taken not to burr or mar this connection because the fit is very critical. A 0.002-inch feeler gauge is inserted between the flanges of the coupling. The feeler gauge is run completely around the coupling.

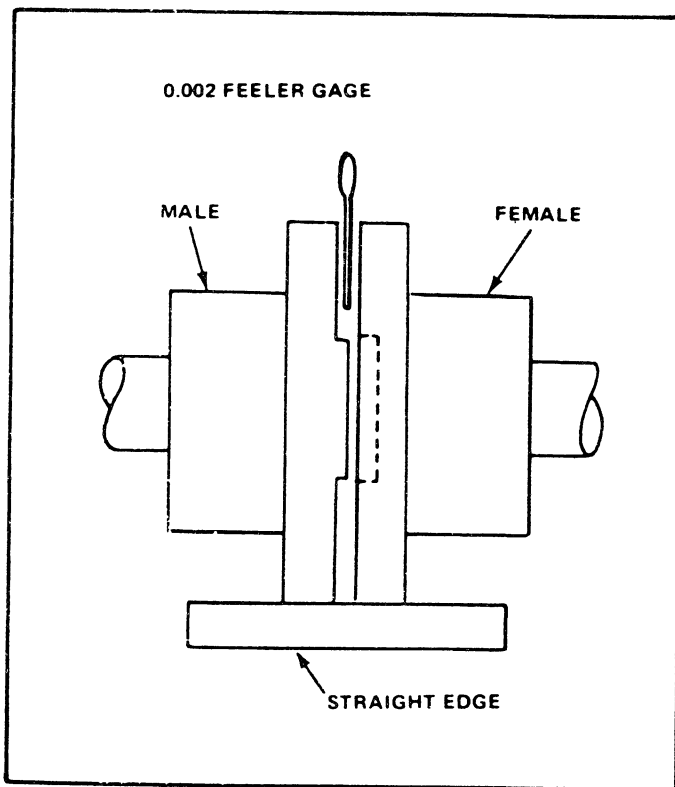

Figure 61. Checking parallel alignment of the Coupling edges.

Then the marine transmission flange coupling is rotated 90, 180 and 270 degrees with the feeler being run around the flange again in each successive position. If the alignment is correct, the feeler gauge fits snugly with the same tension all around the flange coupling.

If the alignment varies during rotation, then further alignment is necessary or the marine transmission and shaft couplings should be checked for improper face run-out. Face run-out on the marine transmission coupling can usually be corrected by repositioning the coupling on its spline. Shaft coupling run-out is usually due to inaccuracy of taper fit or key interference.

Some boats are not structurally rigid and some carry their load in such a way that they will "hog" or go out of normal shape with every loading and unloading. Where this condition exists, it may be necessary to make a compromise between the top and bottom coupling clearance by leaving a greater clearance at the bottom of the marine transmission and propeller coupling. This clearance might be 0.005 to 0.007 inch while the top would maintain the standard 0.002 inch.

During the process of securing final alignment, it may be necessary to shift the engine many times. When it becomes apparent that the alignment is reasonably close, the holes for the lag studs are marked and drilled. Then with final alignment completed, the necessary steel or hardwood shims are produced and the engine and gear is fastened in place. The alignment is then rechecked, and if satisfactory, the coupling is bolted together.

Although it is not as necessary to align a flexible coupling as accurately as a solid coupling, the closer it is in the initial alignment, the more vibration-free it will be. The most accurate method of alignment is to align the shaft to the marine transmission while the flexible coupling is not connected. This can be done with a spacer the same size as the coupling but not flexible in nature. Flexible couplings are used only for noise and vibration dampening . . . not to correct inadequate alignment.

When the heavy boat is dry-docked, it naturally undergoes some bending. Therefore, it is always good practice to unbolt the marine transmission coupling and prevent bending of the shaft.

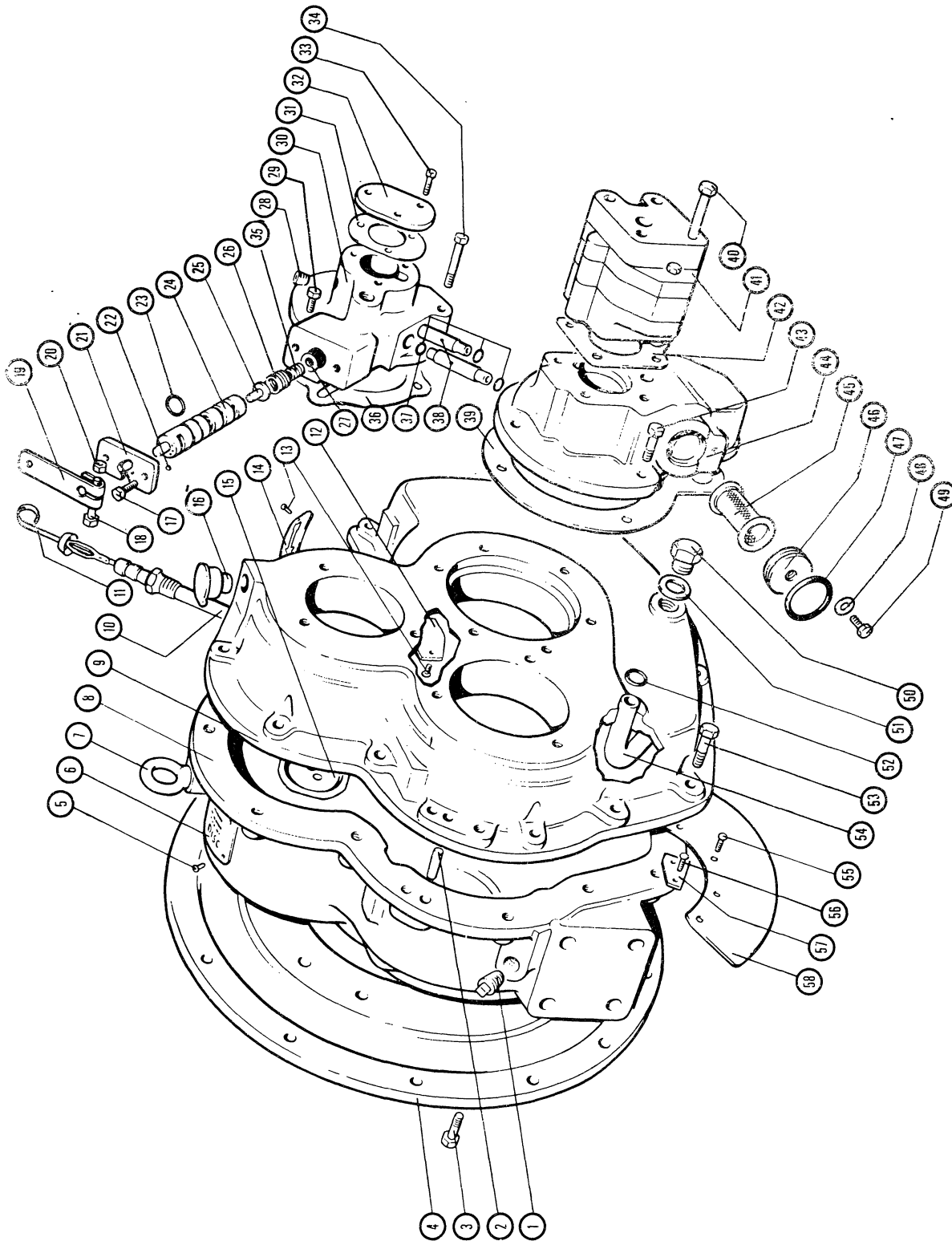

Fig. 62 . Housing, Valve and Pump group of parts -
Exploded View.

FIGURE 62. EXTERNAL PARTS GROUP.

Item	Description	Quantity
1.	PLUG, oil tube and disptick hole (alternate).	1
2.	PIN, dowel*	2
3.	CAPSCREW, hex.head (M10X1,5X25)	10
4.	ADAPTOR, plate	1
5.	SCREW, drive	4
6.	PLATE, name	1
7.	EYEBOLT	1
8.	HOUSING, front half*	1
9.	HOUSING, rear half*	1
10.	TUBE, oil level gauge	1
11.	GAUGE, oil level (dipstick)	1
12.	SHIELD, oil retainer	1
13.	SCREW, drive	4
14.	PLATE, flywheel direction of rotation	1
15.	SHIELD, oil retainer	1
16.	FILTER-BREATHER, oil cap	1
17.	CAPSCREW, hex.head (5/16-18X3/4)	2
18.	CAPSCREW, hex.head (1/4-20 X 1)	1
19.	LEVER, shift	1
20.	NUT (1/4 - 20)	1
21.	PLATE, detent*	1
22.	BALL, steel*	1
23.	"O" RING	1
24.	SPOOL, valve	1
25.	PISTON, regulator	1
26.	SPRING, compression, outer	1
27.	WASHER, steel	1

* Parts are not replaceable separately.



FIGURE 62. EXTERNAL PARTS GROUP.

Item	Description	Quantity
28.	PLUG 1/8 27 NPT	1
29.	CAPSCREW, hex.head (M10 X 1,5 X 25)	2
30.	BODY, main regulator valve*	1
31.	GASKET, valve cover	1
32.	COVER, regulator valve	1
33.	CAPSCREW, hex.head (5/16 - 18 X 3/4)	3
34.	CAPSCREW, hex.head (M10 X 1,5 X 50)	1
35.	SPRING, compression, inner	1
36.	SHIM .005	as req'd
	SHIM .007	as req'd
	SHIM .020	as req'd
37.	"O" RING	4
38.	TUBE, connector	2
39.	SHIM .005	as req'd
	SHIM .007	as req'd
	SHIM .020	as req'd
40.	PUMP, oil assembly	1
41.	CAPSCREW, hex.head (M8 X 1,25 X 110)	4
42.	GASKET, pump	1
43.	CAPSCREW, hex.head (M10 X 1,5 X 25)	3
44.	MUNT, pump	1
45.	STRAINER, pump suction	1
46.	COVER, strainer	1
47.	"O" RING	1
48.	WASHER	1

* Parts are not replaceable separately.

Item	DESCRIPTION	Quantity
51.	PLUG	1
52.	RING, internal snap	1
53.	PISTON, regulator	1
54.	SPRING, compression, inner	1
55.	SPRING, compression, outer	1
56.	PISTON, pressure rise	1
57.	PUMP, oil assembly	1
58.	CAPSCREW, hex.head (M8 x 1,25 x 110)	4
59.	GASKET, pump	1
60.	CAPSCREW, hex.head (M10 x 1,5 x 25)	3
61.	MOUNT, pump	1
62.	SHIM .005	as req'd
	SHIM .007	as req'd
	SHIM .020	as req'd
63.	STRAINER, pump suction	1
64.	COVER, strainer	1
65.	"O" RING	1
66.	WASHER	1
67.	CAPSCREW, hex.head (M8 x 1,25 x 12)	1
68.	PLUG, drain	1
69.	"O" RING	1
70.	"O" RING	1
71.	CAPSCREW, hex.head (M10 x 1,5 x 30)	17
72.*	TUBE, suction*	1
73.	SCREW, drive	5
74.	SCREW, drive	2
75.	SHIELD, oil retainer	1
76.	SHIELD, oil retainer	1

* Parts are not serviceable separately.

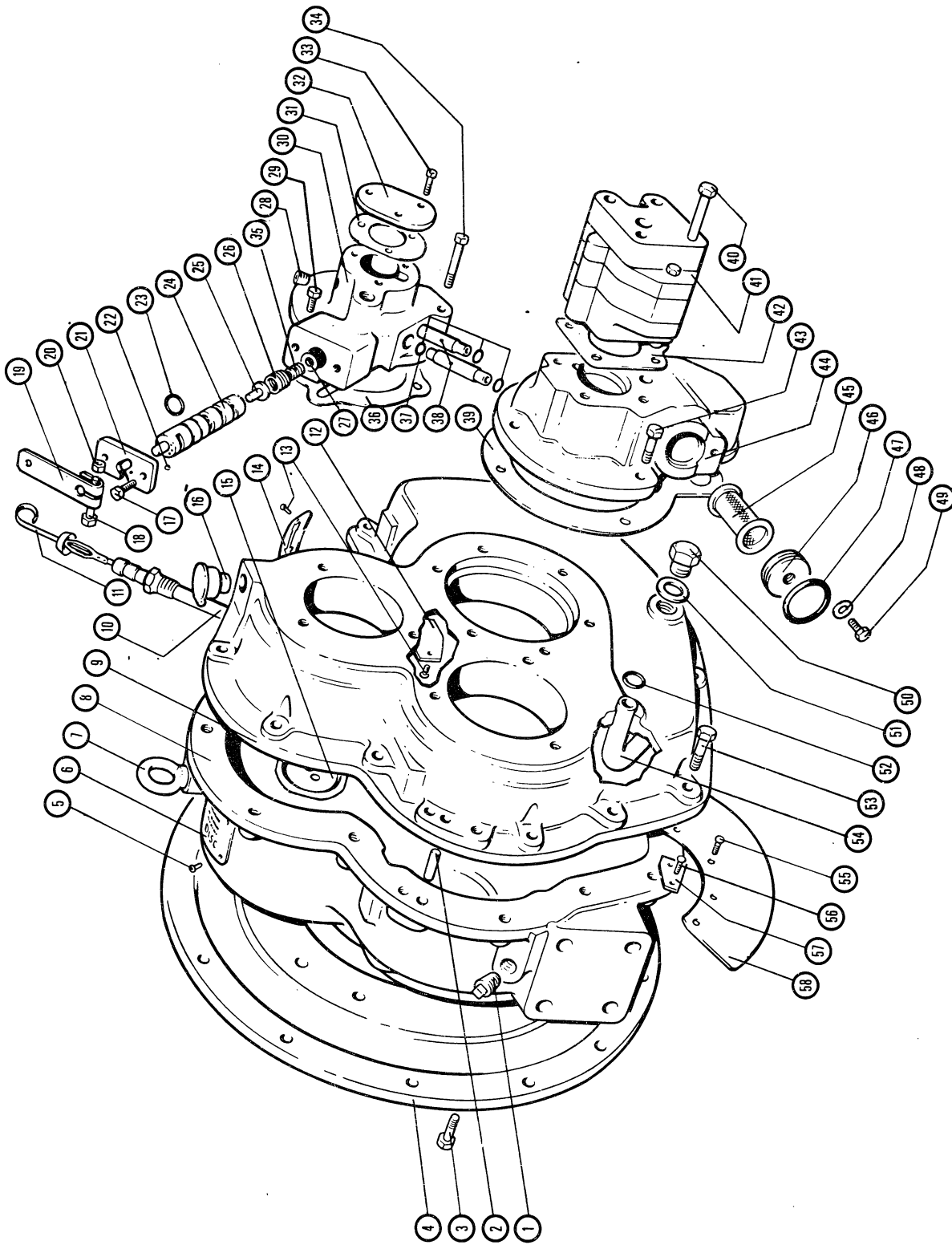

Fig. 62. a Housing, Valve with pressure rate of rise control (optional) and Pump group of parts

Exploded View.

FIGURE 62.a EXTERNAL PARTS GROUP.

Item	Description	Quantity
1.	PLUG, oil tube and disptick hole (alternate).	1
2.	PIN, dowel*	2
3.	CAPSCREW, hex.head (M10X1,5X25)	10
4.	ADAPTOR, plate	1
5.	SCREW, drive	4
6.	PLATE, name	1
7.	EYEBOLT	1
8.	HOUSING, front half*	1
9.	HOUSING, rear half*	1
10.	TUBE, oil level gauge	1
11.	GAUGE, oil level (dipstick)	1
12.	SHIELD, oil retainer	1
13.	SCREW, drive	4
14.	PLATE, flywheel direction of rotation	1
15.	SHIELD, oil retainer	1
16.	FILTER-BREATHER, oil cap	1
17.	CAPSCREW, hex.head (5/16-18X3/4)	2
18.	CAPSCREW, hex.head (1/4-20 X 1)	1
19.	LEVER, shift	1
20.	NUT (1/4 - 20)	1
21.	PLATE, detent*	1
22.	BALL, steel*	1
23.	"O" RING	1
24.	SPOOL, valve	1
25.	PISTON, regulator	1
26.	SPRING, compression, outer	1
27.	WASHER, steel	1

* Parts are not replaceable separately.

FIGURE 62.a EXTERNAL PARTS GROUP.

Item	Description	Quantity
28.	PLUG 1/8 27 NPT	1
29.	CAPSCREW, hex.head (M10 X 1,5 X 25)	2
30.	BODY, main regulator valve*	1
31.	GASKET, valve cover	1
32.	COVER, regulator valve	1
33.	CAPSCREW, hex.head (5/16 - 18 X 3/4)	3
34.	CAPSCREW, hex.head (M10 X 1,5 X 50)	1
35.	SPRING, compression, inner	1
36.	SHIM .005	as req'd
	SHIM .007	as req'd
	SHIM .020	as req'd
37.	"O" RING	4
38.	TUBE, connector	2
39.	SHIM .005	as req'd
	SHIM .007	as req'd
	SHIM .020	as req'd
40.	PUMP, oil assembly	1
41.	CAPSCREW, hex.head (M8 X 1,25 X 110)	4
42.	GASKET, pump	1
43.	CAPSCREW, hex.head (M10 X 1,5 X 25)	3
44.	MUNT, pump	1
45.	STRAINER, pump suction	1
46.	COVER, strainer	1
47.	"O" RING	1
48.	WASHER	1

* Parts are not replaceable separately.

FIGURE 62. EXTERNAL PARTS GROUP.

Item	Description	Quantity
49.	CAPSCREW, hex.head (M8 X 1,25 X 12)	1
50.	PLUG, drain	1
51.	"O" RING	1
52.	"O"RRING	1
53.	CAPSCREW, hex.head (M10 X 1,5 X.30)	17
54.	TUBE, suction *	1
55.	SCREW, drive	5
56.	SCREW, drive	2
57.	SHIELD, oil retainer	1
58.	SHIELD, oil retainer	1

* Parts are not replaceable separately.

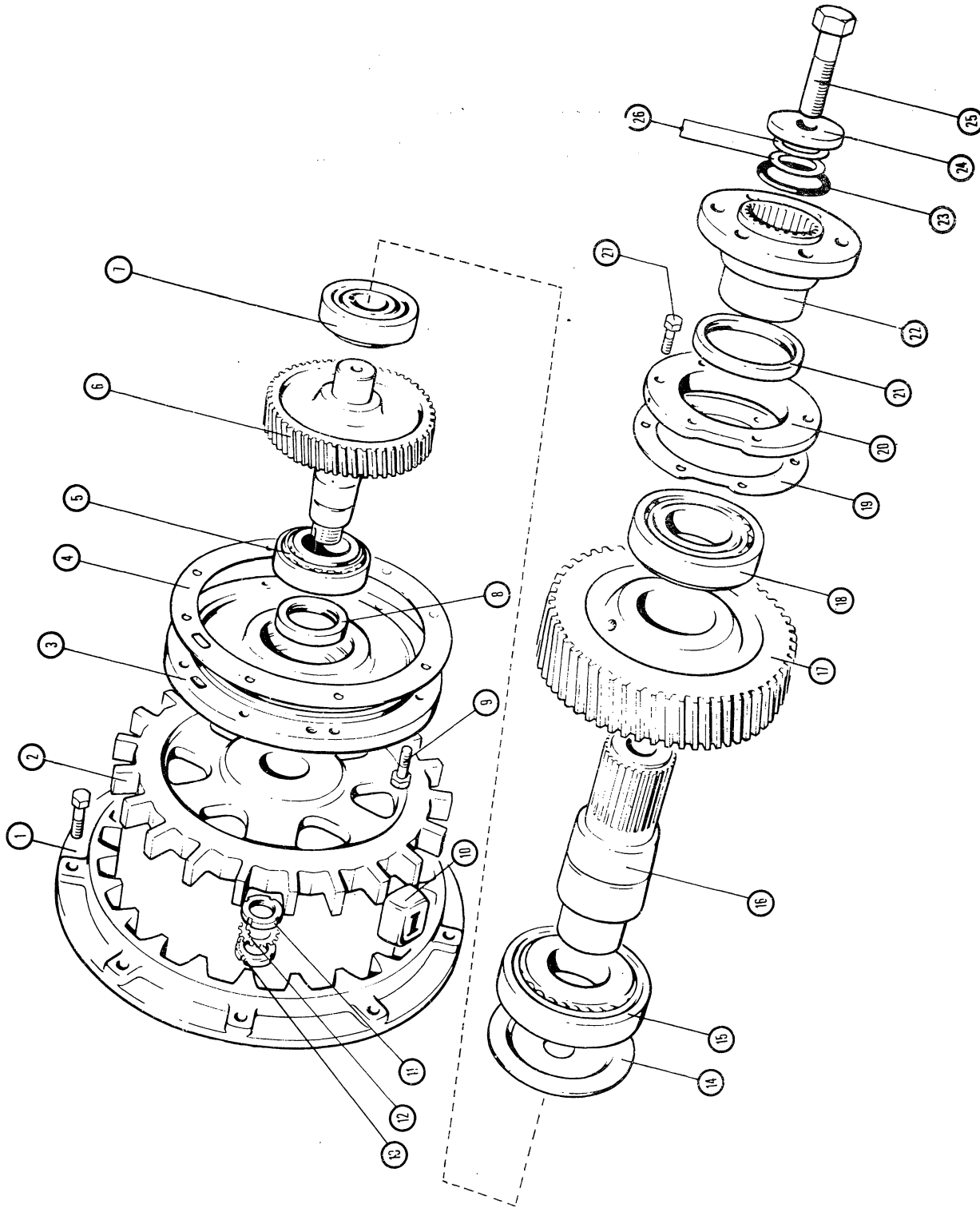

Fig. 63 . Input and output group of parts -
Exploded View.

FIGURE 63. INPUT AND OUTPUT GROUP OF PARTS.

Item	Description	Quantity
1.	RING, drive	1
2.	SPIDER, drive	1
3.	SUPPORT, bearing	1
4.	SHIM .005	as req'd
	SHIM .007	as req'd
	SHIM .020	as req'd
5.	BEARING, tapered roller	1
6.	SHAFT, input	1
7.	BEARING, tapered roller	1
8.	SEAL, oil lip (input shaft)	1
9.	CAPSCREW, hex.head (M10X1,5X25)	6
10.	BLOCK, rubber	20
11.	LOCK NUT	1
12.	WASHER LOCK	1
13.	LOCK NUT	1
14.	SHIELD, oil retainer	1
15.	BEARING, tapered roller	1
16.	SHAFT, output	1
17.	GEAR, output	1
18.	BEARING, tapered roller	1
19.	SHIM .005	as req'd
	SHIM .007	as req'd
	SHIM .020	as req'd
20.	RETAINER, bearing	1
21.	SEAL, oil lip (output flange)	1
22.	FLANGE, ouptut	1
23.	RING, lathe cut seal	1
24.	WASHER, retainer (output flange)	1
25.	CAPSCREW, hex.head (7/8-9X3)	1
26.	SHIM	as req'd
27.	CAPSCREW, hex.head (M10X1,5X25)	6

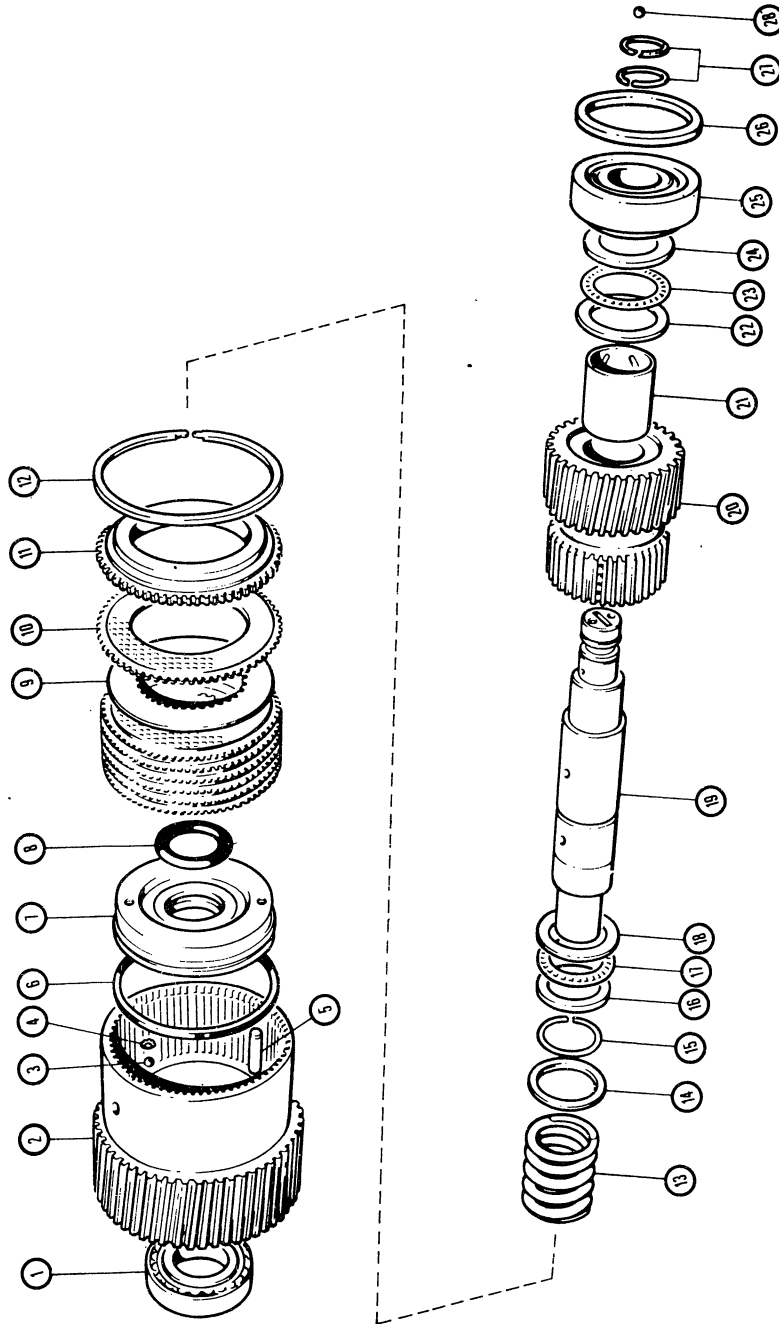

Fig. 64 . Forward clutch group of parts -
Exploded View.

FIGURE 64. FORWARD CLUTCH GROUP OF PARTS.

Item	DESCRIPTION	Quantity
1.	BEARING, tapered roller	1
2.*	GEAR, clutch housing forward*	1
3.	BALL, steel	1
4.	RING, retaining, self locking	1
5.	PIN, dowel, antirotation	1
6.	RING, lathe cut seal	1
7.	PISTON, clutch	1
8.	"O" RING, seal	1
9.	PLATE, clutch, steel	6
10.	PLATE, clutch, faced	7
11.	PLATE, back	1
12.	RING, internal snap	1
13.	SPRING, compression, return piston	1
14.	WASHER, spring retainer, steel	1
15.	RING, external snap, round section	1
16.	WASHER, race thrust, steel	1
17.	BEARING, needle thrust	1
18.	WASHER, race thrust, steel	1
19.*	SHAFT, clutch assembly*	1
20.*	HUB, clutch pinion, assembly*	
21.*	BUSHING, pinion*	1
22.	WASHER, race thrust, steel	1
23.	BEARING, needle thrust	1
24.	WASHER, race thrust, steel	1
25.	BEARING, tapered roller	1
26.	SPACER	1
27.	RING, seal, piston type	2
28.*	BALL, steel*	1

* Parts are not replaceable separately.

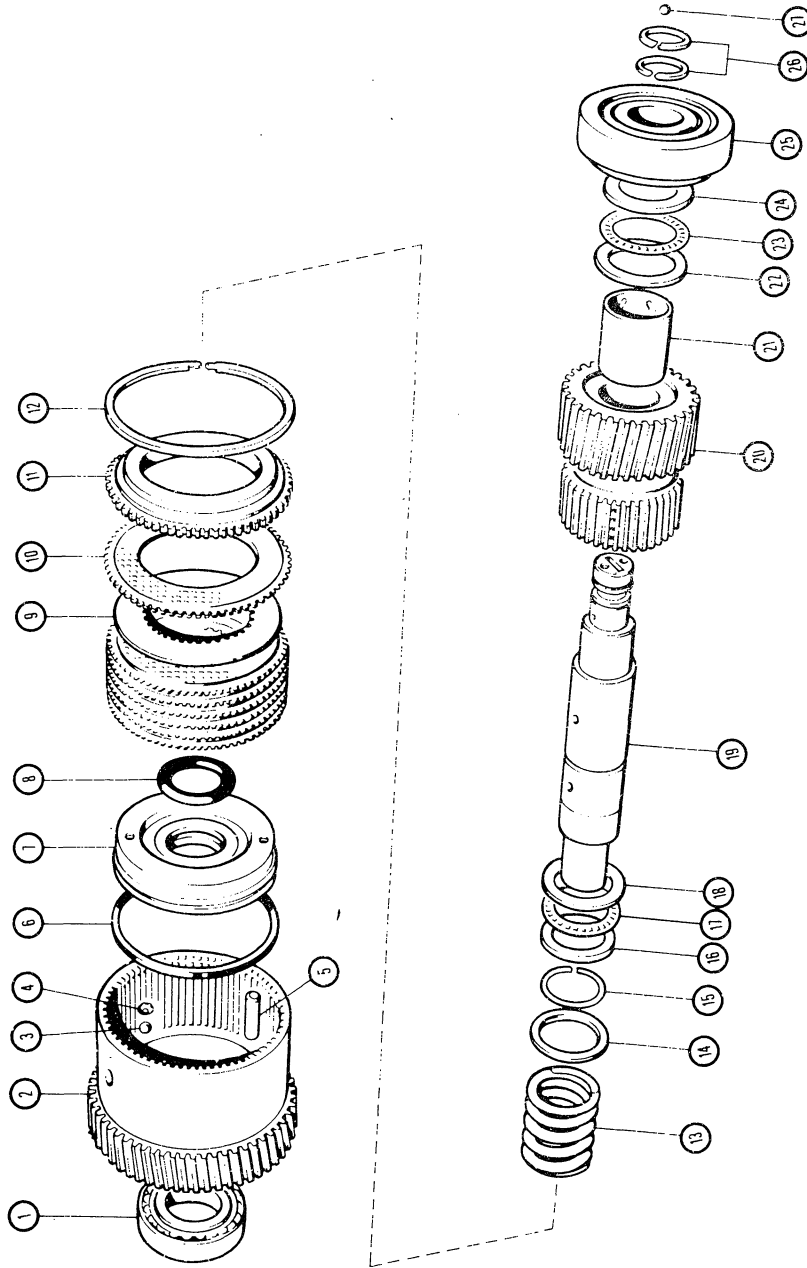

Fig. 65 . Reverse clutch group of parts -
Exploded View.

FIGURE 65. REVERSE CLUTCH GROUP OF PARTS



Item	DESCRIPTION	Quantity
1.	BEARING, tapered roller	1
2.*	GEAR, clutch housing, reverse*	1
3.	BALL, steel	1
4.	RING, retaining, self locking	1
5.	PIN, dowel, antirotation	1
6.	RING, lathe cut seal	1
7.	PISTON, clutch	1
8.	"O" RING, seal	1
9.	PLATE, clutch, steel	6
10.	PLATE, clutch, faced	7
11.	PLATE, back	1
12.	RING, internal snap	1
13.	SPRING, compression, return piston	1
14.	WASHER, spring retainer, steel	1
15.	RING, external snap, round section	1
16.	WASHER, race thrust, steel	1
17.	BEARING, needle thrust	1
18.	WASHER, race thrust, steel	1
19.*	SHAFT, clutch assembly*	1
20.*	HUB, clutch pinion, assembly*	1
21.*	BUSHING, pinion*	1
22.	WASHER, race thrust, steel	1
23.	BEARING, needle thrust	1
24.	WASHER, race thrust, steel	1
25.	BEARING, tapered roller	1
26.	RING, seal, piston type	2
27.*	BALL, steel*	1

* Parts are not replaceable separately.

TORQUE VALUES : FOR TIGHTENING BOLTS & NUTS					LIMITING CONDITIONS				
DIN GRADE	6.9	8.8	10.9	12.9	DIN GRADE	6.9	8.8	10.9	12.9
METRIC THREAD FINE THREADS	TORQUE VALUES				METRIC THREAD NORMAL THREADS	TORQUE VALUES			
	Ft.Lb Kgm	Ft.Lb Kgm	Ft.Lb Kgm	Ft.Lb Kgm		Ft.Lb Kgm	Ft.Lb Kgm	Ft.Lb Kgm	Ft.Lb Kgm
M 5 x 0,5	4,5	5	7,3	8,7	M 5 x 0,8	3,6	4,5	6,5	8
	0,6	0,7	1,0	1,2		0,5	0,6	0,9	1,1
M 6 x 0,5	7,2	9,5	12,3	15,2	M 6 x 1	6,5	8,0	10,8	14
	1,0	1,3	1,7	2,1		0,9	1,1	1,5	1,8
M 8 x 1	19,5	22	30	36	M 8 x 1,25	16	18	25	31
	1,7	3,0	4,1	5,0		2,2	2,5	3,4	4,3
M 10 x 1	36	41	57	69	M 10 x 1,5	31	34	47	60
	5,0	5,5	7,8	9,5		4,3	4,7	6,5	8,3
M 12 x 1,5	60	69	98	118	M 12 x 1,75	53	56	82	100
	8,3	9,5	13,5	16		7,3	7,8	11,3	14,0
M 14 x 1,5	92	104	146	176	M 14 x 2	80	86	126	155
	12,8	14	20	24		11	12	17,5	21,5
M 16 x 1,5	130	148	210	253	M 16 x 2	123	130	188	224
	18	20	29	35		17	18	26	31
M 18 x 1,5	180	195	282	340	M 18 x 2,5	166	181	260	310
	25	27	39	47		23	25	36	43
M 20 x 1,5	246	256	362	435	M 20 x 2,5	228	242	340	405
	34	35	50	60		31,5	33,5	47	56
M 22 x 1,5	311	326	450	535	M 22 x 2,5	304	311	434	505
	43	45	63	74		42	43	60	70
M 24 x 1,5	412	425	598	720	M 24 x 3	390	405	572	690
	57	59	83	100		54	56	79	95



**TORQUE VALUES - FOR TIGHTENING CAPSCREWS,
BOLTS & PIPE PLUGS.**

CAPSCREWS, BOLTS & NUTS (1)					
TORQUE (LB. FT.) FOR COARSE AND FINE THREADS					
NOMINAL THREAD DIAMETER (INCHES)	SAE GRADE 5		SAE GRADE 8 (4)		Screws for Univ. Joint Bearing Caps
	DRY (2)	OILED (3)	DRY (2)	OILED (3)	OILED (3)
1/4	11-10	9-8	16-14	13-11	
5/16	21-19	17-15	30-27	24-21	
3/8	38-34	30-27	53-48	42-38	
7/16	55-50	44-40	78-70	62-56	67-60
1/2	85-77	68-61	118-108	95-86	105-95
9/16	125-115	100-90	177-162	140-127	
5/8	175-160	140-125	245-225	195-177	200-180
3/4	300-270	240-215	420-380	335-305	345-315
7/8	450-405	360-325	630-570	505-460	535-485
1	680-610	545-490	1100-1000	880-792	
1-1/8	860-770	690-620	1390-1250	1110-1010	
1-1/4	1150-1030	920-830	1860-1670	1490-1350	
	3 DASHES 120° APART 		6 DASHES 60° APART 		
	SAE STANDARD HEX BOLT HEAD MARKINGS				12 Pt. Head Undercut Body

PIPE PLUGS		
RECOMMENDED TORQUE (LB. FT.) *		
NPT DIAMETER (INCHES)	IRON, STEEL & BRASS PLUG OR FITTINGS	
	IN CAST IRON OR STEEL	IN ALUMINUM
1/16	6.2-4.5	
1/8	10-7.5	
1/4	20-15	
3/8	25-19	
1/2	47-35	
3/4	59-44	
1	100-80	
1-1/4	130-105	
1-1/2	150-120	

* MUST BE USED WITH COMPOUND, JOHN CRANE INSOLUBLE PLASTIC LEAD SEAL NO. 2 OR EQUIVALENT.

THIS TABLE COVERS TIGHTENING TORQUES FOR LEAK PROOF JOINTS SEALING OIL UP TO 500 PSI AND AIR UP TO 100 PSI AND VACUUM LINES. CAN USE 2/3 OF ABOVE VALUES IF NOT OVER 5 PSI OIL OR 3 PSI AIR IS BEING SEALED. TORQUEING HOT UNITS TENDS TO CAUSE MORE DIFFICULT PLUG REMOVAL.

(1) TORQUE VALUES FOR CAPSCREWS AND BOLTS ALSO APPLY TO USE IN ALUMINUM PROVIDED THE THREAD ENGAGEMENT IS TWICE THE NOMINAL THREAD DIAMETER AND A HARDENED FLAT STEEL WASHER IS USED UNDER THE HEAD. THIS TABLE COVERS TIGHTENING TORQUES FOR THE MAJORITY OF TWIN DISC'S USE OF CAPSCREWS AND BOLTS IN THREADED STEEL, CAST IRON, ALUMINUM AND BRASS PARTS. INDIVIDUAL ASSEMBLY DRAWINGS WILL SHOW SPECIAL REQUIREMENTS.

(2) USE FOR ALL CAPSCREWS, BOLTS AND NUTS WHEN DRY OR COATED ONLY WITH A RUST PREVENTATIVE WHICH IS DRY TO THE TOUCH.

(3) USE FOR ALL FASTENERS LUBRICATED WITH MOLY-DISULFIDE, WHEN PLATED WITH ZINC OR CADMIUM, OR WHEN DIPPED IN LUBRICATING OIL.

(4) SOCKET HEAD SCREWS AND 12 POINT HEAD SCREWS WITH FULL BODY ARE ALSO GRADE 8.

SECTION 15 - ACCESSORIES AND OPTIONAL EQUIPMENT.

CONTROL VALVE GROUP WITH PRESSURE RATE-OF-RISE AND TROLLING SPEED CONTROL.

GENERAL.

This control valve is offered as optional equipment. Also, an after sale and installation control valve kit is available for field installation. An oil filter (less hoses) is supplied with the control valve for field installation. The control valve groups are available for units with 300-320 psi or 350-370 psi application. See planograph PX-7205-C.

A correct sized transmission lube oil heat exchanger is required to ensure adequate cooling of the transmission oil.

Under certain conditions a heat exchanger that is suitable for transmission operation at the maximum governed engine speed with the propelling clutch fully engaged (locked-up), may be too large for the trolling mode transmission oil steady state operating temperatures may be below 150° F (66° C.). Under these conditions, the output shaft speed range may be reduced. This effect can be minimized by the installation of an appropriate thermostatic oil by-pass valve to the transmission oil side circuit.

The thermostatic by-pass valve reference available as optional equipment is B 3488 (see planograph).

HYDRAULIC SYSTEM.

The control valve functions are divided in two groups operating separately or together.

1. The control valve assembly containing passages and ports for the transmission and direction of

pressurized oil within the hydraulic system. The rate-of-rise piston within the control valve assembly providing a rapid, yet smooth pressure rise for the hydraulic system during clutch engagement. Added to this function a lube main flow priority on the clutch engaged is provided through a shuttle valve device.

2. The trolling valve providing trolling speeds by varying the propeller speed with fixed engine speed. The valve accomplishes this by mechanically changing the clutch apply pressure valve spring tensions through a cam movement. This will cause the applied clutch to slip a percentage selected to hold desired trolling speed.

Control and linkage to the trolling valve operating lever are to be furnished by the customer. See planograph of trolling valve, to determine distance travel of linkage. The trolling valve lever must be moved through a 79 degrees arc from detent to plate stop to control trolling operation.

NOTE

The operator must select the trolling mode with the control valve lever in neutral and set the engine speed at or below the recommended maximum trolling speed of 1100 rpm or 40 % of match point engine speed, whichever is smallest. Install the pilot house instruction plate B-2384 in an area near the trolling valve control head in pilot house where it may be easily read.

CAUTION

Do not operate marine transmission in the trolling mode at engine speeds above the maximum trolling rpm. Failure to obey this operating transmission components, which can cause an unsafe operation condition to occur. Unsafe operating condition could result in loss

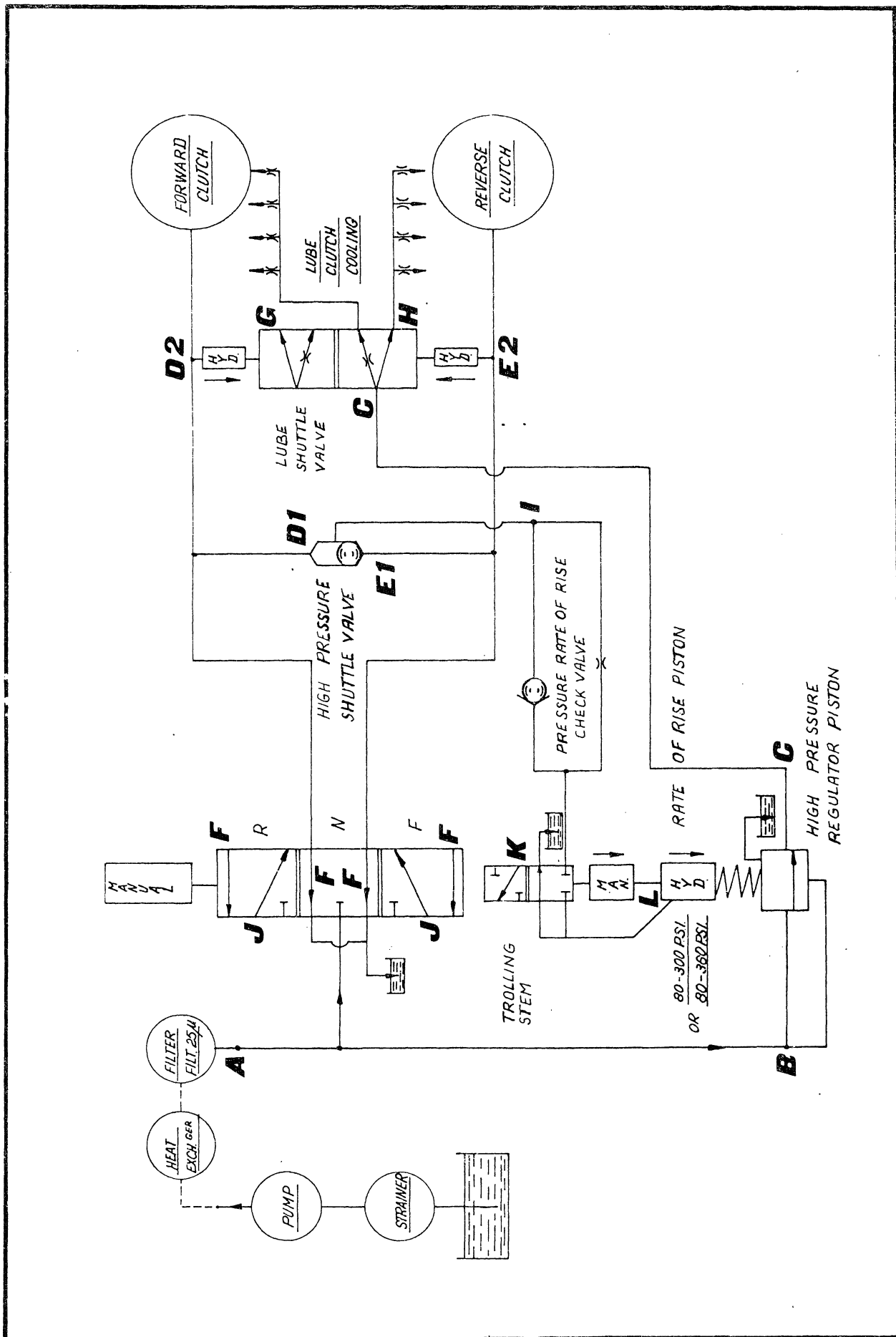

Figure 15-1 - Hydraulic Circuit Diagram.

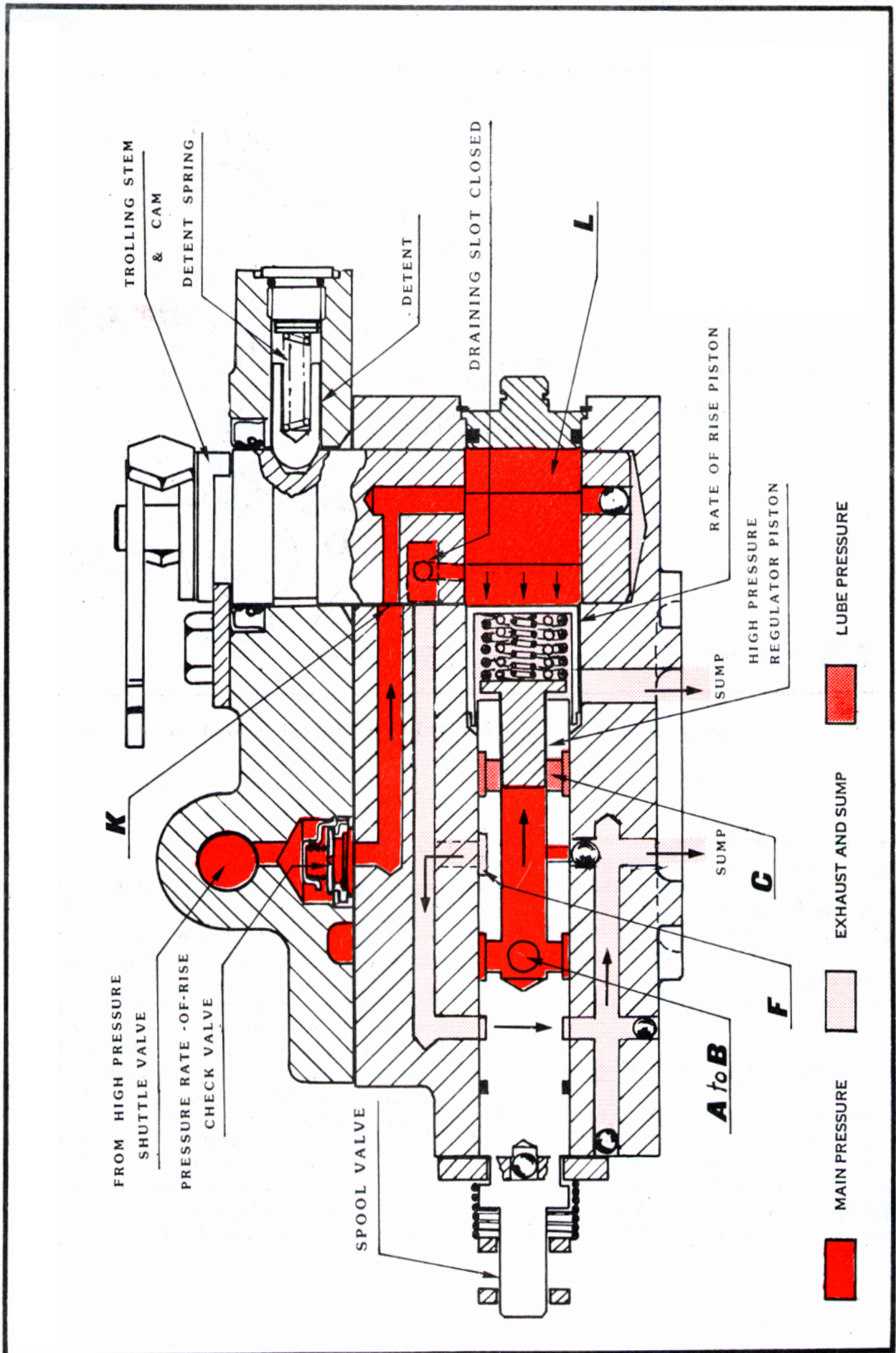

Figure 15-2 - Control Valve and Trolling Valve - Cut-away View - Non Trolling.

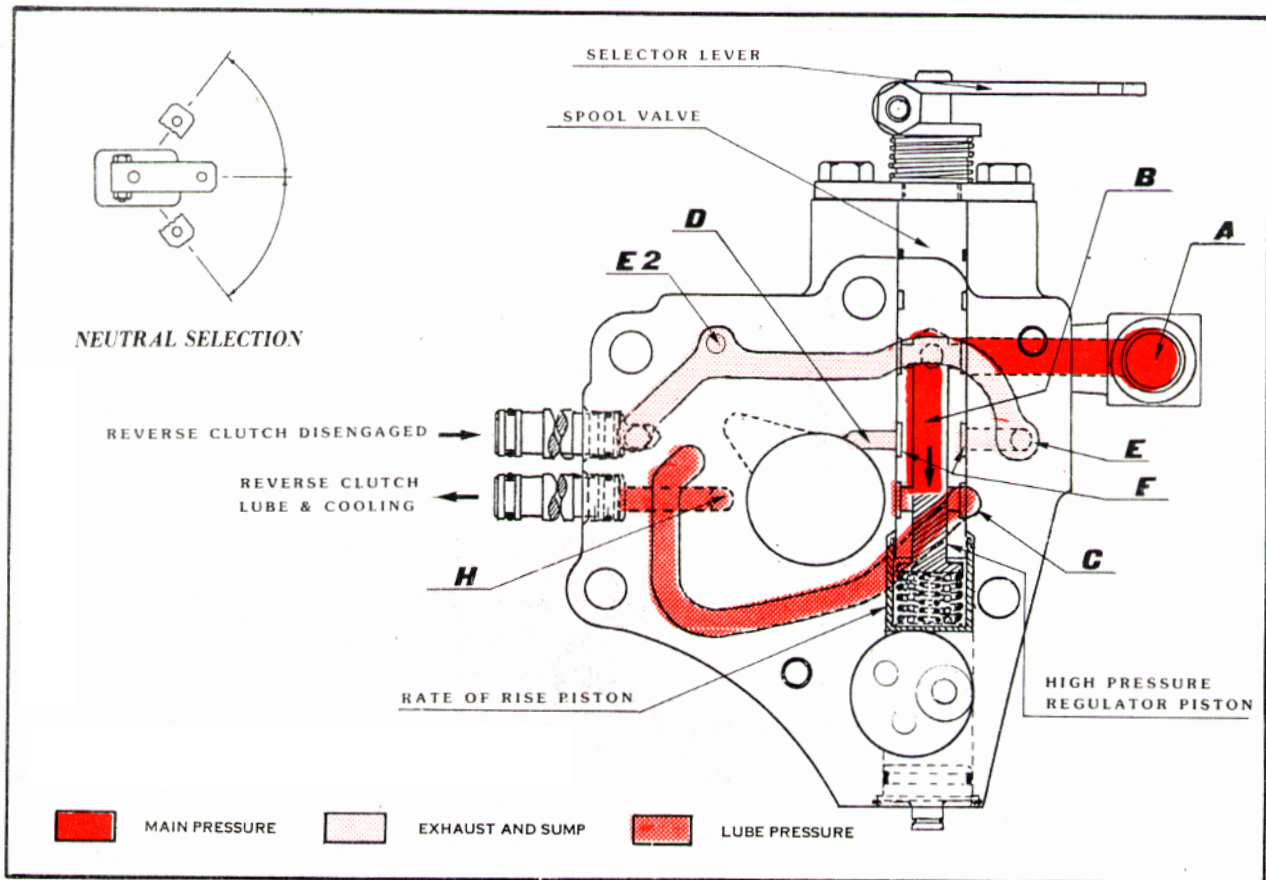

Figure 15-3 - Control Valve - Neutral - Sectional View.

of vessel manoeuvring, control vessel damage, and/or loss of property and/or life. It should be noted that when the trolling mode is used when docking, the vessel may not develop sufficient stern trust. Therefore, it is recommended that docking only be attempted in the detended or no troll position.

Control Valve - NON - Trolling Mode.

The control valve is non-trolling, when the cam trolling lever is in the detent position. See Figure 15-2. The control valve with the cam/trolling lever in the non-trolling position allows the valve to operate as a standard control valve.

Control Valve - Neutral.

See Figures 15-2, 15-3, 15-4.

Oil is drawn from the sump through the filter screen and suction tube to the oil pump assembly.

From the oil pump assembly the oil is conveyed by suitable flexible hose to the heat exchanger, the cooled oil returns from heat exchanger through a 25 μ filter assembly and suitable flexible hose to the oil inlet port A of control valve assembly and fills chamber B. The oil causes the high pressure regulator piston to partially compress the piston springs and the rate-of-rise piston. This pressurizes the oil in

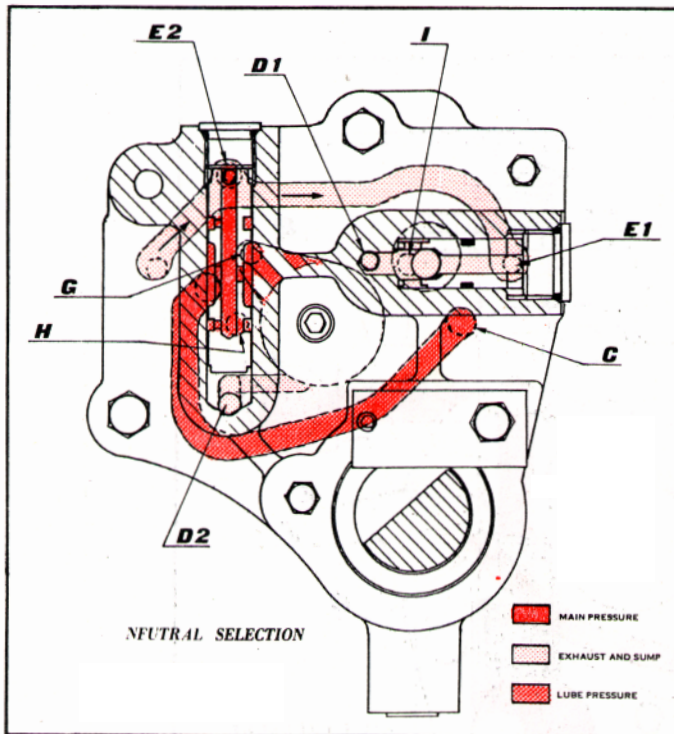

Figure 15-4 - Control Valve - Neutral - Sectional View.

chamber B. This pressure varies with engine speed (see chart for pressure limits).

The movement of the high pressure regulator piston against the springs exposes port C in the valve body. Port C directs overage oil to lubrication and clutch cooling system through a flow divider called shuttle valve. This shuttle valve conveys to the clutch selected the main flow of lube for maximum cooling and lubrication. Passage D (which is the engaging pressure outlet to the forward clutch) and passage E (which is the engaging pressure outlet to the reverse clutch) are interconnected by slot F in the control valve stem when in neutral position. The slot is aligned with drilled holes on the front face of the valve body. These drilled holes are aligned with drilled holes to pass through the main housing to sump. Therefore, passages D and E are at atmospheric pressure at this time. Also passage F is at atmospheric pressure since ports E and D are interconnected with slot F. This area

between the pistons and around the springs is vented to the sump and main housing. This area is at atmospheric pressure at all times permitting the return to sump of any leakage past the piston.

Control Valve - Forward.

See Figures 15-2, 15-5, 15-6.

When a shift to the forward position is desired the control valve lever is moved toward the engine. The shift causes the control valve stem to rotate and assume the position indicated in figure 15-5. The pressurized oil in chamber B is directed through port J to port D, which is interconnected with port D1 at high pressure shuttle valve, pushing the ball to the opposite seat provided in the shuttle valve closing the passage through port E. The pressurized oil travelling through port I reaches the rate-of-rise check valve; the rate-of-rise check valve meters the oil for a steady smooth pressure rise in chamber L through port K. As chamber L fills with oil, the rate-of-rise piston moves against the piston springs until the piston is stopped by a shoulder in the valve body. This causes the pressure in chamber B to rise to clutch engaging pressure while forward passage E remains at atmospheric pressure since slot F remains open to sump. The pressurized oil from port D travels also through port D2 causing shift of lube shuttle valve; this position of the lube shuttle valve allows main flow of lube oil to

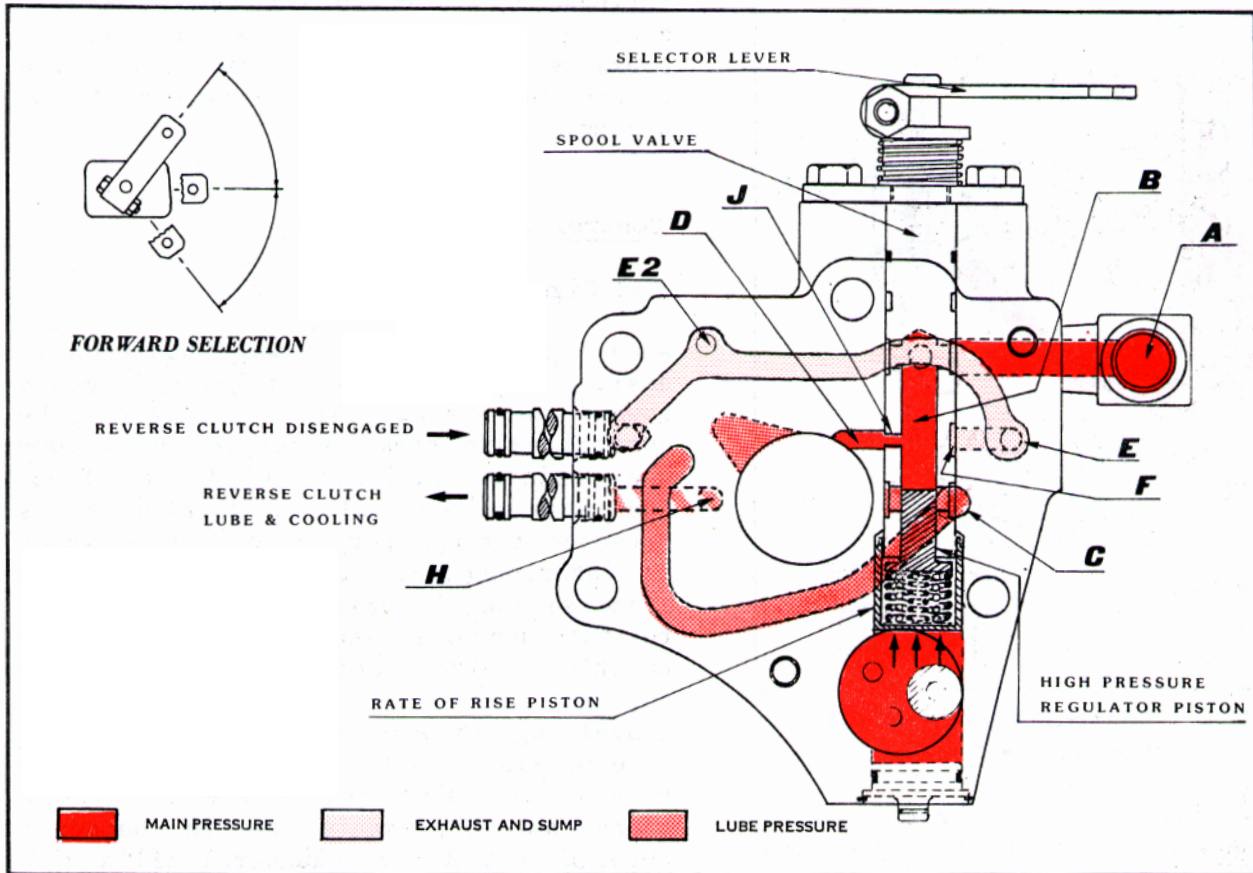

Figure 10-5. Control Valve - Forward - Sectional View.

travel through port G and partially through lube shuttle valve calibrated orifice to port H. When a shift is made from forward to neutral the valve stem is rotated to the position illustrated by Figure 15-3. Under these conditions, passage D being connected to sump by slot F, oil drains rapidly from the forward clutch to sump. Since passage I is now at atmospheric pressure the oil

pressure in chamber L unseats the plate orifice of rate-of-rise check valve against the compression spring permitting a rapid oil drain from chamber L to sump and allowing the pressure rate control piston to move back against the cam device from trolling stem. The forward clutch is now disengaged and main system pressure reduced to neutral pressure.

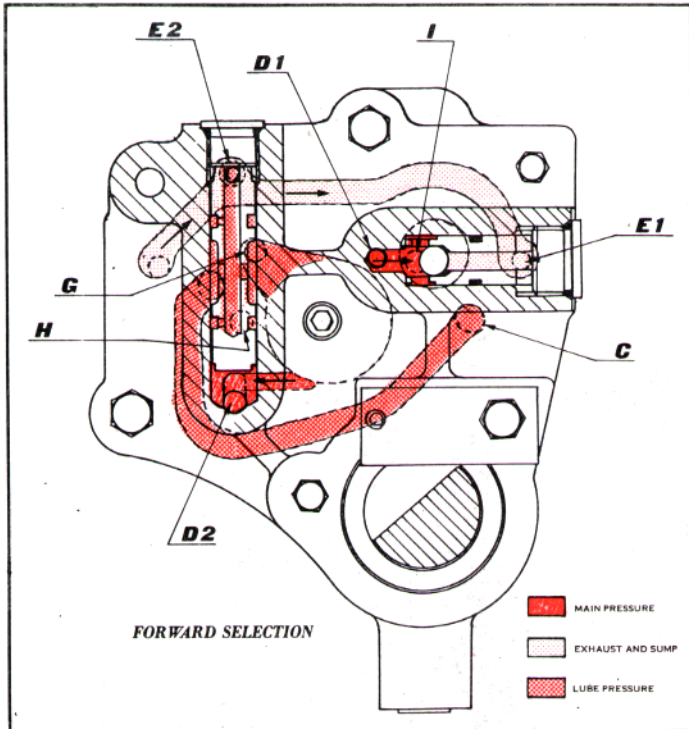

Figure 15-6. Control Valve - Forward - Sectional View.

Control Valve - Reverse.

See Figures 15-3, 15-7, 15-8.

When a shift to the reverse position is desired the control valve is moved away from the engine. The shift causes the control valve stem to rotate and assume the position indicated in Figure 15-7. The pressurized oil in chamber B is directed through port E which is interconnected with port E1 at high pressure shuttle valve, pushing the ball to opposite seat provided in valve body and closing the passage through port D. The pressurized oil travelling through port F reaches the rate-of-rise check valve; the rate-of-rise check valve meters the oil for a steady smooth pressure rise in chamber L through port K. As chamber L fills with oil, the rate of rise piston moves against the piston springs until the piston is stopped by a shoulder in the valve body. This causes the pressure in chamber B to rise to clutch engaging pressure. When in reverse passage D remains at atmospheric pressure since slot F remains open to sump. The pressurized oil from port E travels also through port E2 causing shift of lube shuttle

valve : this position of lube shuttle valve allows main flow of lube oil to travel through port H and partially through lube shuttle valve calibrated orifice to port G. When in reverse, passage D remains at atmospheric pressure since slot F remain open to sump when a shift is made from reverse to neutral the valve stem is rotated to the position illustrated by Figure 10-3. Under these conditions passage E being connected to sump by slot F, oil drains rapidly from the reverse clutch to sump. Since passage I is now at atmospheric pressure the oil pressure in chamber L unseats the plate orifice of rate-of-rise check valve against the compression spring permitting a rapid oil drain from chamber L to sump and allowing the pressure rate control piston to move back against the cam device from trolling stem. The reverse clutch is now disengaged and main system pressure reduced to neutral pressure.

Trolling Valve - Forward or Reverse.

See Figure 15-9.

When the trolling valve is to be used for either forward or reverse the cam/trolling lever is moved out of the detent position and into the trolling range (see Figure 15-10). With the cam/trolling lever out of the detent, the port K closes and the slot I gradually opens position (depending on trolling lever position), the oil pressure present in chamber L is drained to sump. The rate-of-rise piston position can be manually adjusted by the trolling lever to decrease the compression of the outer middle and inner springs against the high pressure regulator piston (see Figure 10-11), decreasing the pressure in high pressure regulator chamber B by routing the excess oil through the lube circuit of the engaged clutch (port C). This will cause the applied clutch to slip a percentage to hold the desired trolling speed.

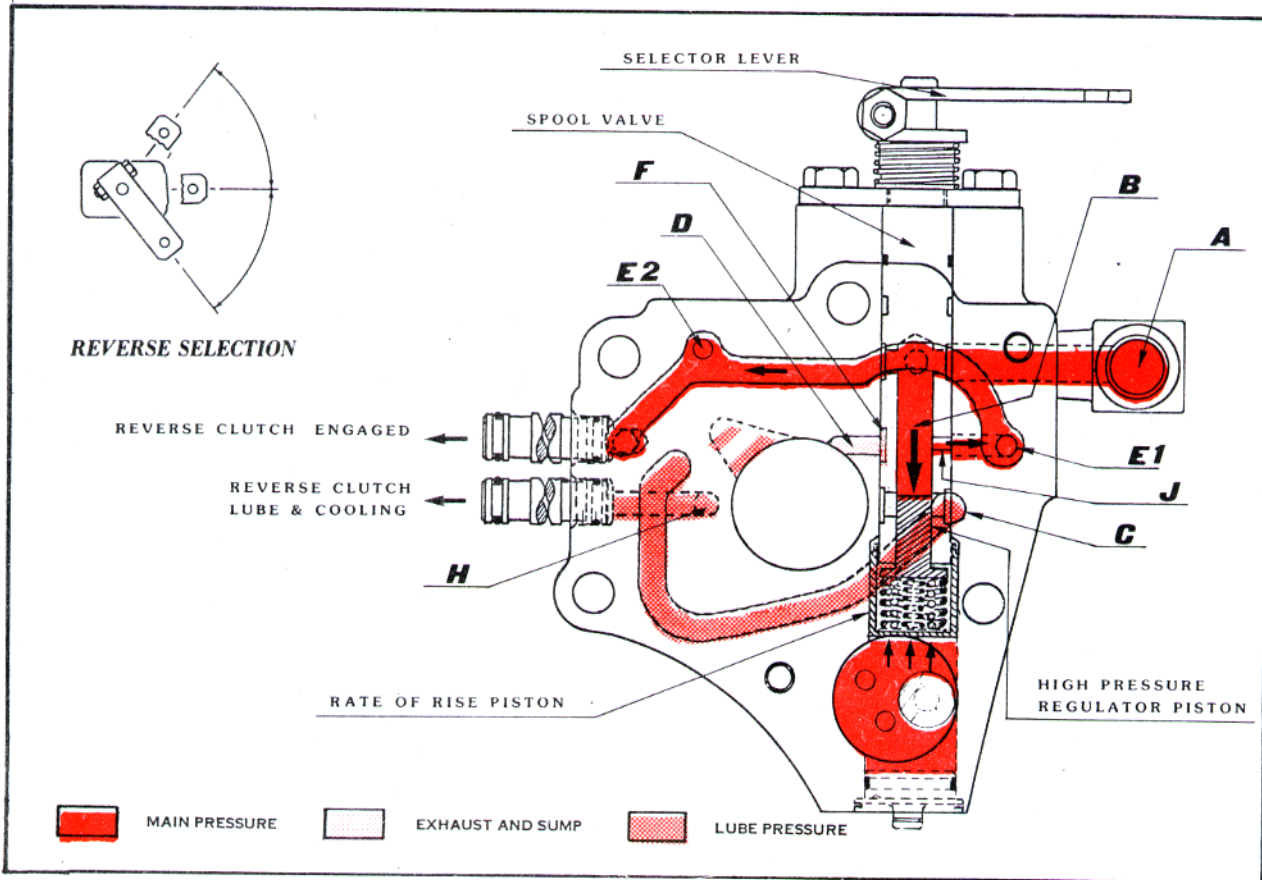

Figure 15-7. Control Valve - Reverse - Sectional View.

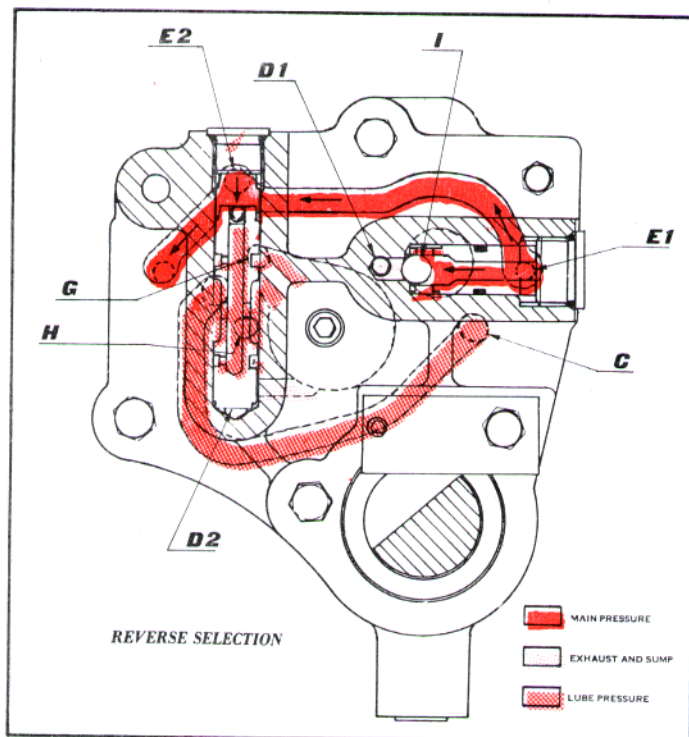

Figure 15-8. Control Valve - Reverse - Sectional View.

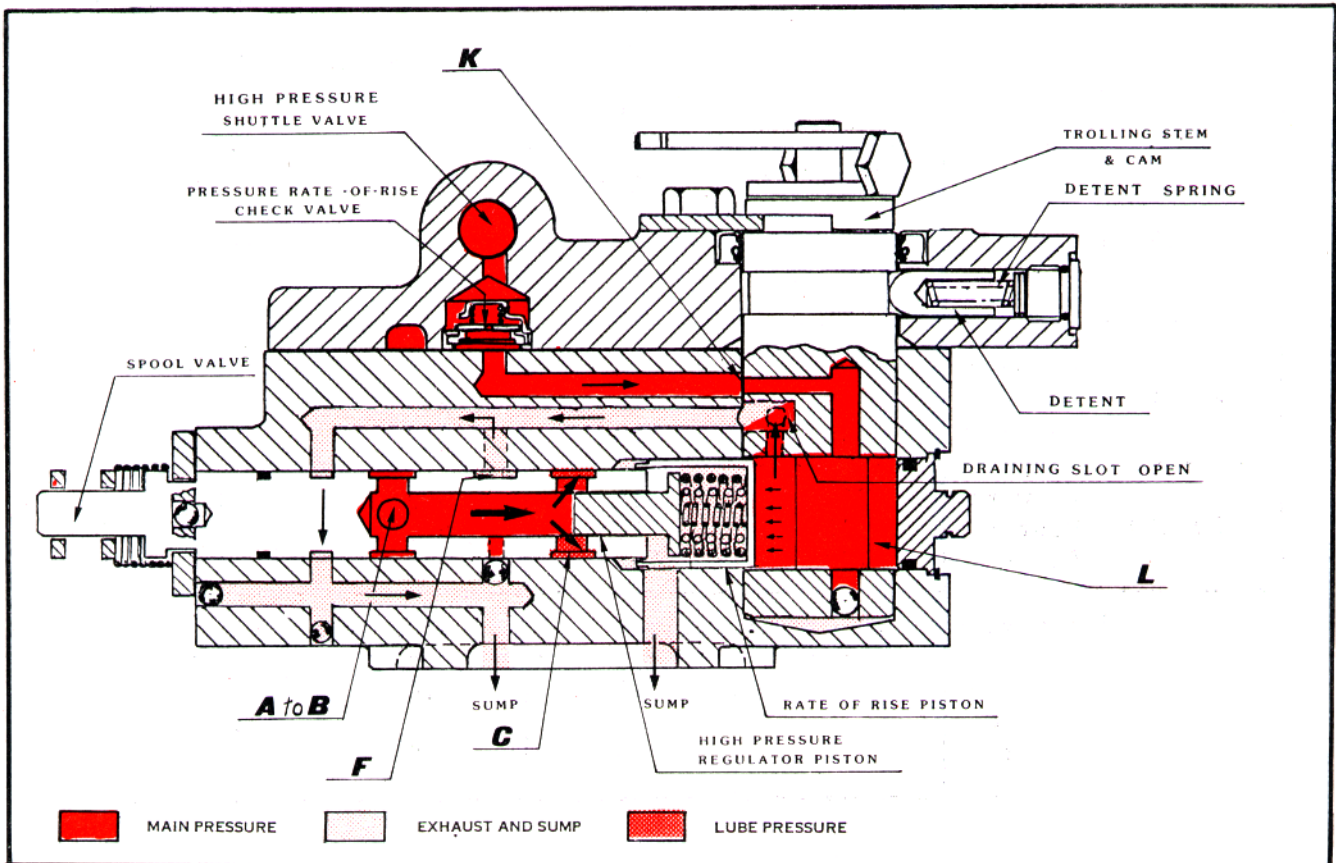

Figure 15-9 Control Valve and Trolling Valve - Cut-a-way View - Trolling Mode Function.

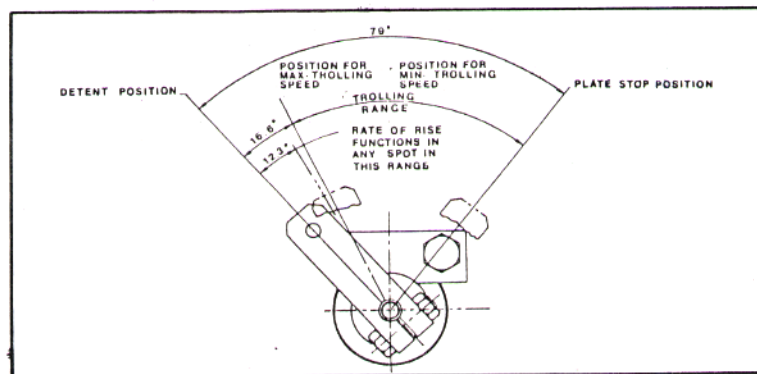

Figure 15-10. Trolling Lever Operating Range.

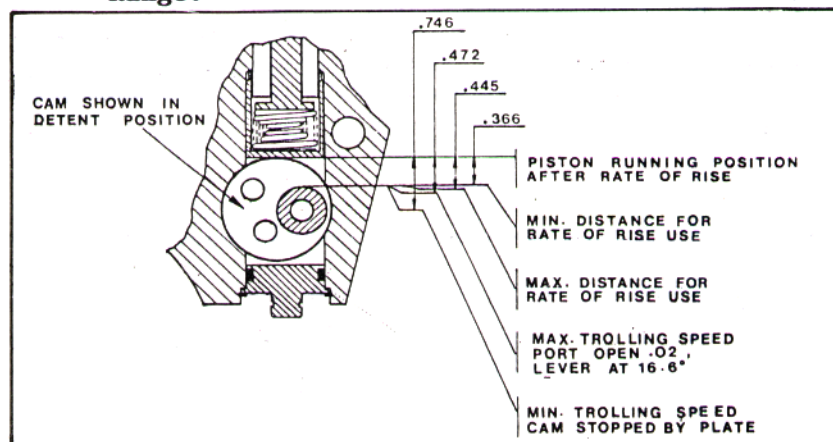

Figure 15-11. Trolling Cam Operating Range.



Limits with the standard 300 min. PSI springs.

TROLLING VALVE IN DETENTED POSITION					
INPUT RPM & SHIFT	Immediately Upstream of Shimmed Valve (X)		At End of Fwd Shaft Lube Circuit		
	Min. PSI A	Max. PSI B	Min. PSI C	Max. PSI D	
1800 RPM	Forward	300	320	7.5	16.5
	Neutral	80	120	2.0	16.5
	Reverse	300	320	2.0	4.0
600 RPM	Forward	280	315	0.8	4.0
	Neutral	70	110	0.2	4.0
	Reverse	280	315	0.2	1.0
Trolling valve with cam at minimum trolling stop position.					
1200 RPM	Forward	5	15	3.0	10
	Neutral			.8	10
	Reverse	5	15	.8	3

Limits with "special" 350 min. PSI springs.

TROLLING VALVE IN DETENTED POSITION					
INPUT RPM & SHIFT	Immediately Upstream of Shimmed Valve (X)		At End of Fwd Shaft Lube Circuit		
	Min. PSI A	Max. PSI B	Min. PSI C	Max. PSI D	
1800 RPM	Forward	350	370	7.5	16.5
	Neutral	80	130	2.0	16.5
	Reverse	350	370	2.0	4.0
600 RPM	Forward	330	365	0.8	4.0
	Neutral	70	120	0.2	4.0
	Reverse	330	365	0.2	1.0
Trolling valve with cam at minimum trolling stop position.					
735 RPM	Forward	5	15	1.5	6
	Neutral			.4	6
	Reverse	5	15	.4	1.5

A reading outside of limiting range could mean :

A wrong number of shims in valve, faulty valve springs, sticky valve, pump GPM too low, leakage, broken or forgotten seal rings.

CONTROL VALVE DISASSEMBLY.

1. Remove the control valve assembly (refer to Figure 15-12) and pump mount.
2. Loosen hex-nut (5) and remove shift lever (2) with spring compression (3) and washer (32).
3. Remove capscrews (30) and detent plate (6).
4. Remove valve spool (7), regulator piston (26), outer spring (24), inner spring (25).
5. Remove O-ring (8) from valve spool (7).
6. Loosen hex-nut (45) and remove lever shift (43).
7. Remove O-ring plug (46) with O-ring (47), detent spring (48), and detent (49) from the cover regulator (13).
8. Remove capscrews (14, 34, 35), cover (13) and gasket (12).
9. Remove the internal snap ring (20) and pull out the O-ring plug (21).
10. Remove the trolling stem (50) from the body valve (10) and the rate-of-rise piston (23).
11. Remove the O-ring plug (55, 19) with O-ring (54, 18) for removal of shuttle valve (52, 17) and ball (45) from the cover regulator.
12. Remove the check valve orifice (11) and discard the oil seal (41) from the cover regulator.

ASSEMBLY.

1. Install a new oil seal (41) on the cover regulator (13).
2. Install the shuttle valve (54) with

a new O-ring (16) and ball (15) into cover regulator. Close with the O-ring plug (19) with O-ring (18).

3. Install the shuttle valve (52) and close with O-ring plug (55) and O-ring (54).

4. Install the rate-of-rise piston (23) with outer spring (24) into the valve body (10) and press on piston with a screw drive to introduce the trolling stem into body (10).

5. Install the O-ring plug (21) with a new O-ring (22) and secure with the snap ring (20).

6. Install the check valve orifice (11) onto cover regulator (13) before to install it with a new gasket on body valve (10) and secure it with capscrews (14, 34, 35). Torque the capscrews 15 lbs. ft.

7. Install O-ring (8) onto valve spool (7).

8. Install valve spool (7), regulator piston (26) and inner spring (25) into the valve body (10).

9. Install detent plate (6) and secure it with capscrew (30). Torque the capscrews 15 + 2 lbs. ft.

10. Install shift lever (2) with spring compression (3) and washer (32) onto the valve spool (7) and secure with capscrews (1) and hex-nut (5) and washer (4).

11. Install the detent (49) into the threaded hole of the cover regulator (13) making certain that the detent fills into the detent recess of the trolling stem.

12. Install spring (48) and O-ring plug (46) with O-ring (47) into the threaded hole of the cover regulator (13).

13. Install the lock plate (39) into the slot of the trolling stem and onto the



roll pin (40). Fit and secure the shift lever (43) with capscrew (42), washer (44) and hex nut (45).

INSTALLATION. (Field)

Selector Valve.

1. Remove the selector valve (refer to Figure 12) assembly and pump mount. Remove the pump outlet to heat exchanger inlet oil line at the pump outlet only. Then remove heat exchanger outlet to valve inlet oil line from selector valve assembly, high pressure inlet only.

2. Remove hydraulic pump by removing the four screws which fasten it to the pump mount. These screws will be reused.

3. Remove three 3/8 hex-head capscrews from pump mount which **will be** reused.

4. Remove three 3/8 hex-head capscrews from main regulator valve body, which **will not** be reused.

5. Remove selector valve assembly, pump mount, and connector tubes by sliding them to the rear until they come off the forward and reverse clutch shaft simultaneously. It may be necessary to uncouple the marine transmission flange from the companion flange and move both flanges to the rear to permit this assembly to be removed.

TROLLING VALVE.

1. Install the trolling valve assembly. Assemble four new O-rings removed from 8-1/2 x 11 plastic bag, to the two jumper tubes.

2. With the old shim pack installed over the pilot diameter of the old selector valve assembly, measure the pilot face to top of shim distance, using a depth micrometer.

3. Remove three 3/8 hex nuts holding nine shims to the trolling valve assembly pilot face.

4. Select a combination of new shims to get the same pilot face to top of shim distance for the trolling valve assembly as for the old selector valve assembly. Recheck this distance with depth micrometer with the selected shim pack placed over the pilot diameter on the trolling valve. The pilot face to top of shim distance must be the same for the new trolling valve assembly as it was for the old selector valve assembly to assure the same forward clutch shaft bearing endplay.

5. Clean mating surfaces of the new trolling valve assembly, pump mount, shims, and rear cover and apply anaerobic sealant to the shims, the face of the pump mount and the trolling valve face.

6. Assemble pump mount with its shim pack, jumper tubes, and new trolling valve assembly with its shim pack. Then slide this assembly onto the forward and reverse clutch shafts, simultaneously.

7. Install three new 3/8 hex-head capscrews into the new trolling valve assembly and the rear cover, and install three **used** 3/8 hex-head screws into the pump mount and rear cover. Tighten these capscrews to 27-30 lbs. ft. torque.

8. Reinstall the hydraulic pump making certain that the pump drive tang engages the shaft drive slot. Torque the screws to 15-17 lbs. ft.

9. Reinstall the oil line from the pump outlet to the heat exchanger inlet.

10. Mount the filter assembly supplied with the trolling valve parts. Two thinwall pipe plugs from filter inlet and outlet and one thinwall pipe plug from new trolling valve assembly high pressure oil inlet, 90 degree elbow must be removed and discarded.

11. Connect oil line from the heat exchanger outlet to filter assembly inlet, located on the side of the filter. The oil line that was used to connect the heat exchanger discharge to the old selector valve inlet may be suitable.

12. Connect the filter assembly outlet

to new trolling valve assembly high pressure inlet with hydraulic flexible hose or tubing. Hydraulic hoses, tubing, and fittings needed to connect the filter to the heat exchanger and to the trolling valve assembly are not supplied by Twin Disc. Hydraulic lines must withstand 450 psi continuously.

SELECTOR VALVE, RATE OF RISE & TROLLING CONT.

ITEM	DESCRIPTION	QUANTITY	ITEM	DESCRIPTION	QUANTITY
1	CAPSCREW, hex-head (1/4-20x1)	1	30	CAPSCREW, hex-head (5/16-18x3/4)	2
2	LEVER, shift	1	31	BALL, steel	1
3	SPRING, compression	1	32	WASHER, steel	1
4	WASHER	1	33	CAPSCREW, hex head (M10x1.5x95)	2
5	NUT (1/4-20)	1	34	CAPSCREW, hex head (5/16-18x1-1/2)	1
6	PLATE, detent (not serv. sep.)	1	35	CAPSCREW, hex-head (5/16-18x1-3/4)	1
7	STEM, valve	1	36	PLUG, pipe (1/8-27 NPTF)	1
8	'O' RING	1	37	CAPSCREW	1
9	ELBOW, street 90°, 3/8-18	1	38	WASHER, steel	1
10	BODY, main regulator valve (not serv. sep.)	1	39	PLATE, lock	1
11	VALVE, check orifice	1	40	PIN, roll	1
12	GASKET, valve cover	1	41	OIL SEAL	1
13	COVER, regulator valve	1	42	CAPSCREW, hex-head (1/4-20x1)	1
14	CAPSCREW, hex-head (5/16-18x1)	1	43	LEVER, shift	1
15	BALL, steel	1	44	WASHER	1
16	'O' RING	1	45	NUT (1/4-20)	1
17	VALVE, shuttle	1	46	PLUG, pipe (1/4 inch)	1
18	'O' RING	1	47	'O' RING	1
19	PLUG (3/4-16)	1	48	SPRING, detent, indexing	1
20	RING, internal snap	1	48 A	SHIM	as req'd
21	PLUG	1	49	DETENT, indexing	1
22	'O' RING	1	50	STEM, trolling (not serv. sep.)	1
23	PISTON, pressure rise	1	51	BALL, steel	2
24	SPRING, compression, outer	1	52	VALVE, shuttle	1
24 A	SHIM	as req'd	53	BALL (not serv. sep.)	2
25	SPRING, compression, inner	1	54	'O' RING	1
26	PISTON, regulator	1	55	PLUG	1
27	SHIM	as req'd			
28	BALL, steel	2			
29	BALL, steel	6			

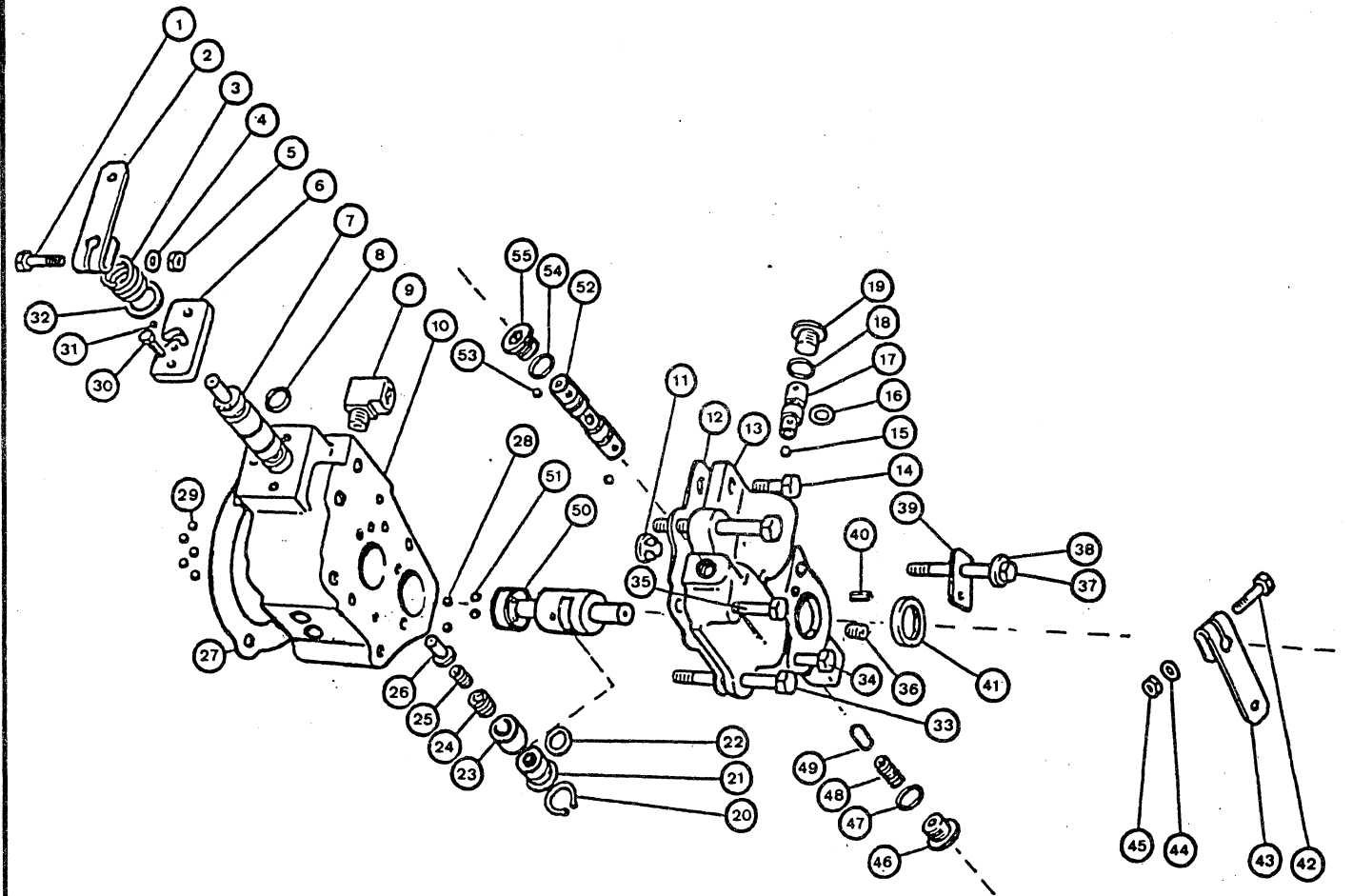

Control Valve and Trolling Valve – Exploded View. Figure 15-12

1-PX-6452-A CONSISTS OF:

- 1-P-6452
- 1-P-5074-A
- 1-PM-5147-A
- 2-M-1990-C
- 1-MA-670

- 2-PM-3589-AS
- 2-P-5068
- 2-A-2916-FG
- SEE CHART
- 2-PM-5077

- 2-M-5108-A
- 2-P-5083

- 14-P-3924-C
- 12-P-3929
- 2-P-5082
- 2-P-5070
- 2-A-2959-K
- 1-P-5732
- 2-P-5141

1-PX-6451-A CONSISTS OF:

- 1-P-6451
- 1-P-5071-A
- 1-PM-5127-A
- 2-M-1990-C
- 1-MA-670

- 1-P-5662
- SEE CHART
- 2-P-5146
- 1-PM-5471
- 1-B-6134
- 1-P-5117-C
- 1-PM-5728
- 1-P-5088-B
- 2-PM-5731-A
- 1-PM-5729-A

- 1-PM-6173
- P-5710 AS
- 1-P-5710-A REQ'D
- 1-P-5710-B
- 2-PM-1357-F
- 1-PM-5076
- 5-PM-4037-B
- 1-P-5089-A

SEE CHART
SEE CHART

1-P-5103

- THIS UNIT CANNOT BE USED WITH LEFT HAND ENGINE
- MAX SPEED 3200 R.P.M.

* OPTIONAL

NOT SERVICEABLE AS A SEPARATE ITEM

REVISION	DATE	BY	CHKD	DATE	BY
G	3843	12 APR 82	HD		
F	3784	11 OCT 82	V.R.		
E	3773	8 OCT 82	42		
D	3762	24 AUG 82	RT		
C	3751	23 AUG 82	42		
B	3552	14 MAY 81	J.D.		
A	3543	24 APR 81	J.D.		

SAE No	SPIDER No	D. RING No	ADAPTOR No	SCREWS No	R. BLOCKS No	RATIO.
1	P-5116-D	215041	1-P-4203 1-P-5083-E	10-PM-1357-A 12-M-2008-U	26-A-3905-B 26-A-3905-E	2.99:1 1.98:1
2	P-5110-E	A 6816-E	P-50C3-B	10-PM-1357-A	20-A-3905-E	
3	P-5112-E	H-6516-E	P-5084-C	10-PM-1357-A	20-A-3905-E	

NAME PLATE NUMBER	PINION CLUTCH HUB (2 REQUIRED)				GEAR-OUTPUT SHAFT (1 REQUIRED)				
	ASSEMBLY NUMBER	CONSISTS OF (BUSHING, PM-5009 & PINION No)	NUMBER OF TEETH	RATIO OVERALL	HELIX HAND	PART NUMBER	NUMBER OF TEETH	RATIO	HELIX HAND
	PX-6530A	P-6530A	24	2.99:1	RIGHT	P-5099	68	2.99:1	LEFT
	PX-6531A	P-6531A	27	2.54:1	RIGHT	P-5094	65	2.54:1	LEFT
	PX-5126A	P-5117A	32	1.98:1	RIGHT	P-5104	60	1.98:1	LEFT
	PX-5125A	P-5121A	37	1.51:1	RIGHT	P-5106	53	1.51:1	LEFT
	PX-5124A	P-5123A	44	1.10:1	RIGHT	P-5107	46	1.10:1	LEFT

SECTION B-B

SECTION A-A

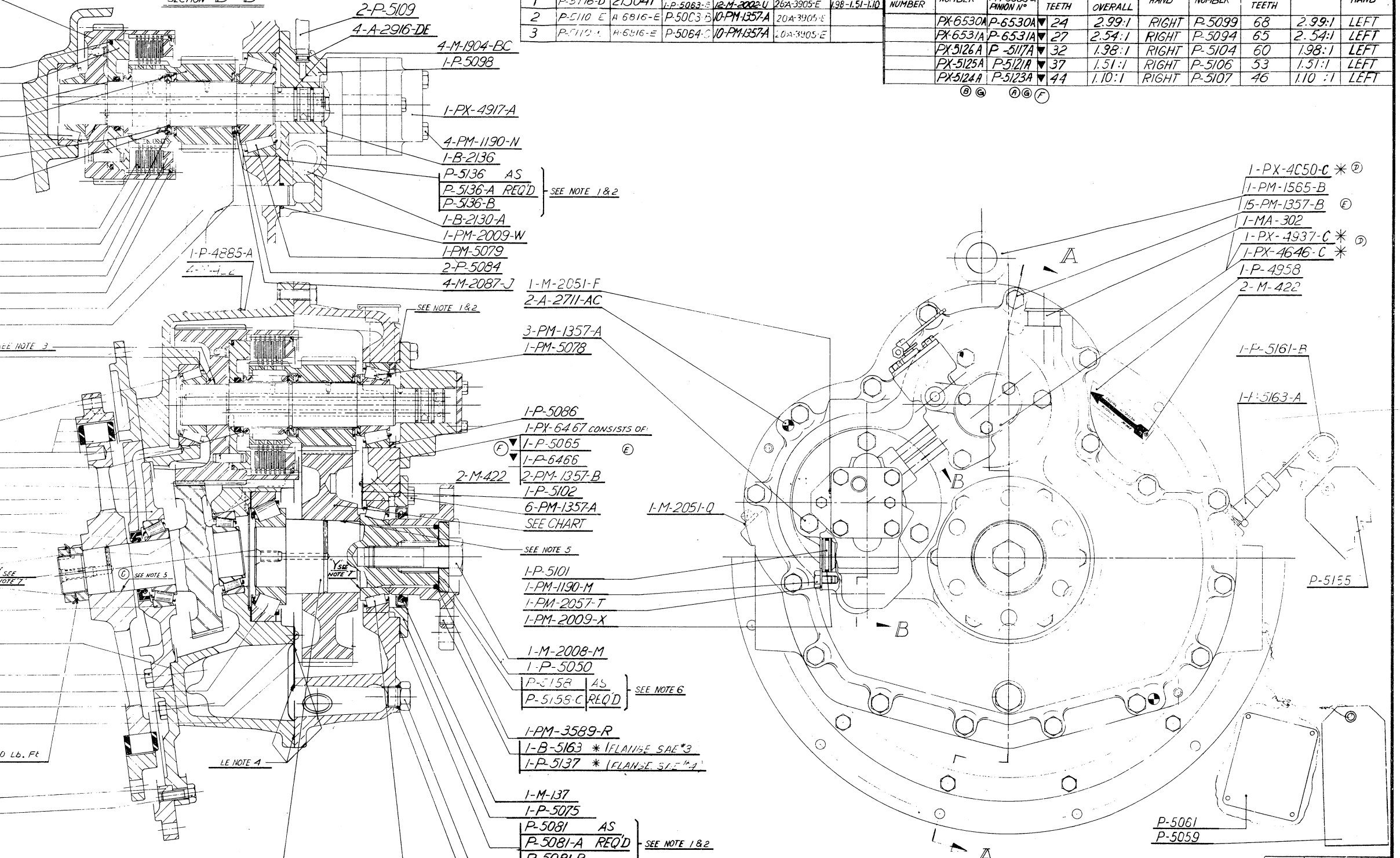

MARINE TRANSMISSION
MODEL MG-502A

- ASSEMBLY INSTRUCTIONS:
- SHIM SEALING: DEGREASE THEN APPLY ANAEROBIC SEALANT ONLY IN THE CAVITY FORMED BY THE INSIDE DIA. OF THE SHIMS, THE RETAINER AND ITS PLOTT DIA., AND THE MATING PART (S-774)
 - ASSEMBLE AND TEST PER S-570-S AND B2408 G
 - FORWARD AND REVERSE GEARS MUST BE HEATED 180°F MAX. AND SHAFTS COOLED TO 40°F MIN FOR ASSEMBLY
 - DEGREASE BOTH FACES AND APPLY ANAEROBIC PLASTIC GASKET COMPOUND PER S774
 - TO DISASSEMBLE, INJECT AIR BY GREASE OR OIL PRESSURE. A CLAMP PLATE MAINTAINED AT .25 CLEARANCE MUST BE USED TO AVOID PROJECTION OF PARTS.
 - SHIM ON SHAFT END TO OBTAIN .002-.003 CLEARANCE BETWEEN SHIMS AND CLAMP PLATE.
 - PROSE ADJUSTABLE GEAR ON SPIDER END ALIGN WITH SHAFTS FACE MARKER
 - SEE PARTS LIST FOR DIMENSIONS & FITS.
 - APPLY ANAEROBIC SEALANT ONLY AS SHOWN ON DRAWING PB-2607

DIMENSIONAL TOLERANCE UNLESS SPECIFIED
MACHINED SURFACES ± .01
ANGULAR LOCATION ± .005
ANGULAR LOCATION SURFACES DRILLED HOLES ± .03
MACHINED ANGLES ± 2° EXCEPT CHAMFER
CAMMING FINISH: MIN. MAX.

SHEET 1 OF 2	CROSS SECTION WITH PART NUMBERS
SHEET 2 OF 2	INSTALLATION DRAWING
P-5245	HYDRAULIC SYSTEM
P-5244	MASS ELASTIC SYSTEM

SURFACE TREATMENT	MATERIAL	HEAT TREAT	FIRST USE
DATE: 20 MAY 82	SCALE: 1/2"	DRAWN: RZ	CHECKED: J
MODEL: MG-502A		APPROVED: [Signature]	

TWIN DISC INTERNATIONAL
Soudré, Belgium
NIVELLES - BELGIUM
PX-6470
SHEET 1 OF 2

SAE N°	A	B	C	D	E	F	G	H	I	J	K	L	M	N	P	Q	R	S	T	U	V	W		
1	21.75	20.800	20.125	18.375	17.255	-	.50	1.00	2.74	12.71	-	14.26	16.85	.25	.58	1.91	12.95	13.01	16.67	11.98	4.79	.35	.28	1.18
2	18.25	18.300	17.625	13.875	13.130	12.226	.75	1.56	2.18	12.15	.39	13.70	16.39	.25	.58	2.47	12.39	12.45	16.11	11.40	4.23	.35	.28	1.18
3	17.75	16.990	16.125	13.875	13.130	12.226	.75	1.56	2.18	12.15	.38	13.70	16.39	.25	.38	2.47	12.39	12.45	16.11	11.40	4.23	.35	.28	1.18

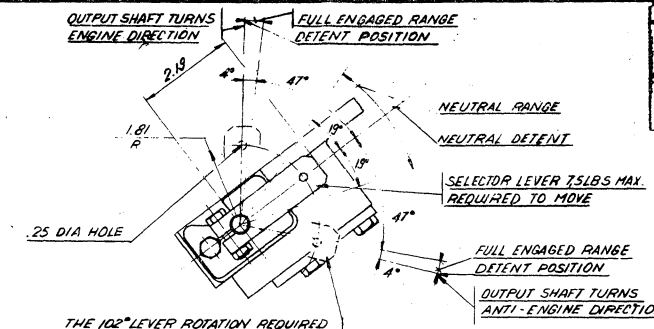

H.E. INSTALLATION & SERVICE REQUIREMENTS
 ON LINE TRANSMISSION TO H.E. AND RETURN -----
 1) MAX. VELOCITY IN FITTING PIPE, HOSE AND TUBES 25 FT/SEC.
 2) MAX. PRESSURE MIN = 10" PEAK OIL PRESSURE AT H.E.
 3) H.E. & TUBING MUST BE PROTECTED FROM MECHANICAL DAMAGE. ZINC ANODES
 4) PROTECT LINES FROM MECHANICAL DAMAGE. ZINC ANODES
 5) PROTECT H.E. RAW WATER PASSAGES FROM CORROSION.
 CHECK & REPLACE THEM FREQUENTLY.

HEAT EXCHANGER (H.E.) REQUIREMENTS
 PERMISSIBLE TEMPERATURE INTO H.E. 200°F MAX. (200°F MIN. FOR FRESH WATER)
 PERMISSIBLE TEMPERATURE OUT OF H.E. 180°F MAX. (180°F MIN. FOR FRESH WATER)
 MULTIPLY BY 1.25 FOR FRESH WATER
 CONTINUOUS DUTY
 APPROX. OIL FLOW TO H.E. 10 GPM PER HOUR ENGINE R.P.M.
 PEAK OIL PRESSURE AT H.E. (PROTECTED H.E. AT 15:1 RATIO) 300 PSI
 MAX. ALLOWABLE OIL PRESSURE DROP ACROSS H.E. WITH 300 SUS OIL AT RATED ENGINE R.P.M. 30 PSI.
 WATER FLOW TO H.E. USE 1.5 TO 3.0 TIMES OIL GPM
 HE WATER PRESSURE RATING, MIN. = 15" H.E. INLET WATER PSI.
 DATA H.E. PURCHASER MUST ALSO TELL VENDOR
 STATE IF RAW (OPEN CHANNEL & SEA) OR FRESH (CLOSED ENGINE JACKET & KEEL COOLER) WATER WILL COOL H.E.
 STATE MAX. WATER TEMP INTO H.E. - TYPICAL - RAW WATER - 85°F, KEEL COOLER WATER - 140°F ENGINE JACKET WATER - 180°F
 STATE MIN. ALSO MAX. GPM OF WATER FLOW TO H.E.

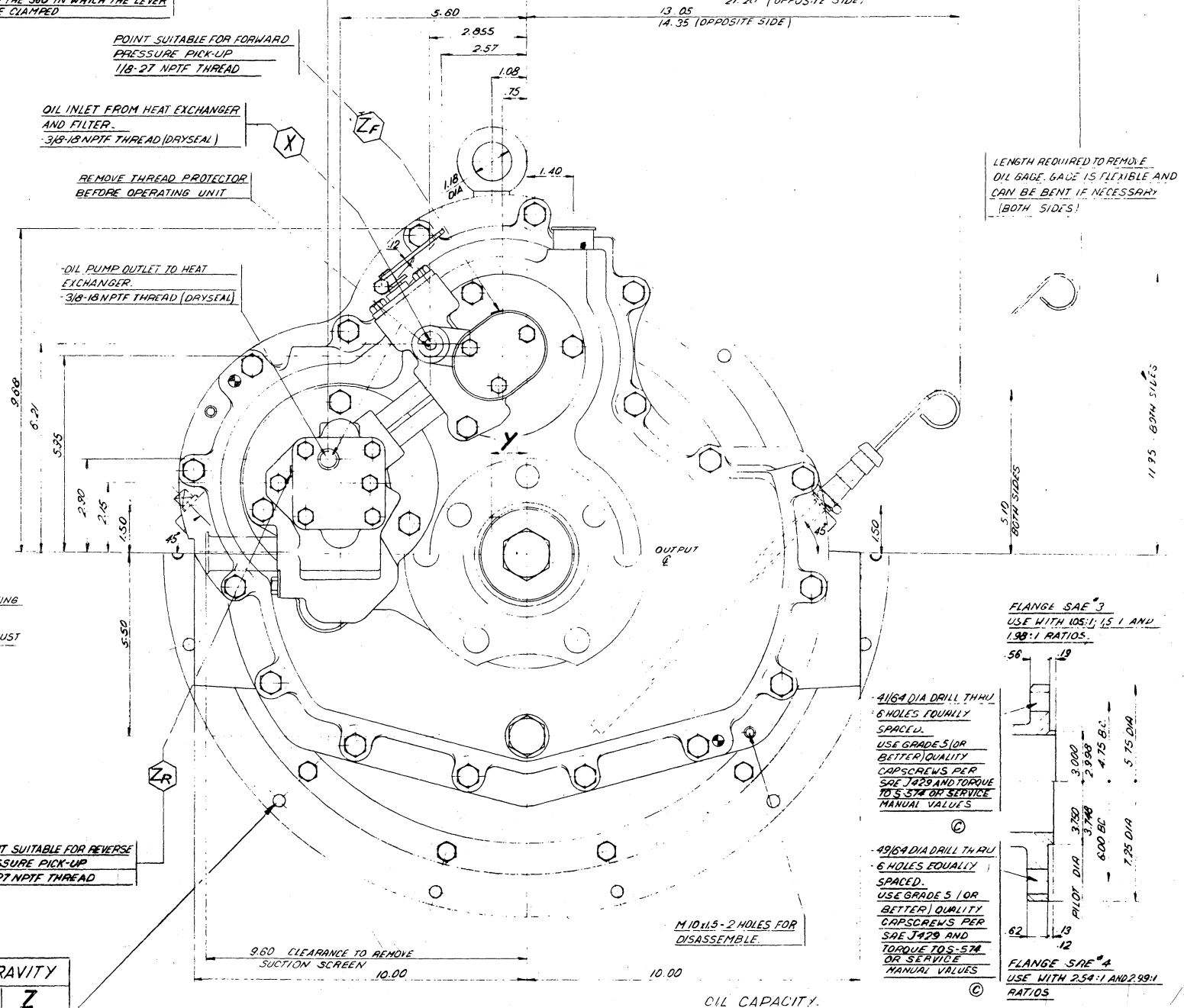
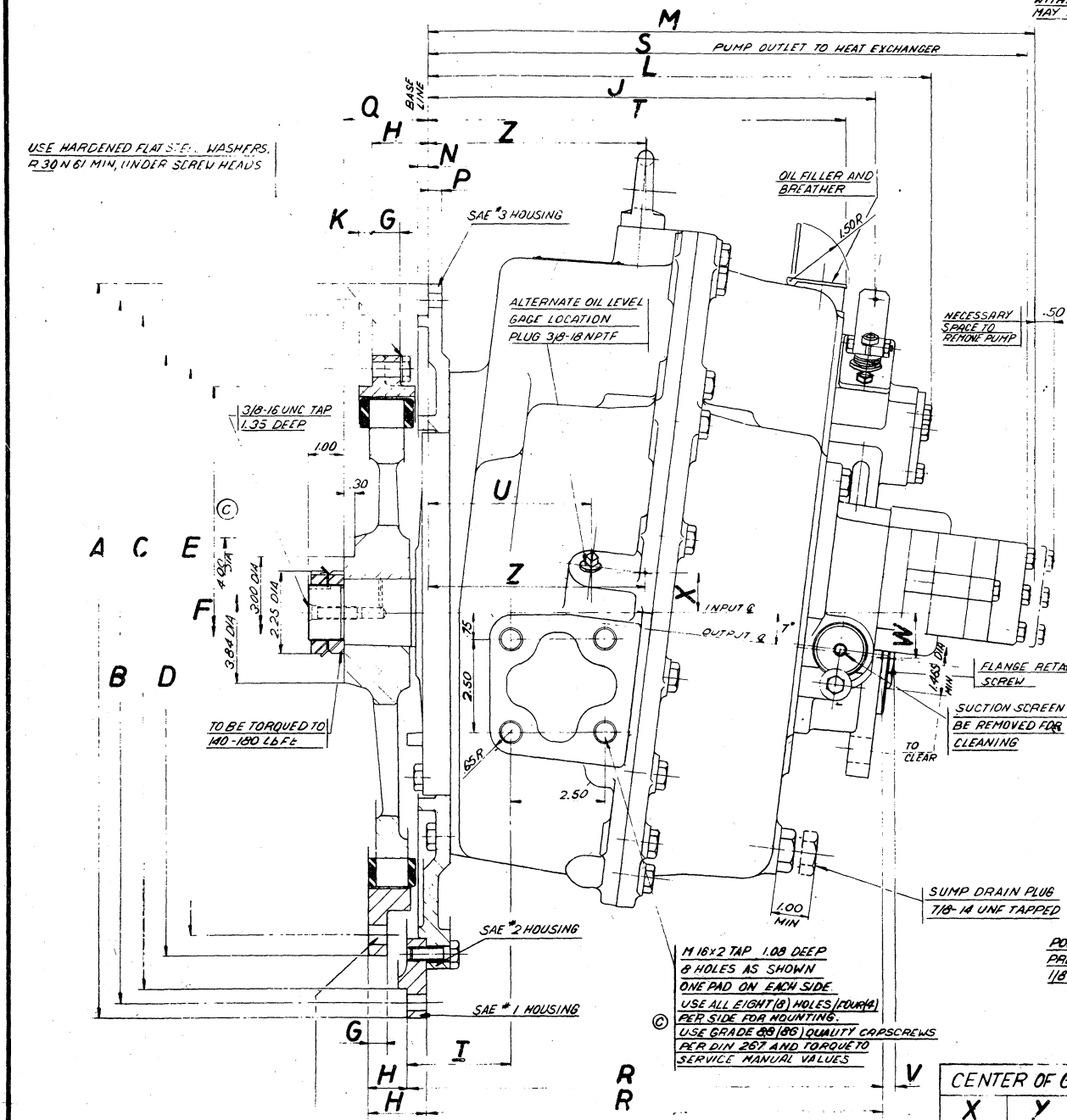

USE HARDENED FLAT STEEL WASHERS, R.30 N 61 MIN, UNDER SCREW HEADS

THE 102° LEVER ROTATION REQUIRED FOR CONTROL MAY FALL ANYWHERE WITHIN THE 360° IN WHICH THE LEVER MAY BE CLAMPED

LENGTH REQUIRED TO REMOVE OIL GAGE. GAGE IS FLEXIBLE AND CAN BE BENT IF NECESSARY BOTH SIDES!

FLYING RING
 SAE #1 - 17/32 DIA DRILL THRU - 8 HOLES EQUALLY SPACED AS SHOWN
 SAE #2 - 13/32 DIA DRILL THRU - 8 HOLES EQUALLY SPACED AS SHOWN
 USE GRADE 5 OR BETTER QUALITY CAPSCREWS PER SAE J429 AND TORQUE TO S574 OR SERVICE MANUAL VALUES.

CENTER OF GRAVITY		
X	Y	Z
1.12	1.08	5.95

ADAPTORS
 SAE #1 - 15/32 DIA DRILL THRU - 12 HOLES EQUALLY SPACED AS SHOWN
 SAE #2 - 13/32 DIA DRILL THRU - 12 HOLES EQUALLY SPACED AS SHOWN
 SAE #3 - 13/32 DIA DRILL THRU - 11 HOLES EQUALLY SPACED AS SHOWN
 USE GRADE 5 OR BETTER QUALITY CAPSCREWS PER SAE J429 AND TORQUE TO S574 OR SERVICE MANUAL VALUES.

OIL CAPACITY WITHOUT HEAT EXCHANGER
 DIMENSIONAL TOLERANCE UNLESS SPECIFIED
 MACHINED SURFACES ± .01
 ANGULAR LOCATION OF DRILLED HOLES ± .005
 ANGULAR LOCATION BETWEEN CIRCLES DRILLED HOLES ± .03
 MACHINED SURFACES ± .2" EXCEPT CHAMFERS
 CHAMFER FINISH: MIN. MAX.

SHEET	CROSS SECTION WITH PART NUMBERS
1 OF 2	1 OF 2
2 OF 2	2 OF 2
P-5245	HYDRAULIC SYSTEM
P-5249	MASS ELASTIC SYSTEM

MARINE TRANSMISSION
MODEL: M6 507 A

IMPORTANT NOTICE!
 THE SPACE NECESSARY FOR ADEQUATE SERVICING ACCESS AND FOR REMOVAL AND RE-INSTALLATION OF THIS PRODUCT IS INDICATED ON THIS DRAWING TO ENABLE DESIGNERS TO PLAN THE SPACE NECESSARY FOR INSTALLATION. BUT IT SHOULD BE NOTED THAT THE USER OF AN WARRANTY CLAIM, TWIN DISC MUST MAINTAIN ANY LIABILITY FOR COSTS INCURRED IN REMOVAL AND RE-INSTALLATION.

MATERIAL	HEAT TREAT	TWIN DISC INTERNATIONAL
SURFACE TREATMENT	FIRST USE	DATE 12 MAY 88
WEIGHT	ASSEMBLY No.	SCALE 1/2" = 1"
ROUGH FINISHED	MODEL No.	DRAWN BY
	NAME	CHECKED BY
	MODEL M6 507A	APPROVED
		PX-6470
		SHEET 2 OF 2

