

NOTE:
TO INSURE NO PRELOAD ON SHIFTING
MECHANISM. HAND LEVER POSITION SHOULD
BE SLIGHTLY PAST VERTICAL POSITION OR
TOWARDS ENGINE.

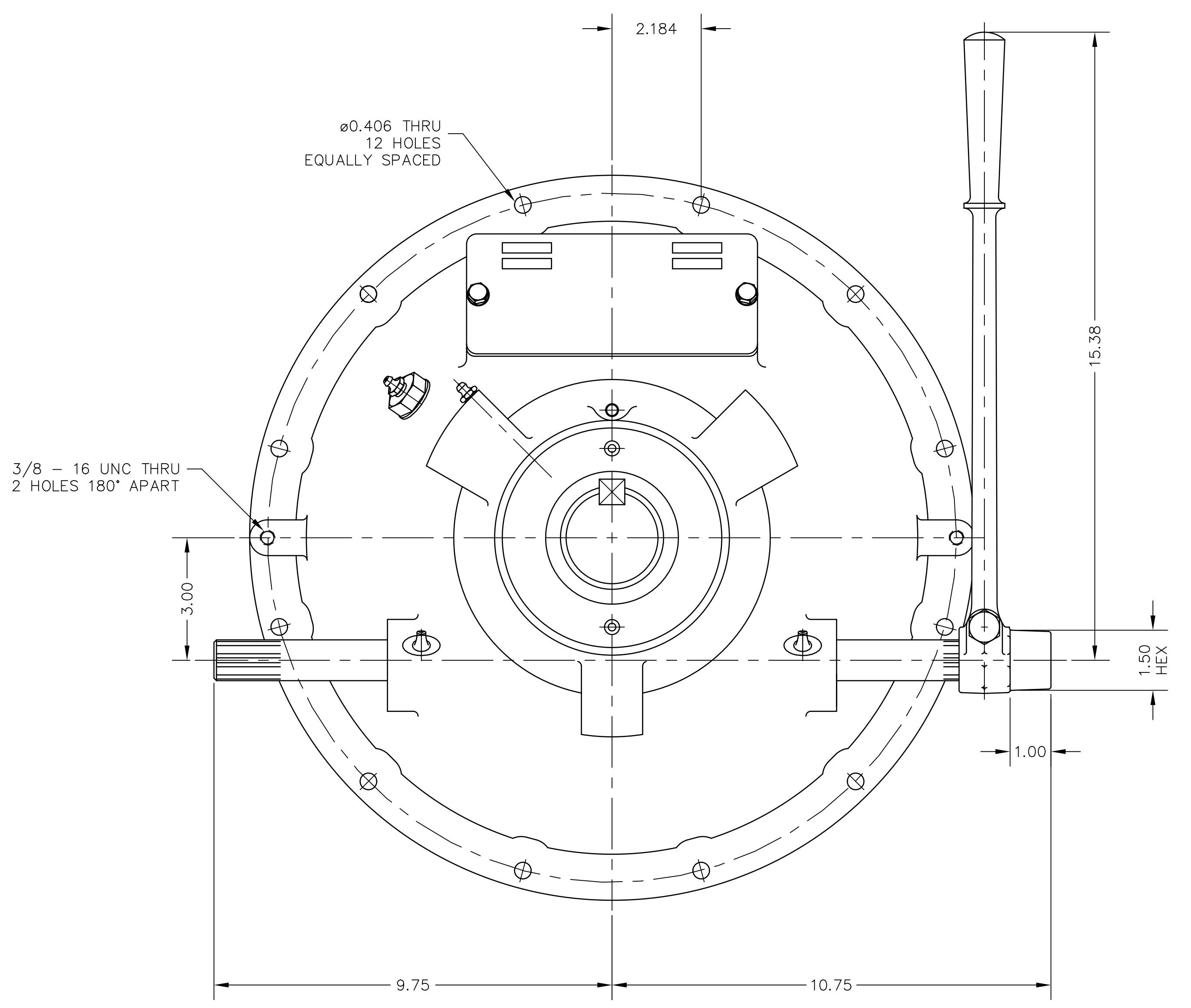
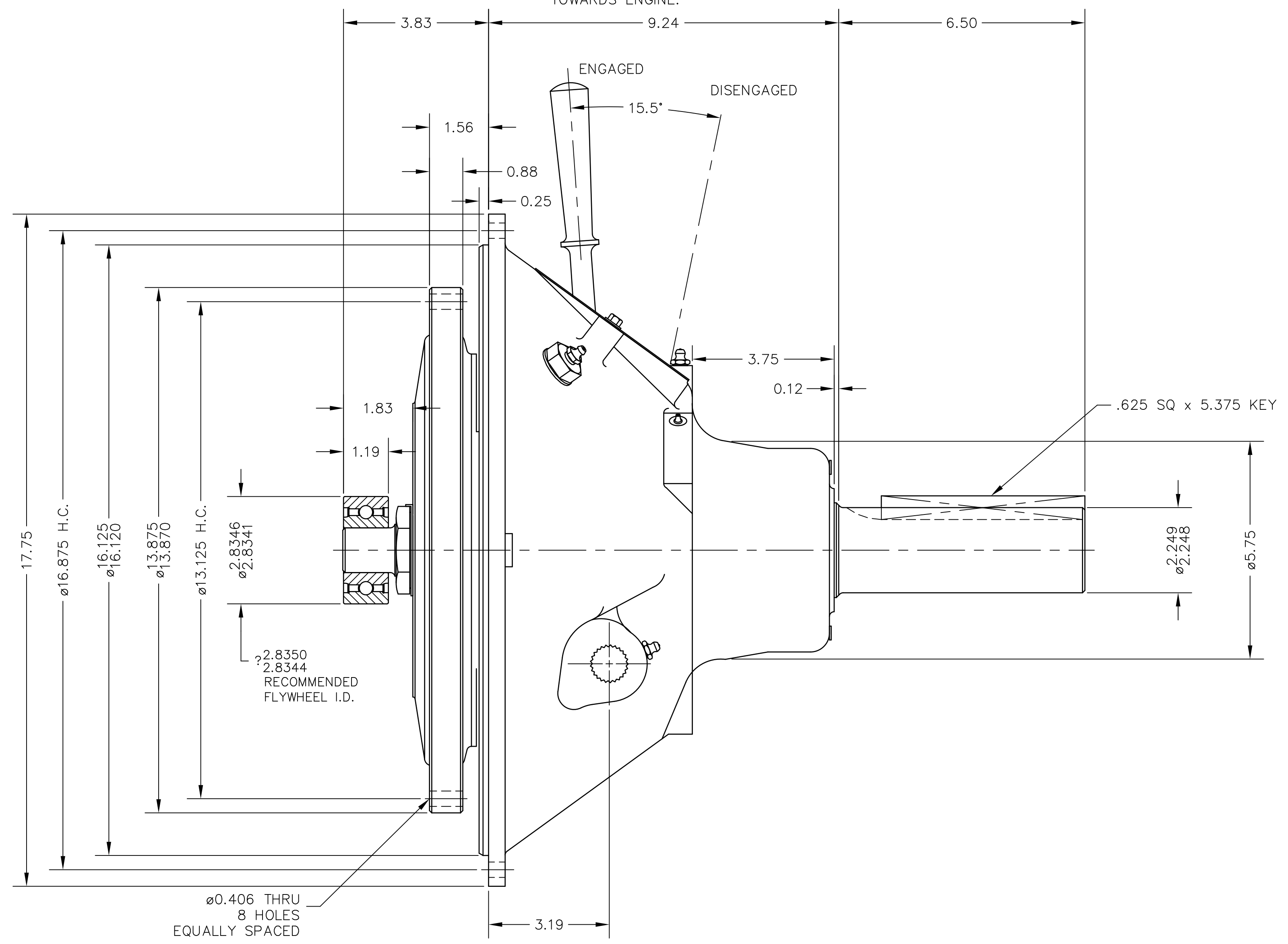

GENERAL NOTES:
a.) REFER TO BILL OF MATERIAL WHEN ORDERING PARTS.
b.) REFER TO CARE & OPERATION MANUAL FOR ADDITIONAL INFO.

UNLESS OTHERWISE SPECIFIED MACHINED DIMENSIONS X.X ±0.030 X.XX ±0.010 X.XXX ±0.005 ALL ANGULAR TOLERANCES ±1° GEOMETRIC TOLERANCING PER ASME Y14.5M 1994.	WEIGHT	WR ²	FIRST USE	INCH	MATERIAL	HEAT TREAT	DATE	TWIN DISC INCORPORATED RACINE, WI 53403 - USA	
	LBS.	LBS./IN ²	ASSY. SP111P340 MODEL SP111HP3				08-14-14		
NOTICE: THIS PRINT CONTAINS PROPRIETARY INFORMATION AND IS NOT TO BE USED IN ANY MANNER DETRIMENTAL TO THE INTEREST OF TWIN DISC, INCORPORATE THIS NOTICE IS NOT INTENDED TO NULLIFY OR LIMIT RIGHTS GRANTED TO THE U.S. GOVERNMENT OR OTHERS BY CONTRACT.				THIRD ANGLE PROJECTION	SIMILAR TO	NAME	SCALE	SP111P340	
					SP111P326	SP111HP3 POWER TAKE-OFF	.38 = 1		
							DRN:	DWG	REV -
							CHK:	SIZE	
							APPR:	SHT	2 OF 2
							DAJ	A	

F I E I D I B I A