

***For Your Convenience: This Northern
Lights File Is Shared By Diesel Parts Direct***



YOUR ONE STOP SUPERSTORE FOR DIESEL ENGINE PARTS

SHOP NOW

Service Side

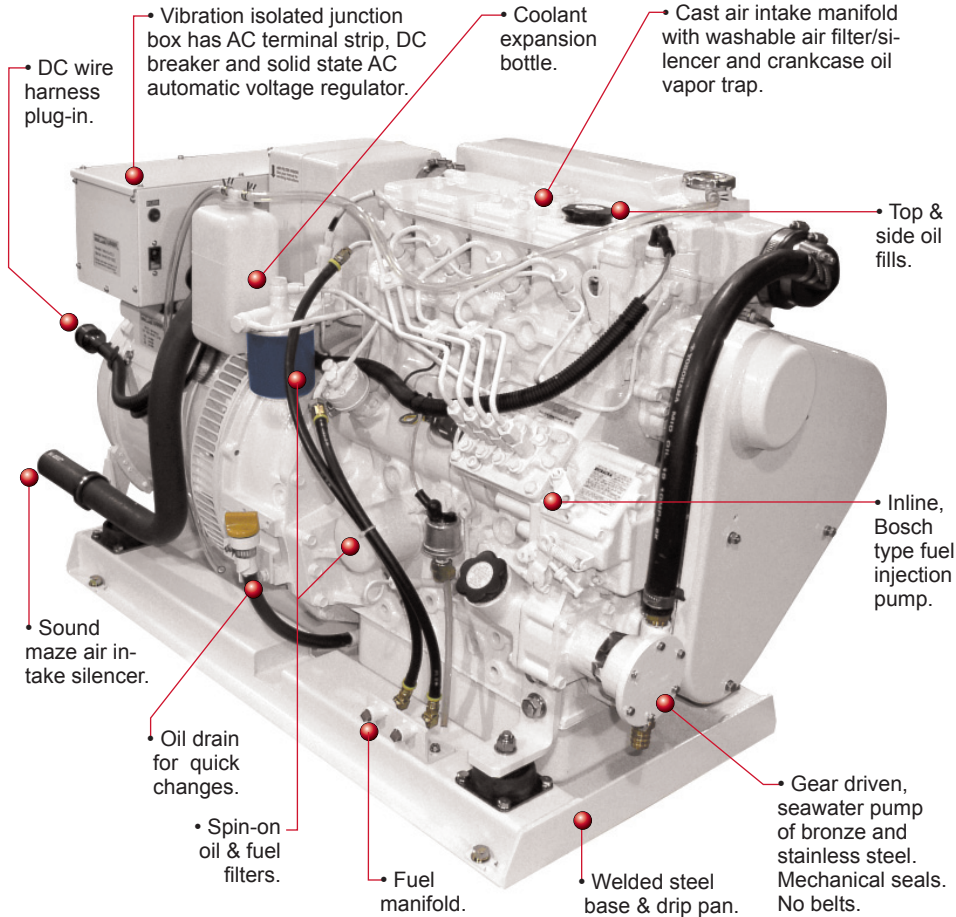

Non-Service Side

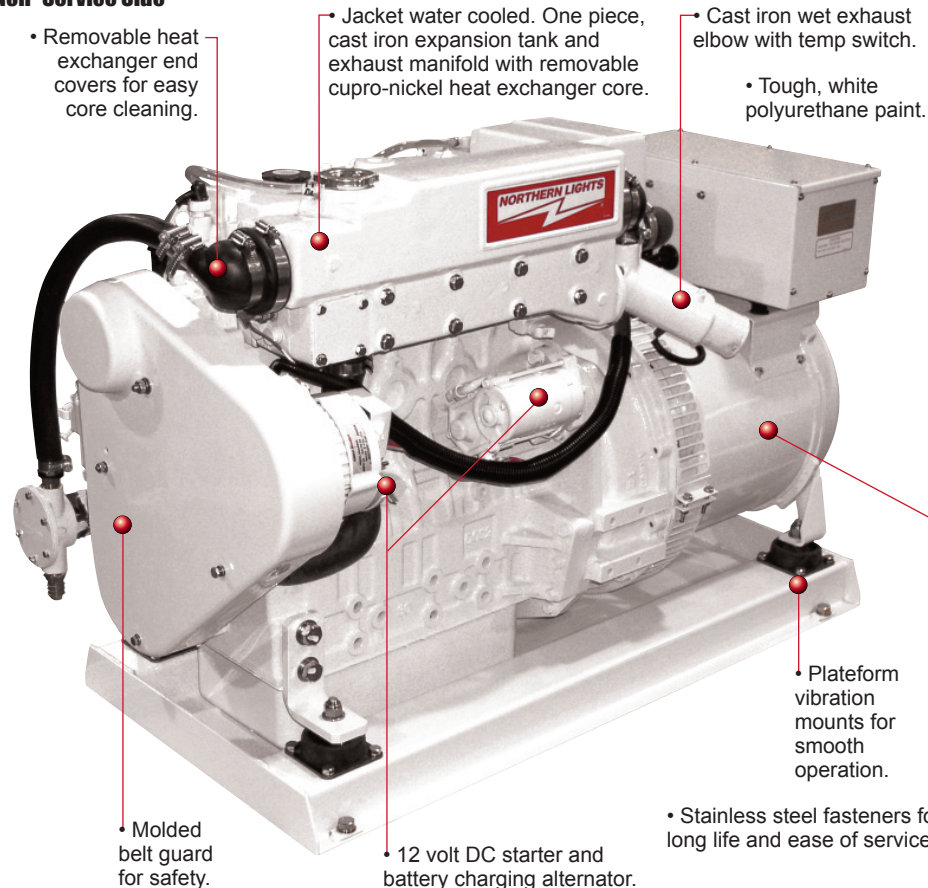

20 kW
60 Hz / 1800 RPM

16 kW
50 Hz / 1500 RPM

These are the powerhouses that go in vessels that need continuous AC power to operate. Unfortunately, some 20 kW machines have small displacement, light duty diesels that can't stand up to heavy use. Some even need turbochargers to compensate for their small displacement.

The M844LW2 is different. Powered by a naturally aspirated, four cylinder, 2.2 liter (135 cid) Luger diesel, this set has the low end torque needed to start bigger electric motors without breaking a sweat.

The M844LW2 meets US EPA Tier II emission standards to protect the environment you enjoy.



Vibration isolation mounts, air intake silencer and cast manifolds make the set remarkably smooth and quiet. A high attenuation sound enclosure is optional.

Northern Lights generator sets are simple to operate and maintain. A 20 foot wire harness and control panel lets you operate it from your boat's bridge. The engine's DC electrical system uses reliable relays instead of delicate printed circuit boards. If a failure should occur, you can simply plug in an inexpensive relay. All service points are on one side within easy reach. The sea water pump is up front for easy impeller changes.

Need hydraulic power? Add an optional electric clutch front PTO. At the touch of a button you have power for your bowthrustrer and winches without starting your main engine.



Featuring new W-Series generator

The new W-Series generator end is a major step in our constant quest to give you the best generator set on the market.

It features an auxiliary stator winding that supplies separate and stable power to the Automatic Voltage Regulator (AVR). The results are impressive:

- Classification society compliance.
 - Real 300% short circuit capability.
 - Improved AC circuit breaker performance.
- See your dealer for more information.



AC Output ¹	
20 kW	60 Hz, 1800 RPM, 1 Ph, 1.0 PF, 120-240 V/83 A, 120 V/166 A
16 kW	50 Hz, 1500 RPM, 1 Ph, 1.0 PF, 220 V/72.7 A

Optional **Three Phase with 0.8 PF**
Voltage regulation **±1%**

Lugger L844L2 Engine	
Type	Vertical inline 4 cylinder diesel
Displacement	135 in ³ (2.2 ltr)
Bore/Stroke	3.30/3.90 in (84/100 mm)
HP @ RPM	32/1800 25.6/1500
Approx. fuel use	
1800 RPM @ full load ²	1.7 gph (6.5 lph)
1800 RPM @ half load ²	1.0 gph (3.9 lph)
1500 RPM @ full load ²	1.36 gph (5.2 lph)
1500 RPM @ half load ²	0.8 gph (3.0 lph)

Installation Data & Weight	
Wet exhaust elbow	2 inch (51 mm) OD
Raw water inlet	3/4 inch (19 mm) OD
Fuel inlet and return	1/4 inch NPT
Approximate dry weight	945 lbs (429 kg)

1. Based on SAE J1995 and ISO 3046.
2. Actual fuel consumption will vary depending on operating conditions.

M844LW2 Dimensional Drawing

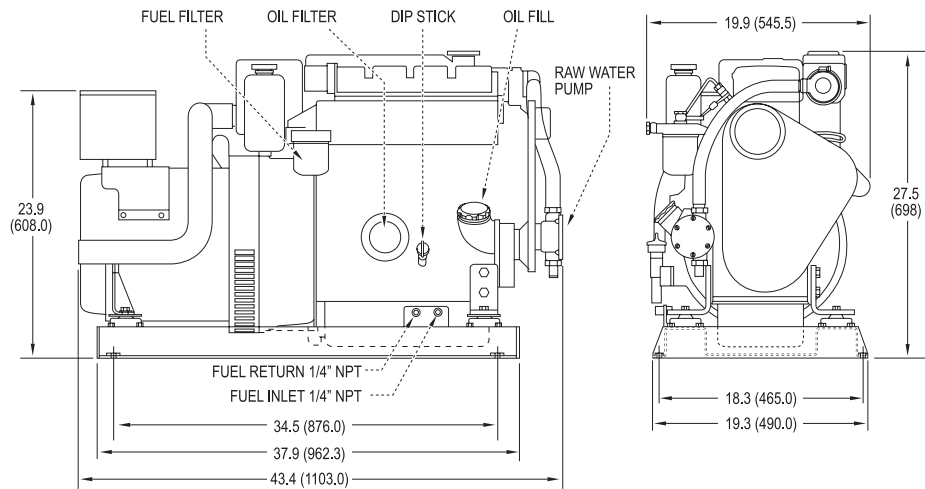

M844LW2 Overall Dimensions L x W x H: 43.4 x 19.9 x 27.5 inch (1103 x 545.5 x 698 mm)
 Dimensions given in inches (mm). Dimensions subject to change without notice.
 Contact dealer or visit www.northern-lights.com for most current installation drawings.

M844LW2 Features and Benefits

Engine Block

- Four cycle, 4 cylinder, liquid cooled, naturally aspirated, overhead valve diesel.
- Swirl combustion chambers improve fuel efficiency and reduce smoke.
- Glow plugs for quick cold starting.

Cooling System

- Freshwater cooling system in heat exchanger or keel cooled configuration.
- One-piece heat exchanger, expansion tank and liquid cooled exhaust manifold. Fewer troublesome hoses and gaskets. Cast iron to resist corrosion and electrolysis.
- Heat exchanger cooling is standard. Tube-type heat exchanger has removable ends for easy cleaning. Easily accessible, rubber impeller, seawater pump of bronze and stainless steel is gear driven; no belts.

Fuel System

- Fuel system is self-venting.
- Injection pump with 5% mechanical governor for close AC frequency control.
- Pintle injectors with replaceable tips.
- Mechanical lift pump with hand primer. No electric pump to fail.
- Large spin-on fuel filter.
- Flexible fuel lines routed to fuel manifold.
- Stop solenoid controls the fuel rack, not throttle, to eliminate speed variance and linkage problems.

Intake and Exhaust

- Meets US EPA Tier II emission requirements.
- Washable air cleaner in cast intake manifold reduces intake noise.
- Cast iron, wet exhaust elbow for safety.

Lubrication System

- Full flow, spin-on oil filter with bypass.
- 8.6 qt. (8.2 ltr) oil capacity for better lubrication. 200 hr oil change intervals.
- Oil drain for quick, clean oil changes.
- Crankcase vapor trap for clean engine room.

DC Electrical System

- DC system uses reliable relays instead of unrepairable printed circuit board.
- 12 volt starter motor and battery charging alternator with regulator and belt guard.
- Standard panel: Remote mount S-1B has hour meter, stop-start switch with run light and preheat switch.
- Expandable to six panels up to 110 feet from the generator set.
- 20 foot (6 m) plug-in panel harness lets you mount your panel anywhere onboard. Better than an inaccessible unit mount panel that is prone to vibration problems.
- Low oil pressure, high coolant and exhaust temperature shutdowns are standard.



AC Generator

- Northern Lights, direct coupled, brushless, AC generator is maintenance free. Four lead, 1 phase 50 or 60 Hz output standard. 12 lead-3 phase optional. Conservative heat rise rating: 95°C/50°C ambient.
- Automatic Voltage Regulator is powered by dedicated AC winding for true 300% short circuit capability. Quick ±1% RMS no load to full load voltage regulation. AVR has circuit breaker protection.

- Generator features high quality Class "H" epoxy insulation, accessible diodes, over-sized bearing and junction box for wiring.

Special Equipment

- Welded steel base frame with drip pan.
- Four platform mounts isolate vibration.
- White, long-life polyurethane paint.
- Operator's and parts manuals standard.

Classification Standards



- Contact factory for details.

Optional Equipment

See separate option brochure for details.

- Front power take off with electric clutch.
- Control panels with DC and AC gauges.
- 24 volt DC isolated or standard ground.
- Wire harness extensions and "Y" harness.
- 2 inch wet exhaust muffler.
- Exhaust / water separator.
- Keel cooling configuration.
- Alarms and shutdowns for low oil level, low coolant level, raw water flow and overspeed.
- Dry exhaust elbow.
- Onboard parts kits.
- Fuel filter-water separators.
- Shorepower switches.
- Sound enclosure has powder coated marine aluminum panels lined with sound barrier foam to dampen noise. Trigger latches for easy service access.



LxWxH: 49.91 x 27.16 x 29.74 in
 (1267.7 x 689.9 x 755.4 mm)
 Weight: 125 lbs (57 kg)

Dealer

4420 14th Ave. NW., Seattle WA 98107
 Tel: (206) 789-3880 • 1-800-762-0165 • Fax: (206) 782-5455
 Information and dimensions subject to change without notice.
 Northern Lights and Lugger are registered trademarks of Alaska Diesel Electric, Inc.
 © 2007 All rights reserved. Litho USA. L674 05/07



www.northern-lights.com