

***For Your Convenience: This Northern
Lights File Is Shared By Diesel Parts Direct***



YOUR ONE STOP SUPERSTORE FOR DIESEL ENGINE PARTS

SHOP NOW

M843NW3 - 12 kW/10 kW
AC Output¹

12 kW 60 Hz, 1800 RPM, 1 Ph, 1.0 PF,
120-240 V/50A, 120 V/100A

10 kW 50 Hz, 1500 RPM, 1 Ph, 1.0 PF,
220 V/45.4A

Optional Three Phase with 0.8 PF
Voltage regulation ±1%

Lugger L843N Engine

Type Vertical inline 3 cylinder diesel

Displacement 91 in³ (1.5 ltr)

Bore/Stroke 3.30/3.50 in (84/90 mm)

HP @ RPM 20.1/1800 16.8/1500

Approximate fuel use

1800 RPM @ full load² 1.20 gph (4.50 lph)

1800 RPM @ half load² 0.62 gph (2.30 lph)

1500 RPM @ full load² 1.00 gph (3.78 lph)

1500 RPM @ half load² 0.51 gph (1.93 lph)

Installation Data & Weight

Wet exhaust elbow 2 inch (51 mm) OD

Raw water inlet 3/4 inch (19 mm) OD

Fuel inlet and return 1/4 inch NPT

Approximate dry weight 837 lbs (380 kg)

1. Based on SAE J1995 and ISO 3046.
2. Actual fuel consumption will vary depending on operating conditions

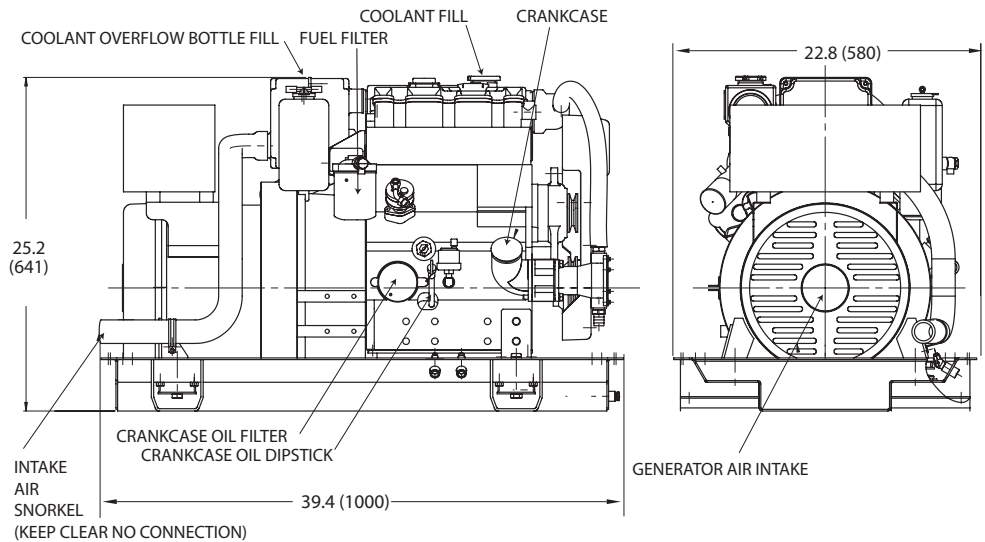
Dimensional Drawing

M843NW3 Overall Dimensions: L x W x H: 39.4 x 22.8 x 25.2 inch (1000 x 580 x 641 mm)

Sound Enclosure Dimensions L x W x H: 39.4 x 22.8 x 25.7 inch (1000 x 580 x 654 mm)

Sound Enclosure Weight: 75 lbs. (34 kg)

Dimensions given in inches (mm). Dimensions subject to change without notice.
Contact dealer or visit www.northern-lights.com for most current installation drawings.

M843NW3 Features and Benefits
Engine Block

- Four cycle, 3 cylinder, liquid cooled, naturally aspirated, overhead valve diesel.
- Swirl combustion chambers improve fuel efficiency and reduce smoke.
- Glow plugs for quick cold starting.

Cooling System

- Freshwater cooling system in heat exchanger or keel cooled configuration.
- One-piece heat exchanger, expansion tank and liquid cooled exhaust manifold. Fewer troublesome hoses and gaskets. Cast iron to resist corrosion and electrolysis.
- Heat exchanger cooling is standard. Cupro-nickel tube-type heat exchanger has removable ends for easy cleaning. Rubber impeller seawater pump of bronze and stainless steel is gear driven; no belt.

Fuel System

- Fuel system is self-venting.
- Injection pump with 5% mechanical governor for close AC frequency control.
- Pintle injectors with replaceable tips.
- Mechanical lift pump with hand primer. No electric pump to fail.
- Large spin-on fuel filter.
- Flexible fuel lines routed to fuel manifold.
- Stop solenoid controls the fuel rack, not the throttle, to eliminate speed variances and linkage problems.

Intake and Exhaust

- Meets US EPA Tier III emission standards at date of manufacture.
- Washable air cleaner in cast intake manifold reduces intake noise.
- Cast iron, wet exhaust elbow for safety.

Lubrication System

- Full flow, spin-on oil filter with bypass.
- 4.2 qt (4 ltr) oil capacity for better lubrication. 200 hour oil change intervals.
- Oil drain for quick, clean oil changes.
- Closed crankcase vent system traps oil vapor and keeps engine room clean.

DC Electrical System

- DC system uses reliable relays instead of an unrepairable printed circuit board.
- 12 volt starter motor and battery charging alternator with regulator and belt guard.
- Standard panel: Remote mount S-1B has hour meter, stop-start switch with run light and preheat switch.
- Expandable to six panels up to 110 feet from the set.
- 20 foot (6m) plug-in panel harness lets you mount your panel anywhere onboard. Better than inaccessible unit mount panels that are prone to vibration problems.
- Low oil pressure, high coolant temp and high exhaust temp safety shutdowns standard.

AC Generator

- Northern Lights, direct coupled, brushless AC generator is maintenance free. 4 lead, 1 phase, 50 or 60 Hz output standard. 12 lead, 3 phase optional. Conservative heat rise rating: 95°C/50°C ambient.
- Automatic voltage regulator (AVR) is powered by dedicated AC winding for true 300% short circuit capability and circuit breaker protection. Quick ±1% RMS no load to full load voltage regulation.
- Generator features high quality, Class "H" epoxy insulation, accessible diodes, over-sized bearings and junction box for wiring.

Special Equipment

- Welded steel base frame with drip pan.
- Four platform mounts isolate vibration.
- White, long-life polyurethane paint.
- Operator's and parts manuals standard.

Classification Standards

- Consult factory for details.



www.northern-lights.com

Dealer

Northern Lights, Inc. • 4420 14th Ave. NW., • Seattle WA 98107
Tel: 206-789-3880 • 1-800-762-0165 • Fax: 206-782-5455
Information and dimensions subject to change without notice.
Northern Lights and Lugger are registered trademarks of Northern Lights, Inc.
© 2012 All rights reserved. Litho USA. S104 2/14