

Electronic Speed Switches

SPS-97118B
Revised 10-03
Catalog Section 20
(00-02-0285)

FWMurphy

HD9063 Series, OS77D Series and SS300 Series

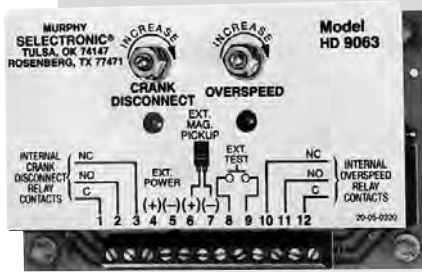

HD9063

SS300

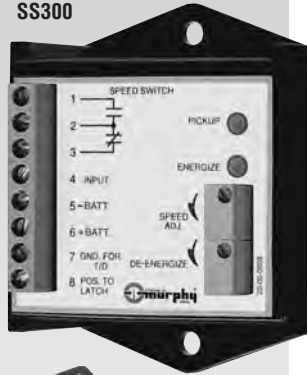

OS77D

- Models for Overspeed, Crank Termination, or Crank Termination and Overspeed
- Solid State Construction
- Compact Design
- Field Adjustable Set Points
- High Noise Immunity

Description

Murphy Electronic Speed Switches are available in various configurations to cover a wide variety of applications. These compact devices receive their input signal from various sources depending upon the particular speed switch model and application. They are available in single or dual switch point models and the switch point(s) are field adjustable. Models are available in self-contained enclosures and as PC-board design for inclusion in your control cabinet. All Murphy speed switches are designed to operate in harsh environments and have high electrical noise immunity.

Series Models Available

SS300 Series: Single set point speed switch with SPDT relay dry contact output.

OS77D Series: Single set point speed sensing module, with a transistor output.

HD9063 Series: Dual set point speed switch in a pc board configuration and relay outputs.

Applications

Murphy speed switches applications include operating alarms, equipment shutdown and modulating control devices. They are ideal for disconnecting starter cranking on auto start systems or overspeed switching:

- Generators
- Compressors
- Industrial Engines
- Pumps
- Vehicles
- Farm Equipment

Select a Speed Switch

In selecting the best Speed Switch for your application, the following factors should be considered:

1. Number of Switch Points.

How many switch points are needed to perform the speed switching function you require?

2. Available Signal Sources.

The signal source must provide a minimum frequency and a minimum, but less than maximum, voltage as required by the selected speed switch.

3. What Is the Frequency Output of the Signal Source?

The following signal sources can be used with most Murphy Electronic Speed Switches. Note they may additionally provide the signal and/or power source for some Murphy Tachometer/TACHSWICH™ instruments.

Magnetic Sensor: The sensor is usually mounted through the flywheel housing so that the sensor tip is in close proximity to the ring gear teeth. Output voltage is dependent upon the amount of the gap between the sensor tip and the gear tooth.

$$\text{Set Point Frequency in Hz} = \frac{\text{No. Gear Teeth} \times \text{RPM Set Point}}{60}$$

Alternator Output: Most industrial engine alternators have an "auxiliary" or "tachometer" tap. This tap can provide the signal source for speed switches and tachometers.

$$\text{Set Point Frequency in Hz} = \frac{\text{Pulley Ratio} \times \text{No. of Alternator Poles} \times \text{RPM Set Point}}{120}$$

Ignition Output: This battery ignition signal is commonly used on gasoline and natural gas fueled type engines. The tap is usually located either on the distributor or on the ignition coil. The ignition can be breaker point type or all electronic.

For 2-cycle

$$\text{Set Point Frequency in Hz} = \frac{\text{No. of Cylinders} \times \text{RPM Set Point}}{60}$$

For 4-cycle

$$\text{Set Point Frequency in Hz} = \frac{\text{RPM} \times \text{No. of Cylinders}}{2 \times 60}$$

Signal Generators: Add-on signal generators produce a voltage and frequency output. Match this output to the requirements of the speed switch selected.



SS300 Series

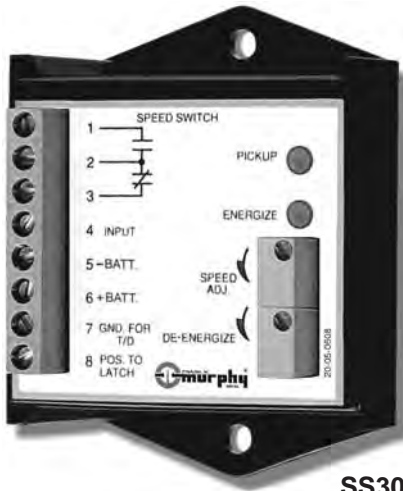

SS300

Description

The SS300 Series are single set point speed switches with SPDT relay dry contact output. The trip point is set by a potentiometer. An LED indicates when the signal source is present. A second LED turns on when the trip point is reached. See Table 1 for available models and requirements. An optional time delay is on board to delay operation of the relay for 2-6 seconds after the set point has been reached.

The SS300 Series speed switch is intended for installation within a weather-proof enclosure to protect it from rain, dust, etc.

Application

Overspeed shutdown. Shuts down the engine if RPM exceeds the pre-set limit.

Speed sensitive pull-in/drop-out. Engage or disengage PTO's, 4-wheel drives, other switch points, etc. according to speed of engine being monitored.

Engine and transmission alarms/shutdowns. Oil pressure in some engines and transmissions varies widely between running and idle speeds. The SS300 Series can select between two pressure switch set points according to speed of the engine or transmission and thus give maximum protection to the equipment while at operating RPM and eliminate nuisance alarms when at idle.

Adjustable differential model. The ("AD") can be adjusted to change the speed range over which the pull-in and drop-out differential of the relay will operate. A typical application is to insure that engine speed is above a minimum RPM before applying a load but allows a drop in speed of several hundred RPM without disconnecting the load.

Table 1: Models Available and Input Signal

Model Number	Distributor Ignition	Magnetic Pickup	Alternator	Voltage	
				12	24
SS300 (std. model)		X		X	X
SS300-LF (low frequency)	X		X	X	X
SS300-AD (adjustable differential)		X		X	X
SS300-AD-LF (low frq. & Adjst. diff.)	X		X	X	X

Specifications

Power Requirements:

12 VDC (9-16 VDC).

24 VDC (18-30 VDC).

Frequency Signal:

Voltage (all models):

- Minimum Input Voltage Signal: 4.5 Vrms.
- Maximum Input Voltage Signal: 50 Vrms.

Maximum Current	12V	24V
Pull In	46 mA	46 mA
Pickup only	10.5 mA	16 mA

Frequency Range in Hz	Model Number
25-2000	SS300-LF SS300-AD-LF
625-9000	SS300-AD SS300

Reset Differential Magnetic Pickup Signal Models:

- "Standard Models: 2 Hz Differential.
- "AD" Models (Adjustable Differential): 650-8900 Hz Adjustable

Reset Differential Alternator Models:

- "LF" Models (Low Frequency): 2 Hz Differential
- "AD-LF" Models (Adjustable Differential Low Frequency): 50-1900 Hz Adjustable.

Output: Relay contact, SPDT, resistive load, 6 A, 30 VDC.

Time Delay: When terminal 7 is grounded, the relay operation is delayed for 2-6 seconds after rpm set point is reached.

Adjustment: 20-turn potentiometer(s).

Temperature Range: -4° to 185°F (-20° to 85°C).

Relative Humidity: 0 to 95% Non-condensing.

Case: Black, ABS plastic.

How to Order

To order, specify the model number and voltage (see Table 1, at left).

Example: SS300-LF-12

Shipping Weight (all models): 0.24 lb. (108 g).

Shipping Dimensions (all models): 8 x 4 x 4-1/2 in. (203 x 102 x 114 mm).

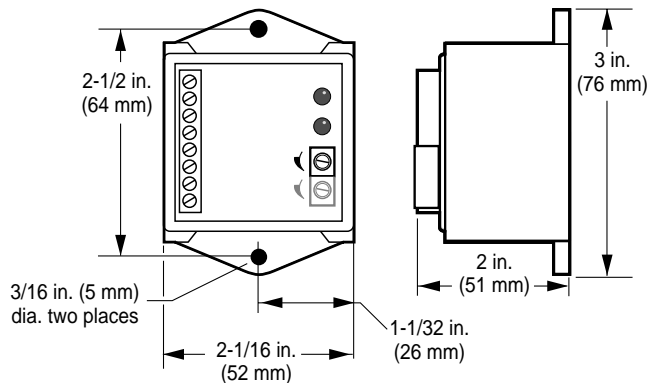

Description

The HD9063 Series is a unitized two set point speed switch with SPDT relay outputs. HD9063 is a PC-board configuration with standoffs for mounting in a control panel or cabinet.

The HD9063 provides crank disconnect and overspeed functions. Trip points can be field adjusted on all models. LED's next to the set point potentiometers indicate that the trip point has been reached and the relay(s) have operated. An overspeed test circuit is built-in; it will actuate the output relay at a point 10% below actual overspeed set point.

Application

Crank disconnect/overspeed model is typically used to disconnect the starter on automatic start engine applications and to shutdown the engine if an overspeed situation occurs. Re-engagement of the starter is inhibited until RPM returns virtually to zero. Typical applications include: standby generator sets; pumps and compressors.

Specifications

Power Supply: Voltage: 8-30 VDC.

Maximum Current: 150 mA.

Frequency Signal: (Voltage, Magnetic Pickup Signal Models):

- Minimum: 0.35 Vrms.
- Maximum: 60 Vrms.

Maximum Current, Magnetic Pickup Signal Models: 4.8 μ A.

Adjustment Range, Magnetic Pickup Signal Models:

- HD9063 Model
Crank Disconnect: 250-6,000 Hz.
Overspeed: 1,100-10,000 Hz.

Reset Differential, Magnetic Pickup Signal Models

- HD9063 Model
Crank Disconnect: Dropout 160 Hz \pm 5%.
Overspeed: 200 Hz Differential.

Output: Relay Contact, SPDT, Resistive Load: (2) 5 A 30 VDC.

Adjustment: (2) 270°-turn potentiometer.

Temperature Range: 14 to 158°F (-10 to 70°C).

How to Order

Specify model numbers below:

HD9063: Two set points; PC board mounting; crank disconnect and overspeed.

Shipping Weight (all models): 2 lbs. (0.90 Kg).

Shipping Dimensions (all models): 10 x 9 x 6 in. (254 x 229 x 152 mm).

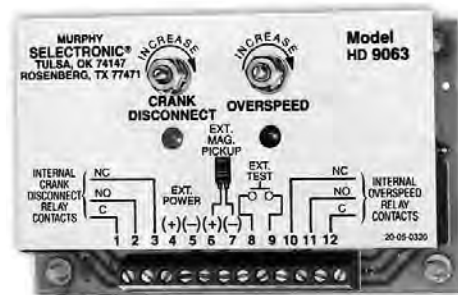

HD9063

Dimensions

HD9063

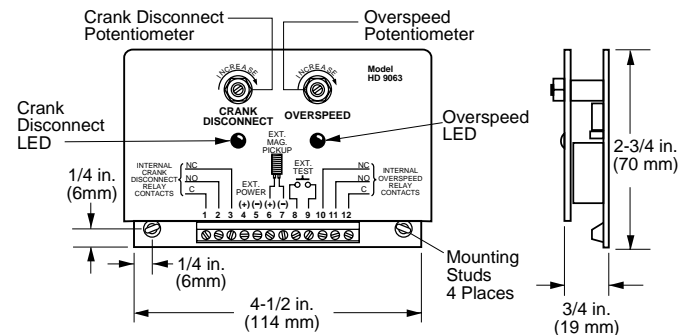

OS77D Series



OS77D

Description

The OS77D Series single set point speed switch is a compact all-electronic speed sensing module. It can be panel mounted via its trip set point potentiometer. It is field adjustable and gives a transistor output when tripped. Relay models available.

Models are available with Normally Open or Normally Closed circuit and with or without re-crank feature which inhibits starter re-engagement until the engine speed is near zero RPM.

Application

Overspeed shutdown. Activates engine shutdown circuit on engine overspeed.
Operate PTO's or drive circuits. Engage or disengage engine PTO, 4-wheel drives, or other control circuits according to RPM monitored.
Disconnect engine cranking when engine starts.

Specifications

Power Supply: Voltage: 7-28 VDC.

Maximum Current: 100 mA.

Frequency Signal:

Voltage, Magnetic Pickup Signal Models

- Minimum: 1.2 Vrms
- Maximum: 30 Vrms

Voltage, Distributor Ignition Models

- Minimum: 6 Vrms
- Maximum: 30 Vrms

Maximum Current, Magnetic Pickup Signal Models: 0.12 mA

Maximum Current, Distributor Ignition Models: 0.12 mA
Adjustment Range, Magnetic Pickup Signal Models: 1000-10,000 Hz
Adjustment Range, Distributor Ignition Models: 40-400 Hz
Reset Differential, Magnetic Pickup Signal Models

- Non-recrank model: 10 Hz Differential
- Recrank model: dropout 54 Hz

Reset Differential, Distributor Ignition Models

- Non-recrank model: 10 Hz Differential
- Recrank model: Dropout 2.4 Hz

Output: Transistor Sink to Ground Resistive Load: 2 A, 28 VDC

Adjustment: 270°-turn potentiometer

Temperature Range: -13° to 185°F (-25° to 85°C)

How to Order

Specify model numbers below:

OS77D-900NTO: Normally Open; 1000—10,000 Hz, magnetic sensor input.

OS77I-040NTO: Normally Open; 40—400 Hz, distributor ignition input.

OS77D-900NTC: Normally Closed; 1000—10,000 Hz, magnetic sensor input.

OS77D-900RTC: Normally Closed; 1000—10,000 Hz, max. with recrank feature.

NOTE: See "Specifications" for individual model specifications.

Shipping Weight (all models): 1 lb. (0.45 Kg)

Shipping Dimensions (all models): 8 x 4 x 4-1/2 in. (203 x 102 x 114 mm)

Dimensions

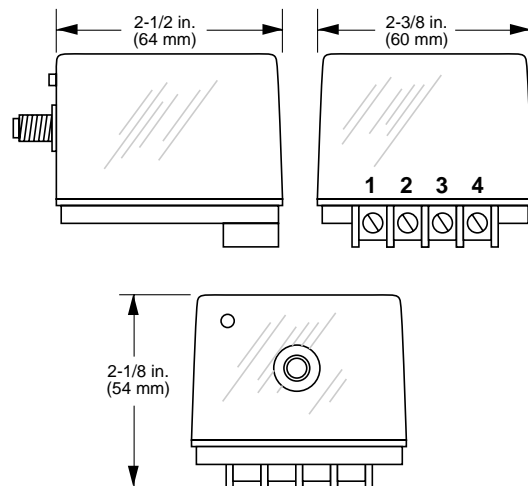

Warranty

A limited warranty on materials and workmanship is given with this FW Murphy product.
A copy of the warranty may be viewed or printed by going to www.fwmurphy.com/support/warranty.htm



FW Murphy
P.O. Box 470248
Tulsa, Oklahoma 74147 USA
+1 918 317 4100
fax +1 918 317 4266
e-mail sales@fwmurphy.com
www.fwmurphy.com

CONTROL SYSTEMS & SERVICES DIVISION
P.O. Box 1819; Rosenberg, Texas 77471; USA
+1 281 633 4500 fax +1 281 633 4588
e-mail sales@fwmurphy.com

MURPHY DE MEXICO, S.A. DE C.V.
Blvd. Antonio Rocha Cordero 300, Fracción del Aguaje
San Luis Potosí, S.L.P.; México 78384
+52 444 8206264 fax +52 444 8206336
Villahermosa Office +52 993 3162117
e-mail ventas@murphymex.com.mx
www.murphymex.com.mx

FRANK W. MURPHY, LTD.
Church Rd.; Laverstock, Salisbury SP1 1QZ; U.K.
+44 1722 410055 fax +44 1722 410088
e-mail sales@fwmurphy.co.uk
www.fwmurphy.co.uk

MURPHY SWITCH OF CALIFORNIA
41343 12th Street West
Palmdale, California 93551-1442; USA
+1 661 272 4700 fax +1 661 947 7570
e-mail sales@murphyswitch.com
www.murphyswitch.com

MACQUARRIE CORPORATION
1620 Hume Highway
Campbellfield, Vic 3061; Australia
+61 3 9358 5555 fax +61 3 9358 5558
e-mail murphy@macquarrie.com.au



In order to consistently bring you the highest quality, full featured products, we reserve the right to change our specifications and designs at any time.

Printed in U.S.A.