



Lube Level Maintainer

Models LM500/LM500-TF

Installation Instructions

Warranty - A limited warranty on materials and workmanship is given with this Murphy product. A copy of the warranty may be viewed or printed by going to <http://www.fwmurphy.com/warranty>.



BEFORE INSTALLING THIS MURPHY PRODUCT:

- A visual inspection of this product for damage during shipping is recommended before installation.
- It is your responsibility to ensure that qualified mechanical and electrical technicians install this product.
- Disconnect all electrical power to the machine.
- Make sure machine cannot operate during installation.
- Follow all safety warnings of the machine manufacturer.
- Read and follow all installation instructions.
- Please contact Enovation Controls immediately if you have any questions.

Table of Contents

General Information	1
Description	1
Dimensions	1
Operating the Range of the Snap Switch	2
Test Feature.....	2
Thumb-Valve™ Operation.....	3
LM500 Series Flow Rates	3
Service Parts (Specify part number)	3
Hose Kit: (P/N 15000355)	4
Vent Fittings Kit: (P/N 15000954).....	4
Fittings Kit: (P/N 15000943)	4
Typical Installation	5
Mounting the LM500	5
Pipe Bracket Mounting (PM) (P/N 15000518)	5
Universal Bracket Mounting (UB) (P/N 15000519).....	5
Base Mounting.....	5
Crankcase (Oil Pan) Mounting.....	6
Connecting Fittings and Hoses	7
Connecting the LM500 to an Oil Supply Tank.....	8
LM500 Typical Installation Shown.....	8
Specifications	9

THIS PAGE INTENTIONALLY LEFT BLANK

General Information

Description

The Murphy LM500 model maintains the crankcase oil level of an engine, pump or compressor. Adjusted to the correct running-oil-level, the LM500 will replenish oil as it is used. The low-level switch will alarm and/or shutdown the equipment if the supply oil is lost and the equipment continues to use oil. The LM500-TF model includes a test feature that confirms both the float and switch are operating correctly with a single press of the test button.

Dimensions

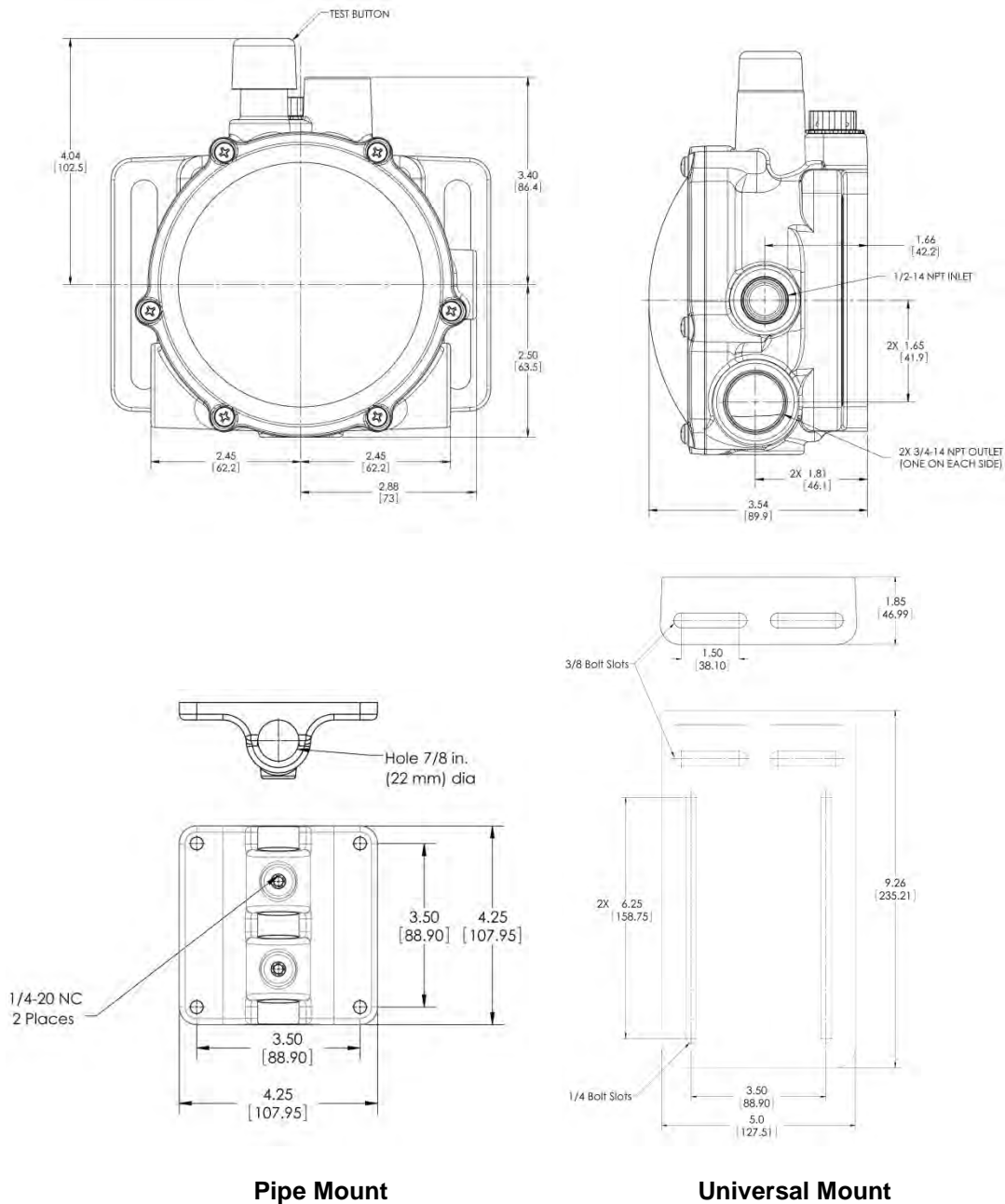

Pipe Mount

Universal Mount

Operating the Range of the Snap Switch

Figure 1 shows the LM500 dial and the operating range of the switch. If level is within the designated zones, the switch will activate.

The switch activates approximately 1/4 in. (6 mm) from the bottom of the low zone. The dial-in **Figure 1** shows that if the level continues to drop into the low-low zone, a shutdown will occur.

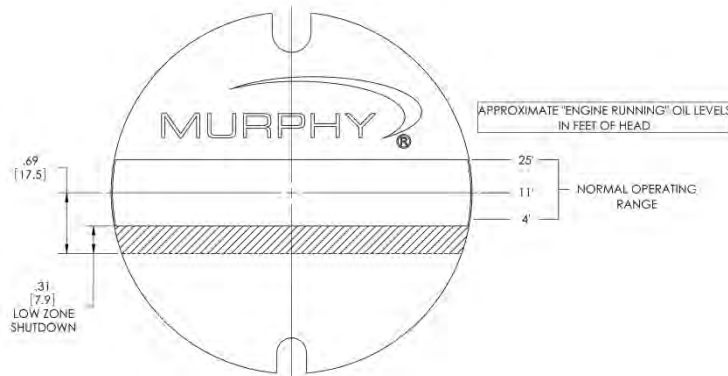

Figure 1

NOTE: color zones on dial face show approximate normal operating zones. Actual conditions may vary depending upon operating characteristics of the engine. Placement of the LM500 according to the above instructions will compensate for these conditions.

Test Feature

The form C (3-wire) contact allows a controller/enunciator to be wired as a closed loop system, resulting in a reliable fault-sensitive circuit.

NOTE: Holding test button in for a prolonged period of time could cause crank case to over fill.

Thumb-Valve™ Operation

As the equipment uses oil, the float falls, providing immediate level compensation. At FULL position, the float holds the valve closed. If the clean oil supply is depleted and oil level contuse to fall, the low level switch will operate an alarm or equipment shutdown.

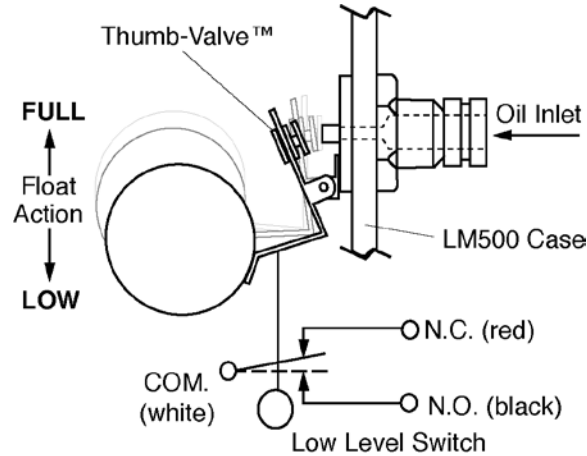

LM500 Series Flow Rates

LM500 Series Flow Rates are based on SAE 40 motor oil @2 ft. head pressure. Friction losses due to piping are not considered.

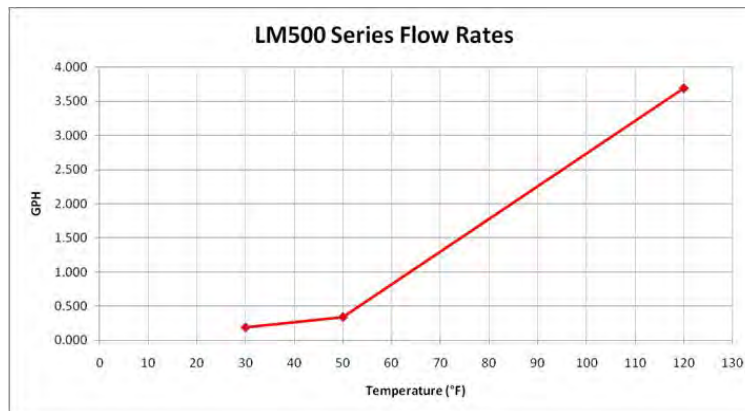

Service Parts (Specify part number)

Description	Part Number
Vent Fittings Kit	15000954
Hose Kit	15000355
1/2 NPT x1/2in Hose Barbed Fitting	89080801
3/4NPT x 1/2in Hose Barbed Fitting	89081001
Pipe Bracket Kit	15000518
Universal Flange Kit	15000519

Hose Kit: (P/N 15000355)

Quantity	Description
1	1/2in (13mm) I.D. x 3ft. (914mm) long hose.
1	1in (25mm) I.D.x 3ft (914mm) long hose.
2	1/2in (13mm) worm gear clamp
2	1in. (25mm) worm gear clamp
2	1/2NPT x 1/2in. (13mm) barbed fitting

Vent Fittings Kit: (P/N 15000954)

Quantity	Description
1	Tubing vent
1	1/4 x 1/4NPT connector

Fittings Kit: (P/N 15000943)

Quantity	Description
1	Tubing vent
1	Hose barb, 1/2NPT to 1/2 Hose.
1	Hose Barb, 1in. I.D. HOSEX 3/4NPT
1	Connector, 1/4T x 1/2

Bubble Lens Kit: (P/N 15000532)

Quantity	Description
1	Dial
1	O-ring, 0.139 C/S, 4.359 ID
6	Shoulder screw, #8-32 x 0.3125
1	Bubble Lens

Typical Installation

Mounting the LM500

NOTE: Mount the LM500 as close as possible to the crankcase.



CAUTION: Excessive vibration can cause overfill. Be sure mounting brackets are supported.

The following instructions are based on the use of the pipe and universal mounting brackets shown on page 1.

Pipe Bracket Mounting (PM) (P/N 15000518)

1. Mount a nominal 1/2in. (13mm) diameter pipe to the base of the engine.
2. Install the pipe bracket to the IM500 using two 1/4-20 UNC x 1 inch bolts; nuts and lock washers supplied. See Figure 2A.
3. Slip the LM500 onto the pipe and install the two adjustment bolts. Each bolt consists of a 1/4-20 UNC x 1 in. bolt, nuts and lock washers. See Figure 2B. **DO NOT** tighten the adjustment screws too tight as height adjustment might be needed later during the operation. Refer to “Connecting Fittings and Hoses”, for more information regarding height adjustment of the LM500 in alignment with the oil level in the crankcase.

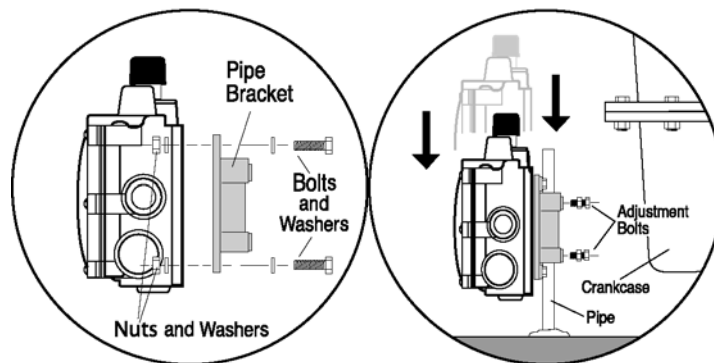

Figure 2A

Figure 2B

Universal Bracket Mounting (UB) (P/N 15000519)

The universal bracket has two mounting methods: base mounting or pan mounting.

Base Mounting

1. Install the universal bracket to the base as shown in Figure 3A using two split lock washers and two 5/16 inch dia. bolts or others as necessary.

2. Mount the LM500 to the universal bracket using four 1/4-20 UNC x 1-1/4 inch (32mm) bolts; flat and lock washers supplied (Figure 3B). DO NOT tighten the adjustment screws too tight as you will have to adjust the LM500 later in the installation process. Refer to “Connecting Fittings and Hoses” for information regarding height adjustment of the LM500 in alignment with the oil level in the crankcase.

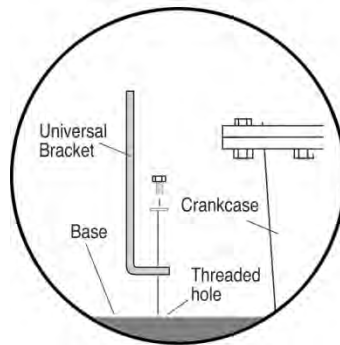

Figure 3A

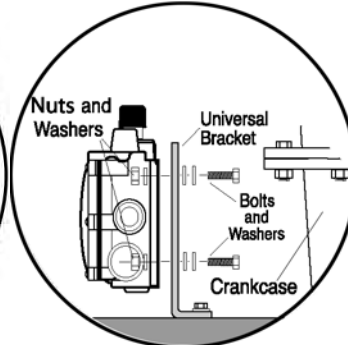

Figure 3B

Crankcase (Oil Pan) Mounting

1. Install the universal bracket to the crankcase using the existing crankcase bolts (Figure 4A). Crankcase bolt diameter must be no larger than 7/16 inch (11mm).

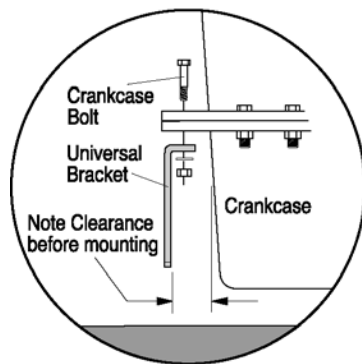

Figure 4A

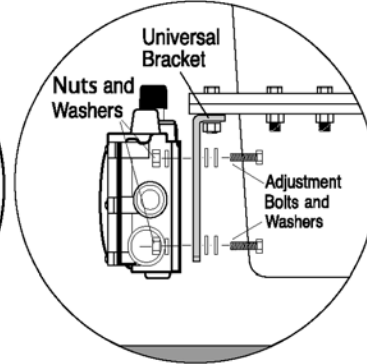

Figure 4B

NOTE: Check clearance between crankcase and mounting bracket before installing the mounting bracket. If space between the crankcase and mounting bracket is narrow, attach LM500 to mounting bracket prior to installation on crankcase.

2. Mount the LM500 to the universal bracket using four 1/4-20 UNC x 1-1/4 inch bolts, flat and lock washers supplied. DO NOT tighten the adjustment bolts to tight as height adjustment might be needed later during the operation. Refer to “Connecting Fittings and Hoses” for information regarding height adjustment of the LM500 in alignment with the oil level in the crankcase.

Connecting Fittings and Hoses

The following instructions are based on the Murphy hose kit described on page 3.

1. Install the LM500 fittings in their proper locations.

NOTE: Apply a sealant such as Teflon®, to all threaded connections.

2. Attach the 1 inch (25mm) diameter, flexible monitoring hose to the crankcase and the monitoring port on the LM500. See Figure 5.

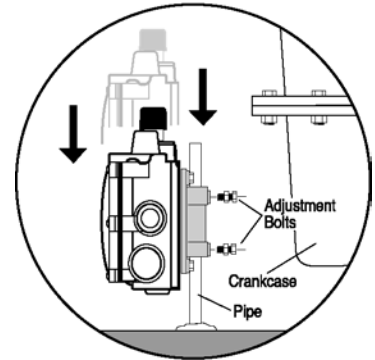

CAUTION: The hose must slope slightly downward from the LM500 and **MUST NOT** have any droops or low spots.

NOTE: If the drain plug on the crankcase is used for the connection, it is recommended that a tee be installed to allow draining of the crankcase for service.

3. Install the 1/2 inch (13mm) I.D. x 3 ft (914 mm) hose to the vent connection on the LM500 and to vent connection on the crankcase. See Figure 5. **The vent connection on the crankcase must be well above the regulated oil level.** All hoses must be clear of obstructions, valleys, or dips that could create liquid traps, or gas/air pockets. The vent and crankcase connections should be as straight as possible.
BEFORE CONTINUING, VERIFY THAT ALL HOSE CLAMPS ARE TIGHT.

4. Fill the crankcase to the proper oil level.



IMPORTANT: With the engine running and warm, loosen the mounting bracket adjustment bolts and adjust the LM500 so that the oil level in the sight gauge is aligned with the middle of the green bar on the dial (see example, Figure 5).

5. Tighten the adjustment bolts securely.

Connecting the LM500 to an Oil Supply Tank

1. Remove the plug from the oil inlet connection. Be sure the removable screen, inside the connection, is clear of debris. Install the oil inlet connection.
2. Connect a 1/2inch I.D. (13mm) or larger hose to the oil inlet fitting on the LM500 and to the shutoff valve on the oil supply tank. See Figure 6. Recommended minimum height above the LM500 is 2 ft. (0.6); maximum 25ft (7.7m). The hose must maintain a downward slope and not have low spots or droops. Maximum head pressure rating is 9.50psi or 25ft. oil (head pressure).
3. Before filling the supply tank with oil, be sure the tank is clean and dry and the shutoff valve is closed. Also, be sure all hoses and clamps are tight. Fill the tank with CLEAN oil.



WARNING: Overfill condition can be caused by excessive inlet pressure and/or improper "vent-to-crankcase" installation.

4. After oil supply tank is full, open the shutoff valve.

Next, make the proper electrical connections for the application. (See snap switch ratings on page 8 and schematic on page 2.)

LM500 Typical Installation Shown



WARNING: Perform this installation using appropriate protection. Trapped air and hot oil may cause burns.

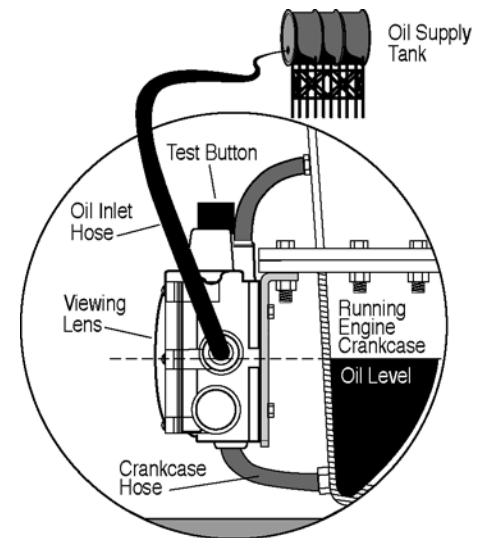
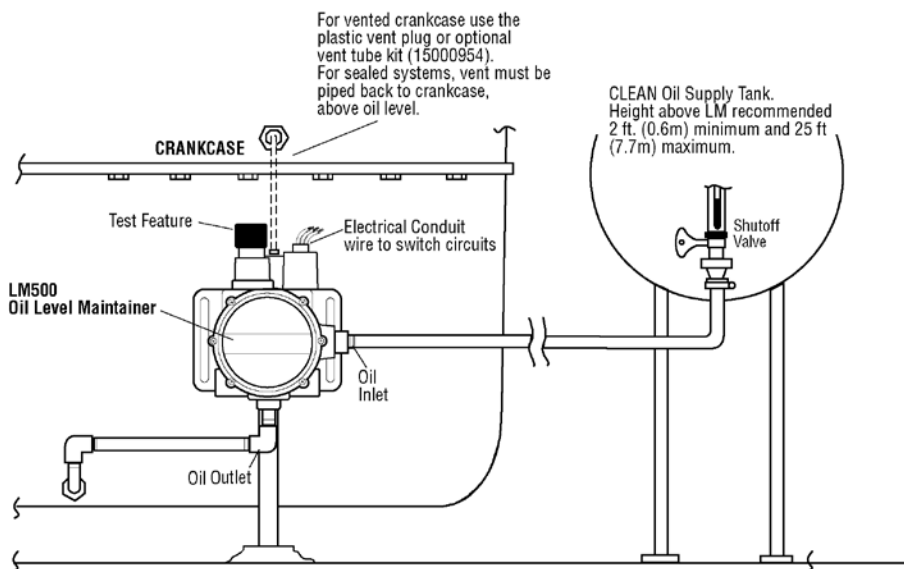

Specifications

Crankcase Balance Vent Connection: 1/2 NPTF (top).

Inlet Connection: 2 x 3/4 NPTF (side)
1 x 3/4 NPTF (bottom)

Thumb-Valve™ Material: Viton

Snap-switch: SPDT rating 10 A, 125 VAC; 0.5 A, 125 VDC; 10 A, 30 VDC

Wire leads: 18 AWGT x 14 in +/- 2 in (355 mm) length.

Conduit Connection: 1/2 inch conduit (female, top). (Refer to 00-02-0735 Teflon Tape Wrapping Technique).

Case: Die cast aluminum

Lens: Clear "Frog Eye" non-staining, high impact, high temperature nylon; UV and heat stabilized.

Dial: High visibility white background with solid green band for normal level indication.

Maximum Inlet Pressure: 9.50 psi/25 ft. oil (head pressure).

Maximum Differential: 2 in (51mm) between running and stopped.

Maximum Ambient Temperature: 250°F (121°C)

Float: 304 Stainless Steel

Flow Rates: Refer to Flow Rate Chart on page 3.

THIS PAGE INTENTIONALLY LEFT BLANK

THIS PAGE INTENTIONALLY LEFT BLANK

In order to consistently bring you the highest quality, full-featured products, we reserve the right to change our specifications and designs at any time. MURPHY products and the Murphy logo are registered and/or common law trademarks of Enovation Controls, LLC. This document, including textual matter and illustrations, is copyright protected by Enovation Controls, LLC, with all rights reserved. (c) 2013 Enovation Controls, LLC. A copy of the warranty may be viewed or printed by going to <http://fwmurphy.com/warranty>.

ENOVATION CONTROLS CORPORATE HEADQUARTERS

5311 S 122ND EAST AVENUE
TULSA, OK 74146

ENOVATION CONTROLS – SAN ANTONIO OFFICE

5757 FARINON DRIVE
SAN ANTONIO, TX 78249

ENOVATION CONTROLS – HOUSTON OFFICE

105 RANDON DYER RD
ROSENBERG, TX 77471

FW MURPHY, LTD. – UNITED KINGDOM

CHURCH ROAD LAVERSTOCK
SALISBURY SP1 1QZ UK

MURPHY ECONTROLS TECHNOLOGIES (HANGZHOU) CO, LTD.

77 23RD STREET
HANGZHOU ECONOMIC & TECHNOLOGICAL DEVELOPMENT AREA
HANGZHOU, ZHEJIANG 310018 CHINA

DOMESTIC SALES & SUPPORT

ECONTROLS PRODUCTS

PHONE: 210 495 9772
FAX: 210 495 9791
EMAIL: INFO@ECONTROLS.COM
WWW.ECONTROLS.COM

MURPHY PRODUCTS

PHONE: 918 317 4100
FAX: 918 317 4266
EMAIL: SALES@FWMURPHY.COM
WWW.FWMURPHY.COM

MURPHY CONTROL SYSTEMS & SERVICES

PHONE: 281 633 4500
FAX: 281 633 4588
EMAIL: CSS-SOLUTIONS@FWMURPHY.COM

MURPHY INDUSTRIAL PANEL DIVISION

PHONE: 918 317 4100
FAX: 918 317 4124
EMAIL: IPDSALES@FWMURPHY.COM

INTERNATIONAL SALES & SUPPORT

UNITED KINGDOM

PHONE: +44 1722 410055
FAX: +44 1722 410088
EMAIL: SALES@FWMURPHY.CO.UK
WWW.FWMURPHY.CO.UK

CHINA

PHONE: +86 571 8788 6060
FAX: +86 571 8684 8878
EMAIL: APSALES@FWMURPHY.COM

LATIN AMERICA & CARIBBEAN

PHONE: 918 317 2500
EMAIL: LASALES@FWMURPHY.COM

SOUTH KOREA

PHONE: +82 70 7951 4100
EMAIL: SKOREASALES@FWMURPHY.COM

INDIA

PHONE: +91 91581 37633
EMAIL: INDIASALES@FWMURPHY.COM

**ISO 9001
REGISTERED**



USA (TULSA) - ISO 9001:2008 FM 28221
USA (ROSENBERG) - ISO 9001:2008 FM 28222
UK - ISO 9001:2008 FM 29422
CHINA - ISO 9001:2008 FM 52385
Registered Facilities

Printed in the USA