

Installation Instructions for Level Maintainers

Model Series LM300

LM-92164N
Revised 10-03
Section 15
(00-02-0176)



Read the following instructions before installing. A visual inspection of this product for damage during shipping is recommended before mounting. These installation instructions are intended for all LM300 series models.

GENERAL INFORMATION

WARNING

BEFORE BEGINNING INSTALLATION OF THIS MURPHY PRODUCT

- ✓ Disconnect all electrical power to the machine.
- ✓ Make sure the machine cannot operate during installation.
- ✓ Follow all safety warnings of the machine manufacturer.
- ✓ Read and follow all installation instructions.

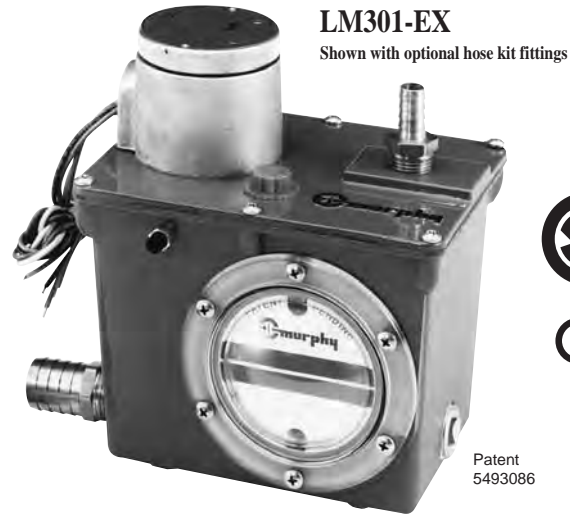

LM300: Level Maintainer only (no switches).

LM301: Low switch contacts for low level shutdown or alarm. Four wires, SPDT.

LM302: Two switches for low and high level shutdown or alarm. Four wires, DPST, wired N.O. in normal operating ranges.

LM303: Two switches for low and high level shutdown or alarm. Four wires, DPST, wired N.C. in normal operating ranges.

LM304: Two switches. Alarm before shutdown on low level and shutdown on low-low level. Four wires, DPST, wired N.O. in normal operating ranges.

LM305: Two switches. Alarm before shutdown on low level and shutdown on low-low level. Four wires, DPST, wired N.C. in normal operating ranges.

Specifications

Case/Cover: Die cast aluminum.

Switch Housing: Aluminum.

Approval Rating: LM301 thru LM305 : CSA certified^{††} for non hazardous locations. Enclosure Type 4 certified.

LM301-EX thru LM305-EX: CSA certified^{††} for Class I, Groups C and D; Class II, Groups F and G hazardous locations. Enclosure Type 4 certified.

Float: Rigid polyurethane foam. Polyurethane coated.

Maximum Ambient Temperature: 250°F (121°C)

Oil Inlet Connection: Top entry 1/2-14 NPT with built-in filter screen (removable for cleaning).

Inlet Orifices: 1/4 in. (6 mm) standard. 1/8 in. (3 mm) available.

Wire (switch models): 18 AWG x 13 in. (1.0 mm² x 330 mm).

Maximum Inlet Pressure (MIP):

Max. Differential: 2 in. (51 mm) between running and stationary oil level. 30 psi (207 kPa) [2.07 bar].
with 1/8 in. (3 mm) orifice.
15 ft. oil (4.6 m oil)
with 1/4 in. (6 mm) orifice.

Maximum Case Pressure (MCP): 15 psi (103 kPa) [1.03 bar].

Orifice Seal[†]: Buna-N Thumb-ValveTM

Switch Contact: Silver, SPDT snap acting, 10A @ 125, 250VAC; 10A @ 30VDC.
(1 only for low level; 2 only for high & low; or 2 only for low with alarm before shutdown)

Outlet Connection: 3/4-14 NPT left side, right side, and bottom.

Crankcase Balance Vent Fitting: 1/2-14 NPT.

Mounting: Accepts Murphy pipe mounting or universal mounting brackets.

Lens: Clear "Frog Eye" non-staining, high impact, high temperature nylon; UV and heat stabilized.

Dial: High visibility white background with green and white "index" lines for normal level indication.

Test Knob: Rotate to test switch operation. Turn clockwise for low level test and turn counterclockwise for high level test.

Flow Rate Test: Using SAE 30 @ 32°F (0°C).

Orifice Diameter	Pressure	Flow Rates
1/4 in.* (6 mm)	4 ft. oil - 15 ft. oil (1.2 m oil - 4.6 m oil)	4.7 GPH - 31.0 GPH (17.8 LPH - 117.3 LPH)
1/8 in. (3 mm)	10 psig - 30 psig (68.9 kPa - 207 kPa) [.69 - 2.07 bar]	16.9 GPH - 32.1 GPH (63.7 LPH - 121.5 LPH)

*Standard

NOTE: Friction losses due to piping NOT considered.

Optional Hose Kit: 1500355

Quantity	Description
1	1/2 in. (13 mm) I.D. x 3 ft. (914 mm) long hose
1	1 in. (25 mm) I.D. x 3 ft. (914 mm) long hose
2	1/2 in. (13 mm) worm gear clamp
2	1 in. (25 mm) worm gear clamp
2	1/2 NPT x 1/2 in. (13 mm) barbed fitting
2	3/4 NPT x 1 in. (25 mm) barbed fitting

††CSA certified with switch contacts rated at 10 A @ 250 VAC (standard).

** Products covered by this bulletin comply with EMC Council directive 89/336/EEC regarding electromagnetic compatibility except as noted.

DIMENSIONS

LM300 Series Enclosures

The dimensions below are for the optional -EX model enclosure. The standard model enclosure dimensions are the same except the height and width which are: 7 in. (178 mm) H, 7-7/8 in. (200 mm) W.

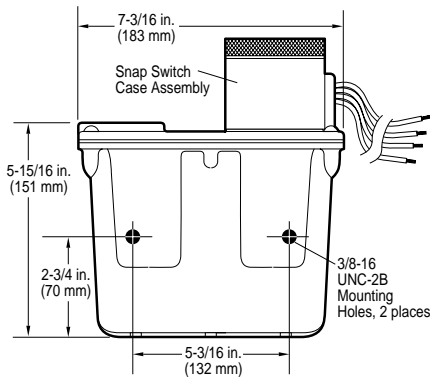
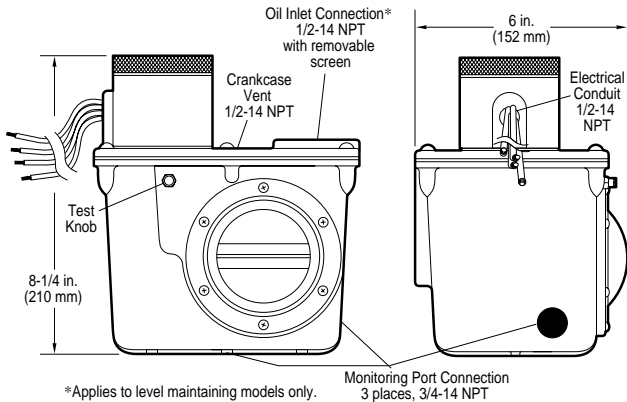

Mounting Brackets with Hardware

15000371 pipe bracket

Additional Hardware Supplied

- (4) 3/8-16 UNC x 1 inch (25 mm) screws
- (4) 3/8-16 nut
- (4) 3/8 I.D. lock washer
- (2) 3/8 I.D. flat washer

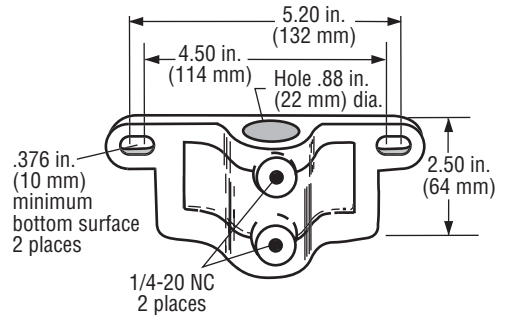

15000370 universal bracket

Additional Hardware Supplied

- (2) 3/8-16 UNC x 1 inch (25 mm) screws
- (4) 3/8 I.D. flat washer
- (2) 3/8 I.D. lock washer
- (2) 3/8-16 nut

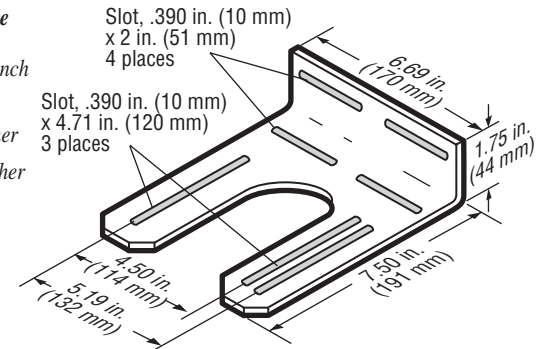

TYPICAL INSTALLATION

Mounting (all LM300 Series models)

NOTE: Mount the LM300 series level maintainers as close as possible to the crankcase. Also, excessive vibration can cause overflow. Be sure mounting brackets are supported.

The following instructions are based on the usage of the pipe and universal mounting brackets shown above.

Pipe Bracket Mounting

1. Mount a nominal 1/2 inch (21 mm) diameter pipe to the deck of the engine.
2. Install the pipe bracket to the LM300 using two 3/8-16 UNC x 1 inch bolts supplied. See Figure 1A.
3. Slip the LM300 onto the pipe and install the two adjustment bolts. Each adjustment bolt consists of a 3/8-16 UNC x 1 inch bolt and two nuts. See Figure 1B. **DO NOT** tighten the adjustment screws too tightly because you will have to adjust the LM300 later in the installation process.

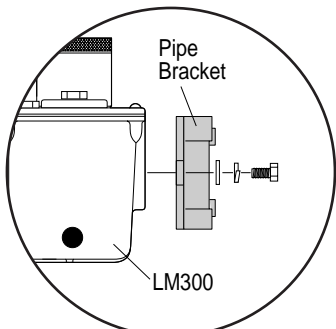

Figure 1A

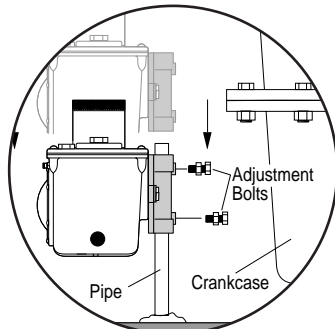

Figure 1B

Mounting with Universal Bracket

The universal bracket has two mounting methods: deck mounting and pan mounting.

Deck Mounting

1. Install the universal bracket to the deck as shown in Figure 2A with two flat washers and two 3/8 inch (10 mm) diameter bolts (not supplied).

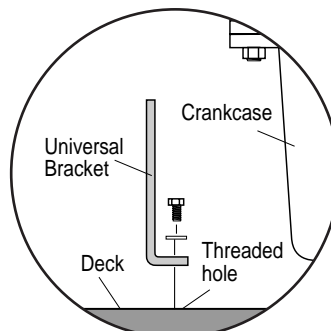

Figure 2A

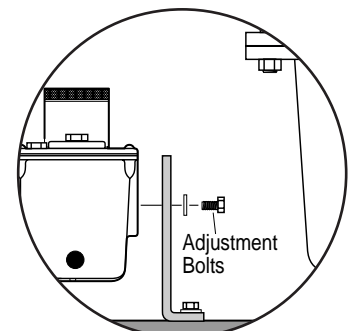

Figure 2B

2. Mount the LM300 to the universal bracket using two 3/8-16 UNC x 1 inch (25 mm) bolts supplied (Figure 2B). **DO NOT** tighten the adjustment screws too tightly. You will have to adjust the LM300 later in the installation process.

Crankcase (Oil Pan) Mounting

1. Install the universal bracket to the crankcase using the existing crankcase bolts (Figure 3A). Crankcase bolt diameter must be no larger than 7/16 inch (11 mm).

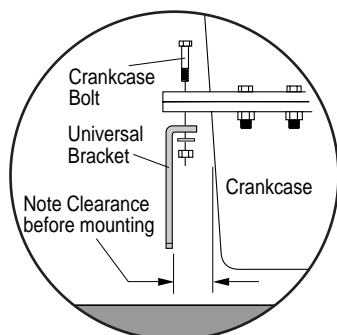

Figure 3A

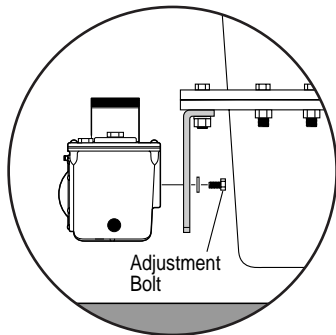

Figure 3B

NOTE: Check clearance between crankcase and mounting bracket before installing the mounting bracket. If space between the crankcase and mounting bracket does not allow installation and access to the adjustment bolts advance to Step 3.

2. Mount the LM300 to the universal bracket using two 3/8-16 UNC x 1 inch bolts supplied. **DO NOT** tighten the adjustment bolts too tight. You will have to adjust the LM300 later in the installation process.
3. If space between the crankcase and mounting bracket is narrow, install the universal mounting bracket to the LM300 before installing to the crankcase oil pan.

Connecting Fittings and Hoses

The following instructions are for all LM300 series level maintainers. All steps that reference oil inlet or oil supply tank **DO NOT** apply to non-level-maintaining models. Also, these instructions are based on the Murphy optional hose kit described on page 1. If you did not order the optional hose kit, gather the hoses, clamps and fittings as specified in the optional hose kit.

1. Install the LM300 fittings in their proper locations. **NOTE:** Apply a sealant such as teflon, to all threaded connections.
2. Attach the 1 inch (25 mm) diameter, flexible monitoring hose to the crankcase and the monitoring port on the LM300. See Figure 4. **CAUTION:** The hose must slope slightly downward from the LM300 and **MUST NOT** have any droop or low spots.

NOTE: If the drain plug on the crankcase is used for the connection, we recommend installation of a tee to allow draining of the crankcase for service.

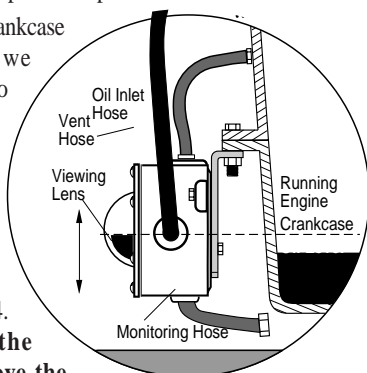

Figure 4

3. Install the 1/2 inch (13 mm) I.D. x 3 ft. (914 mm) hose to the vent connection on the LM300 to the vent connection on the crankcase. See Figure 4. **The vent connection on the crankcase must be well above the regulated oil level.** All hoses must be clear of obstructions.

BEFORE CONTINUING, VERIFY THAT ALL HOSE CLAMPS ARE TIGHT.

4. Fill the crankcase to the proper oil levels. With the engine running and warm, loosen the mounting bracket adjustment bolts and adjust the LM300 so that the oil level in the sight gauge is aligned with the white “index line” on the dial (Figure 4). Tighten the adjustment bolts securely.

Connecting the LM300 to an Oil Supply Tank (level maintaining models only)

1. Remove the caplug from the oil inlet connection. Be sure the filter, inside the connection, is clear of debris. Install the oil inlet connection.

2. Connect a 1/2 inch I.D. (13 mm) or larger hose to oil inlet fitting on the LM300 and to the shutoff valve on the oil supply tank. See Figure 5. For models LM300 thru LM305 recommended minimum mounting of the oil supply tank above the LM is 4 ft. (1.2m); maximum 15 ft. (4.6m). The hose must maintain a downward slope and not have low spots or droops. Maximum head pressure rating using standard 1/4 in. (6 mm) orifice is 15 ft. (4.6 meters). See Flow Rate test on page 1 for additional orifice pressure ratings.

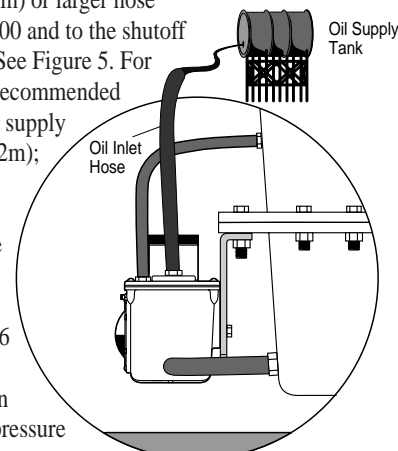

Figure 5

3. Before filling the supply tank with oil, be sure the tank is clean and dry and the shutoff valve is closed. Also, be sure all hoses and clamps are tight. Fill the tank with **CLEAN** oil.

WARNING: Overfill condition can be caused by excessive inlet pressure, (maximum inlet pressure depends on orifice), and/or improper “vent to crankcase” installation. See Flow Rate Test on page 1 for maximum pressure.

4. After oil supply tank is full, open the shutoff valve.

Next, make the proper electrical connections for the application. See contact ratings on page 1 and schematics on page 4.

Switch Test (switch models only)

To test the shutdown and/or alarm functions perform the following:

1. Unscrew protective boot from test knob. **IMPORTANT:** Always replace boot after testing.
2. Turn the test knob 1/4 turn to the right (clockwise), for low test indication (Figure 6).
3. Turn the knob 1/4 turn to the left (counterclockwise), for high test indication. **DO NOT FORCE THE TEST KNOB TO TURN.**

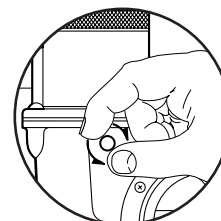

Figure 6

NOTE: After the engine shuts down, you will notice that the oil in the sight gauge glass will rise above normal running level, possibly showing an overfill condition. This is a result of “drain-back” to the engine crankcase and it is normal. Therefore, on models LM302 and LM303 it may be necessary to wire the high level shutdowns into a class “B” or “C” (bypass until first time safe) lockout, so as to allow a permissive start. After the engine is re-started the level will pull down to the normal running level and the shutdown features will be active. A modulating valve (Thumb-Valve™) in the level maintaining models will allow oil usage to be made-up continuously during operation.

SWITCH WIRING DIAGRAMS



WARNING: DISCONNECT ALL ELECTRICAL POWER BEFORE CONNECTING ANY WIRES.

LM301
SPDT

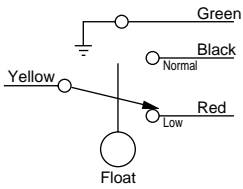

LM302
High/Low N.O.
DPST

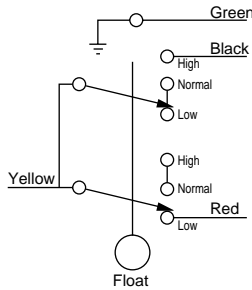

LM303
High/Low N.C.
DPST

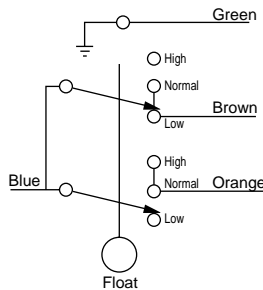

LM304
Alarm before
shutdown N.O.
DPST

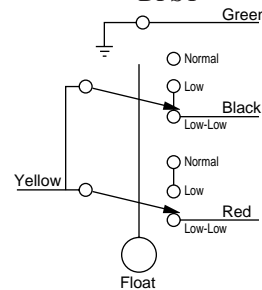

LM305
Alarm before
shutdown N.C.
DPST

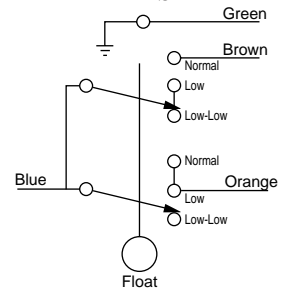

OPERATING RANGES OF SWITCHES

This section applies only to models that have built-in switches. The illustrations below and to the right show the dials and their operating ranges of the switches. If levels are within the designated zones the switch(es) will activate. **Notice** that a switch is capable of activating approximately 3/8 in. (10 mm) from the top of the high zone and 3/8 in. (10 mm) from the bottom of the low zone. The dial in **Figure 9** shows that if level continues to drop into the low-low zone, a shutdown will occur.

NOTE: Color zones on dial face show approximate normal operating zones. Actual conditions may vary depending upon operating characteristics of the engine. Placement of the LM300 according to the above instructions will compensate for these conditions.

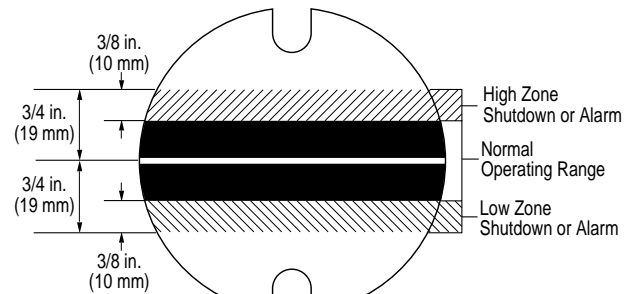

Figure 8: LM302/LM303

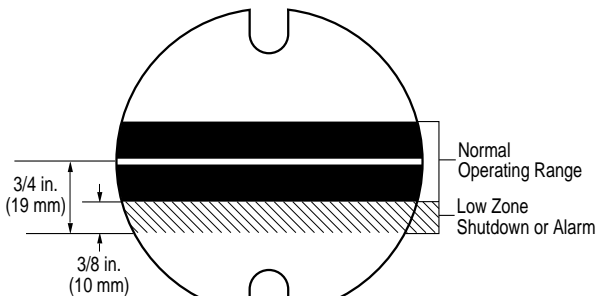

Figure 7: LM301

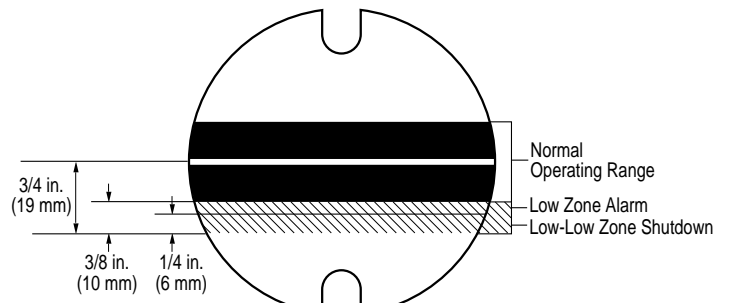

Figure 9: LM304/LM305

Warranty

A limited warranty on materials and workmanship is given with this FW Murphy product.
A copy of the warranty may be viewed or printed by going to www.fwmurphy.com/support/warranty.htm



FW Murphy
P.O. Box 470248
Tulsa, Oklahoma 74147 USA
+1 918 317 4100
fax +1 918 317 4266
e-mail sales@fwmurphy.com
www.fwmurphy.com

CONTROL SYSTEMS & SERVICES DIVISION
P.O. Box 1819; Rosenberg, Texas 77471; USA
+1 281 633 4500 fax +1 281 633 4588
e-mail sales@fwmurphy.com

MURPHY DE MEXICO, S.A. DE C.V.
Blvd. Antonio Rocha Cordero 300, Fracción del Aguaje
San Luis Potosí, S.L.P.; México 78384
+52 444 8206264 fax +52 444 8206336
Villahermosa Office +52 993 3162117
e-mail ventas@murphymex.com.mx
www.murphymex.com.mx

FRANK W. MURPHY, LTD.
Church Rd.; Laverstock, Salisbury SP1 1QZ; U.K.
+44 1722 410055 fax +44 1722 410088
e-mail sales@fwmurphy.co.uk
www.fwmurphy.co.uk

MURPHY SWITCH OF CALIFORNIA
41343 12th Street West
Palmdale, California 93551-1442; USA
+1 661 272 4700 fax +1 661 947 7570
e-mail sales@murphyswitch.com
www.murphyswitch.com

MACQUARRIE CORPORATION
1620 Hume Highway
Campbellfield, Vic 3061; Australia
+61 3 9358 5555 fax +61 3 9358 5558
e-mail murphy@macquarrie.com.au



In order to consistently bring you the highest quality, full featured products, we reserve the right to change our specifications and designs at any time.

Printed in U.S.A.