

# Installation for 4-1/2 in. (114 mm) dial Pressure Murphygage® and Swichgagage® instruments

Model Series: OPLC, OPLG, OPLBP, 45APE, 45APEBP, PT167EX and 45 Series  
 Options: -OS, -ES, -P4 and -P6



Please read the following instructions before installing. A visual inspection is recommended before mounting. General Information and these installation instructions are intended for all 4-1/2 in. (114 mm) dial pressure models.

## GENERAL INFORMATION

WARNING

BEFORE BEGINNING INSTALLATION OF THIS MURPHY PRODUCT

- ✓ Disconnect all electrical power to the machine.
- ✓ Make sure the machine cannot operate during installation.
- ✓ Follow all safety warnings of the machine manufacturer.
- ✓ Read and follow all installation instructions.

OPLC and OPLFC Swichgagage instruments have high and low limit contacts to monitor, alarm or shut down. The OPLC has a flanged case. A method to override the low limit contact for start-up is provided on most models. See Operation Test section—page 3.

OPLFC can be direct or panel mounted (see page 2).

OPLG and OPLFG Murphygage indication-only pressure instrument are similar to OPLC and OPLFC models, without switch (limit) contacts.

45 Series includes a magnetic switch to stop an engine or electric motor each time the gage contact operates. A lockout push button overrides low contact for startup. Other variations available.

45APE and 45APEF Series are versions of the OPLC Series featuring 2 snap-acting SPDT switches instead of the pointer type contacts. These units do not include low contact lockout.

OPLBP and 45APEBP are versions of the OPLC and 45APE featuring pilot duty limit switches connected to an internal latching control relay for “on/off” control directly or through a motor starter.

PT167EX The Murphy PT167EX is a pressure Swichgagage instrument connected to a threaded pressure diaphragm housing. The Swichgagage instrument is enclosed in an explosion-proof case and is CSA rated for Class I, Division 1, Groups C and D.

### Specifications

**Dial:** White on black, dual scale, psi/kPa standard, 4-1/2 in. (114 mm) diameter.

**Case:** Die cast aluminum, surface or panel mount.

**Process Connection:** 1/4 NPTM thru 1000 psi; 1/2 NPTM 1500 - 10,000 psi.



**Precautions:** Do NOT exceed rated pressure range. Dope or use teflon tape on connection threads. Do not block the inlet orifice. For direct mount into the process, a vertical or ninety degree mounting is recommended.

Use wrench on shank to tighten or loosen connection. Do not twist case when installing, this will damage internal components and will void the warranty. **Do not overtighten.**

Use shock mounts as necessary to prevent excessive vibration.

If liquid in the system freezes, it will expand and will damage the tube.

For 45APE Series – Low setpoint should be limited to the lower 1/2 scale and upper setpoint should be limited to the upper 1/2 scale.

**Sensing Element:** Bronze or 316 stainless steel bourdon tube.

**Gage Accuracy:**

All models and 45APE/45APEF between switch points:  
 ±2% for first and last quarters of scale; middle half of scale is ±1%.  
 Model 45APE/45APEF

Indicating Pointer above or below set point:

Range	Accuracy (±% F.S.) above and below s.p. only
<100 (except 15 psi)	10
15	15
100-300	4
400-1500	2
2000	12
3000-5000	8

Based on testing performed with switch point at mid scale which represents worst case.

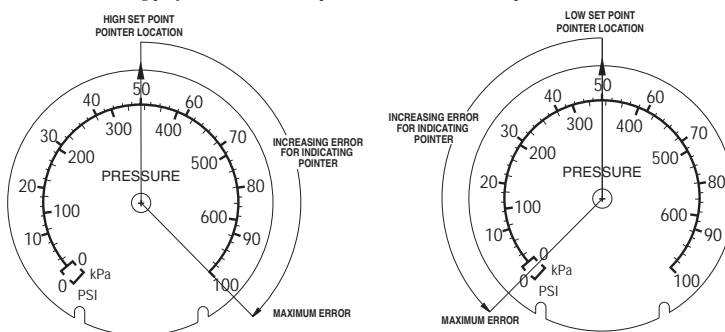

**Switch Point Accuracy:** ±1.5% (45APE/45APEF).

**Switch Reset Deadband:** Approximately 10% FS (45APE/45APEF).

**Snap-Acting Switches:** See wiring information (page 4) (45APE/45APEF).

**Overrange:** Do not exceed 10% FS above full range.

**Pressure Relief Disc:** Back of case (except EX models).

**Dry Relay Contact (“BP” Models):** 10 A @ 28 VDC or 10 A @ 120 VAC.

**Wire Connections (Surface Mount):** 1/2 NPTF conduit/ terminal block.

**Wire Connections (Panel Mount):** Wire leads, 18 AWG (1.0 mm<sup>2</sup>) x 9 in. (229 mm) long.

**Wire Connections (-ES, -OS):** 1/2 NPTM conduit and wire leads,

All except 45APEF:

18 AWG (1.0 mm<sup>2</sup>) x 33 in. (838 mm) long.

45APEF

24 AWG (0.22 mm<sup>2</sup>) x 33 in. (838 mm) long.

**Item Weight:** 5 lbs 6 oz (2.4 kg) approximately.

Explosion-proof models: 21 lb. (9.5 kg) approx.

**Item Dimensions:** 10 x 9 x 6 in. (254 x 229 x 152 mm) approximately.

Explosion-proof models: 12 x 12 x 9 in. (305 x 305 x 229 mm) approximately.

### Warranty

A limited warranty on materials and workmanship is given with this FW Murphy product. A copy of the warranty may be viewed or printed by going to [www.fwmurphy.com/support/warranty.htm](http://www.fwmurphy.com/support/warranty.htm).

\*Selected configurations are third party listed. Consult factory for details.

## OPL Series Wall Mount

Flanged case design intended for wall mount, it can also be direct mounted. Shown with shock mounts and pulsation dampener.

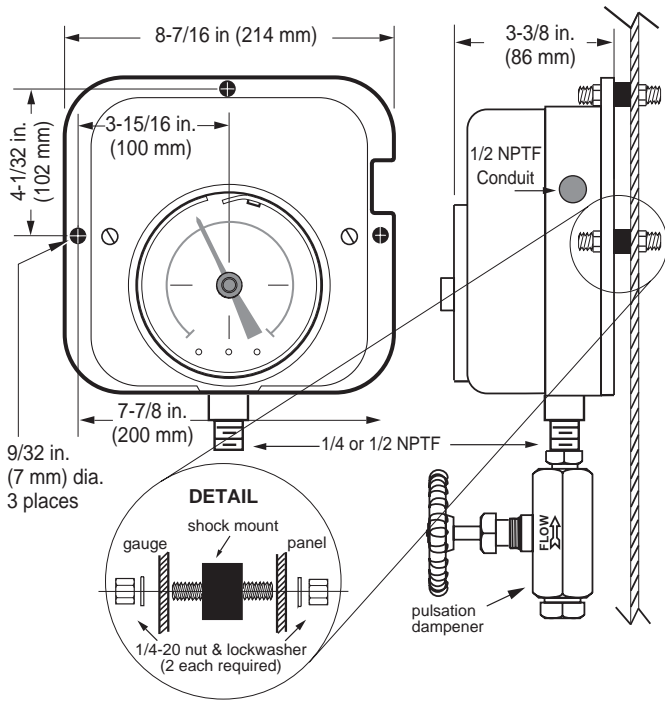

## 45APE Series Wall Mount

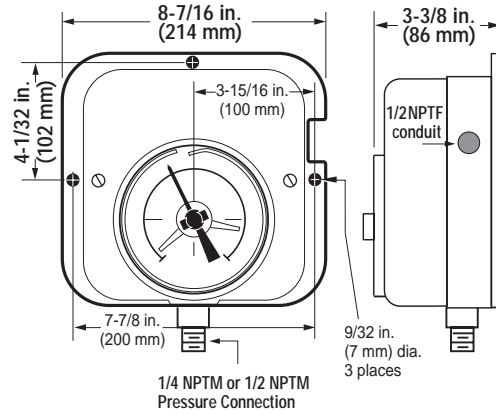

## 45APE Series Flush Mount

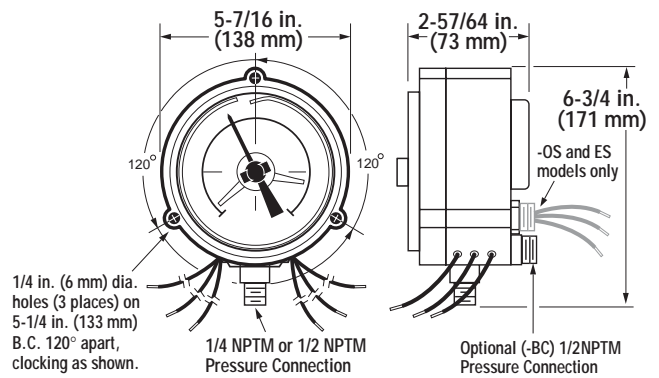

## OPL Series Flush Mount

Round case design to be mounted in a panel from 1/32 in. (1 mm) to 1/8 in. (3 mm) thick. It can also be direct mounted. Shown with pulsation dampener.

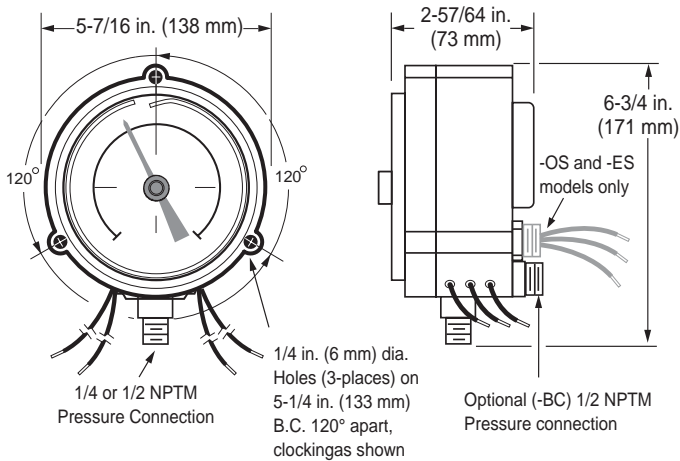

## Options "OS" and "ES" (flush mount case)

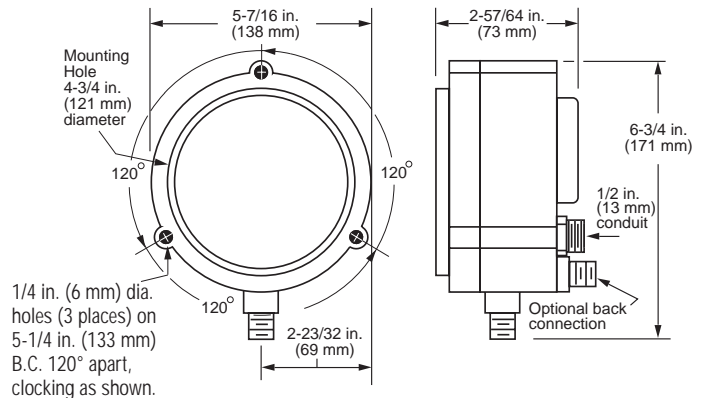

## Explosion-proof Case Mount Explosion-proof case can be mounted from face or rear.

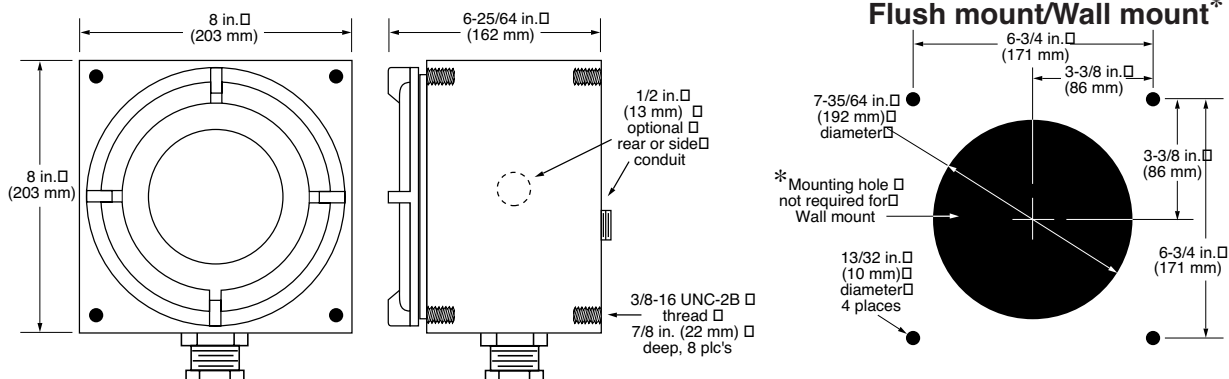

## OPTIONS

-OS and -ES (oil sealed and environment sealed case) for corrosive environment, feature a panel mount case or screw directly into the process. See Case Mounting (p-2).

-P6 Sealed mechanism with a typical application for oil well lead lines. Its 2 NPT housing and diaphragm seal filled with silicon fluid attaches directly into a 2 NPT tee on the lead line. Tighten only the 2-5/8 in. (67 mm) hex fitting.

**CAUTION: Do not tamper with or break sealed connections.**

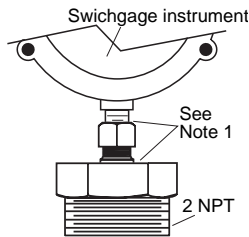

-P4L is a remote seal mechanism with stainless steel armored capillary to protect the gage from highly viscous and/or corrosive fluids.

1. Loosen the eight housing bolts until the bottom housing is free to turn.

**CAUTION: Do Not unscrew the green diaphragm capsule.**

2. Tighten the bottom housing to the pressure source.
3. Tighten the eight housing bolts to  $25 \pm 3$  foot lbs. by staggering the tightening for even clamping.
4. Route capillary away from heat source such as exhaust manifold. Excess capillary should be carefully coiled and secured to avoid damage.

**CAUTION: Do Not cut capillary or make sharp bends.**

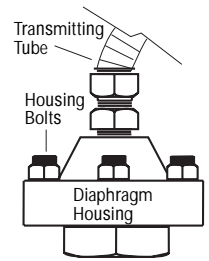

## ADJUSTMENTS

### OPL/45 Series Limit Contact Adjustments

Facing the dial, left side knob is the "Low limit" contact and the "High limit" contact is located to the right. To set the limit contacts simply turn the fingertip type knob to the desired point on the scale.

### 45APE Series Trip Point Adjustments

The 45APE Series features a stacked limit indicator adjustments knob. The bottom half knob adjusts the "Low" limit indicator, the top half is to adjust the "High" limit indicator. To set the limit contacts simply turn the fingertip type knob to the desired point on the scale.

### OPL and 45 Series Indicating Pointer Adjustments

To reset to zero or to a known value do as follows:

1. Turn off electrical power. Remove the snap ring and very carefully remove the lens and contact assembly (or open hinged cover).
2. Hold the pointer hub with thumb and forefinger then turn screw to desired point. See **DETAIL "A"**.
3. Replace lens and contact assembly and snap ring (or close hinged cover), and turn on the power.

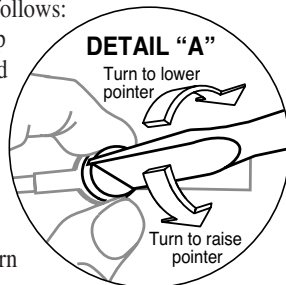

### 45APE Series Pointer Adjustments

To reset to zero or to a known value proceed as follows:

1. Turn off electrical power. Remove the snap ring and very carefully remove the lens and contact assembly (or open hinged cover).
2. Hold the the Switch Operator and the pointer hub with thumb and forefinger, then turn the Pointer Adjustment screw to the desired point. See **DETAIL "B"**.
3. If the Switch Operator needs adjustment, hold the Switch Operator and the pointer hub with thumb and forefingers as show on **DETAIL "C"**, and turn the adjustment screw until the Switch Operator aligns with the indicating pointer.
4. Replace the lens and contact assembly and the snap ring (or close hinged cover). Turn the power back on.

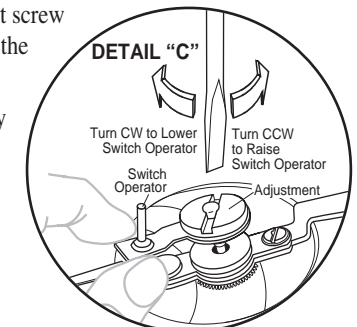
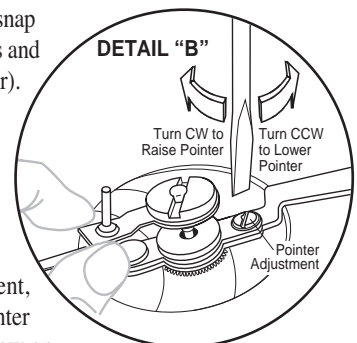

## OPERATION TEST INSTRUCTIONS

### OPLC, OPLFC and OPLBP

1. Perform operation test after the unit is installed and wired appropriately. (See the typical wiring diagram, on page 4.)
2. When pressure is applied to the instrument, the pointer will travel in a clockwise direction. Adjust the limit contacts to the desired settings.
3. To start, place the toggle switch in the "start" position or otherwise override low contact.
4. After the indication pointer rises above the low limit contact, return the toggle switch or override device to the "run" position.
5. To test the limit contacts, turn the limit contact to be tested until it touches the pointer. That will trip the control circuit.
6. Reset the shutdown or alarm circuit device and repeat above sequence for each contact/trip point.

### 45 Series

1. Repeat steps 1 and 2. (See OPLC operation test instructions.)
2. Press the semi-automatic pushbutton located on the low contact knob.
3. Reset the magnetic switch pushbutton.
4. After the indication pointer rises above the low limit contact, the lockout - pushbutton automatically disengages and the low limit is armed.
5. Repeat steps 5 and 6. (See OPLC operation test instructions.)

### 45APE, 45APEF and 45APEBP

1. Repeat steps 1 and 2. (See OPLC operation test instructions.)
2. To test the switches, turn the trip point indicator until it is aligned with the Swichgage pointer. This is the approximate trip point. Continue to rotate until the snap switch operates.
3. Reset the shutdown or alarm circuit device.

# TYPICAL ELECTRICAL DIAGRAMS



**WARNING:** PERFORM THE WIRING OPERATION WITH THE POWER SOURCE "OFF". MAKE SURE THE VOLTAGE AND CURRENT REQUIREMENTS ARE WITHIN THE SWITCHGAGE RATINGS. BEFORE WIRING DETERMINE VOLTAGE AND POLARITY FOR THE APPLICATION. USE THE APPROPRIATE WIRE SIZE. ALL CONNECTIONS SHOULD BE MADE USING A SPADE (FORKED) OR RING TERMINALS. FOR PIGTAIL CONNECTIONS USE WIRE NUTS. CONDUIT IS RECOMMENDED TO PROTECT WIRES FROM DAMAGE.

## OPLC and OPLFC

**Contact Rating:** 1 SPDT, Center Off; 2 A, 30 VDC, 1 A, 125 VAC pilot duty.

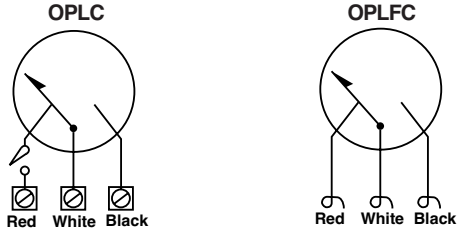

**NOTE:** Diagrams above show the Switchgauge pointer in the at rest (shelf) position.

## 45APE and 45APEF

**Contact Rating:** 2-SPDT snap-switches (one for high and low pressure), 2 A inductive, 250 VAC each switch. **NOTE:** Diagram below shows the Switchgauge pointer in the at rest (shelf) position. Low setpoint should be limited to the lower 1/2 scale and upper setpoint should be limited to the upper 1/2 scale.

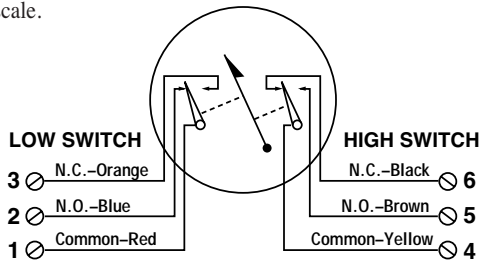

## 45 Series with MS2100

Models available for Battery ignition, CD ignition, Magneto or 110VAC systems. **Contact Rating:** 12/32 VDC coil, 10 A, 32 VDC battery ignition contacts; Magneto ignition coil, 10 A magneto ignitions contacts; CD ignition coil, 10 A CD ignition contacts; 120 VAC coil, 10 A, 120 VAC contacts.

**NOTE:** The diagram at right shows the Switchgauge pointer in the operating position.

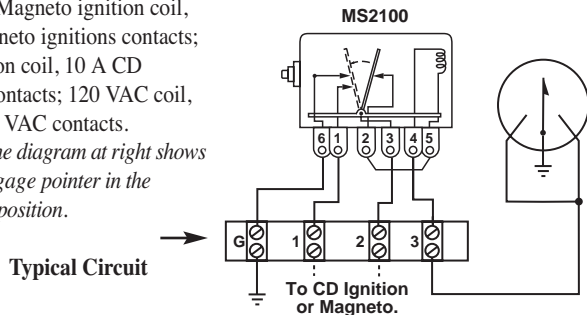

## OPLBP

**Contact Rating:** SPDT dry relay contacts; 10 A, 125 VAC. **NOTE:** Diagram below shows the Switchgauge pointer in the at rest (shelf) position.

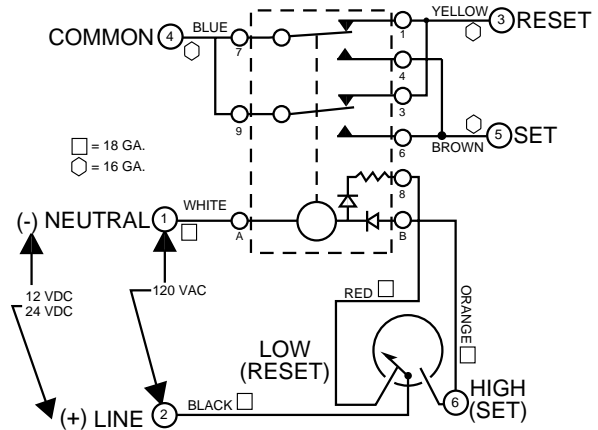

## 45APEBP

**Contact Rating:** SPDT dry relay contacts; 10 A, 125 VAC. **NOTE:** Diagram below shows the Switchgauge pointer in the at rest (shelf) position.

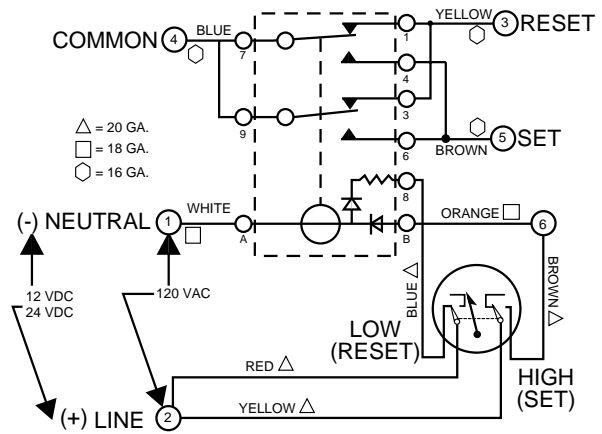

## Transformer Relay Assemblies

For higher voltages, Murphy TR Assemblies can be used in conjunction with any Switchgauge instrument.

**MURPHY**  
www.fwmurphy.com

918.317.4100 Email: sales@fwmurphy.com

MURPHY, the Murphy logo, Murphygauge® and Switchgauge® are registered and/or common law trademarks of Murphy Industries, Inc. This document, including textual matter and illustrations, is copyright protected by Murphy Industries, Inc., with all rights reserved. (c) 2006 Murphy Industries, Inc. Other third party product or trade names referenced herein are the property of their respective owners and are used for identification purposes only.